

# AIR-020X

## AI Inference System Based on NVIDIA® Jetson™ Xavier NX



### Features

- Extreme Compact and performance AI box up to 21 TOPS AI computing
- NVIDIA® Jetson™ Xavier NX built-in
- 12-24V wide power and -10-55 °C wide temp. supported
- Multiple IO ports: Dual LAN, DIO, 2x COM, 2x USB 3.2 and USB type C
- M.2 2280 128GB storage built-in
- Edge AI Suite AI Utility Support for pre-trained models and deep learning
- Linux Ubuntu 18.04 LTS and JetPack 4.5.1 preload
- IP40 Design compliance
- Qualified for Edge AI SRP of WISE-DeviceOn



### Specifications

Processor System	CPU	ARM v8.2 Six core Carmel processors, Max. 1.9 GHz
	GPU	Volta 384 CUDA core and 48 Tensor cores
	AI Performance Reference	21 TOPS (INT8)
	Memory	8 GB LPDDR4
	Flash	16G eMMC
Ethernet	Interface	RJ-45
	Controller	Intel® i210AT, Nvidia SoM
	Speed	2 x Gigabit Ethernet (10/100/1000 Mbps)
Display	HDMI	1 x HDMI (Max. resolution 3840 x 2160 @ 60Hz)
IO Ports	USB	2 x USB 3.2 Type A 1 x USB 3.2 Type C
	OTG USB	1 x Micro USB (for system recovery only)
	CANBus	1 x DB9
	DI/DO	8 bit
	COM	2 x RS-232/RS-422/RS-485
Expansion	MiniPCle	1 x Full-size mPCIE with Nano SIM slot (USB/PCle signal)
Storage	M.2 2280	1 x M.2 2280 (M Key), 128GB storage built-in
Power	Power Supply	Power adaptor 65W, optional
	Power Type	ATX/AT mode, ATX default
Environment	Operational Temperature	-10 ~ 55 °C with 0.7 m/s air flow (non-throttling)
	Operating Humidity	95% @ 40 °C (non-condensing)
	Vibration	3 Grms @ 5 ~ 500 Hz, random, 1 hr/axis
Mechanical	Dimensions (W x D x H)	138 x 110 x 43.6 mm
	Weight	0.85 kg
	Mounting Support	Wall mounting
Operating System	Linux	Ubuntu 18.04 LTS with JetPack 4.5.1
Software Support	Software API	Edge AI Suite/FaceView compatible
Certifications	EMC/Safety	CE/FCC Class B, CB, UL, CCC and BSMI (No RED Certificate)

## Dimensions

Unit: mm

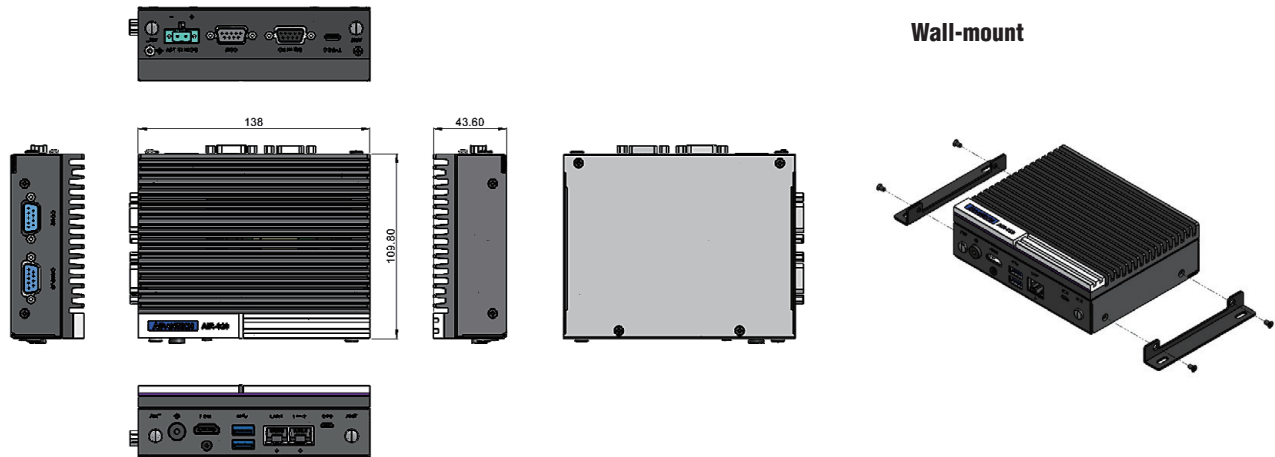

## Front Panel I/O Mechanical Layout

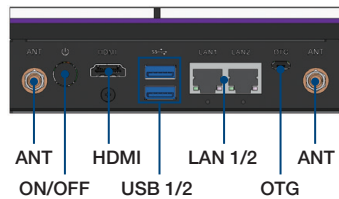

## Rear Panel I/O Mechanical Layout

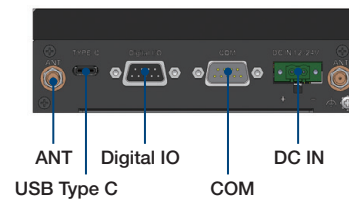

## Side Panel I/O Mechanical Layout

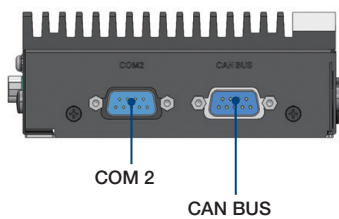

## Ordering Information

Part No.	CPU	VPU	Memory	Storage	HDMI	GbE	USB	CANBus	RS-232/422/485	DIO	Power input	Operating Temperature
AIR-020X-S9A1	ARM v8.2, six cores	Volta 384 CUDA core and 48 Tensor cores	8GB LPDDR4 built-in	16GB eMMC onboard, 128GB M.2 built-in	1	2	3	1	2	1	12-24V <sub>DC</sub>	-10-55 °C

## Packing List

Part Number	Description	Quantity
AIR-020X-S9A1	NVIDIA AI Inference System	1
1700028866-01	Micro USB cable 40cm for system recovery	1
-	Simplified Chinese User Manual	1

## Optional

Part Number	Description
96PSA-A65W19P2-1	Power adapter 19V 65W
1700001524	Power Cord UL 3P 10A 125V 183cm (US)
170203183C	Power Cord EU 3P 2.5A 250V 183cm (EU)
170203180A	Power Cord BSI 3P 2.5A 250V 183cm (UK)
1702031836	Power Cord SAA 3P 10A 250V 183cm (AU)
1700008921	Power Cord PSE 3P 7A 125V 183cm (Japan)
1700019146	Power Cord CCC 3P 2.5A 250V 183cm (China)
AMK-W005	Wall mount kit

# WISE-DeviceOn

## Edge AI OTA and Container Management

### WISE-DeviceOn End-to-End Solution for Edge AI

Even if all datasets, algorithms, trainings, UI/UX, and more are functioning, how can you easily deploy an AI application to hundreds, or thousands, of inference devices in production? How can you efficiently manage AI models (software updates, CI/CD), in addition to all remote, hardware devices, such as sensors?



### Solution Advantages



#### Performance Booster

- Inference optimization
- Open Neural Network Compiler (ONNC)
- Save over 45% DRAM consumption



#### Fleet Management

- Remote batch control for power management, reboot, terminal and screenshot
- Real-time monitoring, diagnostics and notification
- Over 10,000 devices around the globe



#### Container and OTA

- Streamlined deployment process
- Docker container management
- Software OTA (over-the-air) updates



#### AI Security

- AI containers deployed via Azure Container Registry and Harbor
- Secured data connection (TLS/SSL)
- Integrity protection based on digital signature

👉 Find More Information about [WISE-DeviceOn End-to-End Solution for Edge AI](#)