

AIR-075

Edge AI Inference system powered by NVIDIA Jetson Thor



Features

- Powered by NVIDIA Jetson T5000™ and Jetson T4000™, delivering up to 2070 TFLOPS FP4 inference performance.
- 19–36V wide power and -10–40 °C wide temp. supported
- Multiple I/O Expansion: 2x USB-C 3.2 Gen 2, 2x USB-A 3.2 Gen 1, 1x M.2 B Key (5G/LTE), and 2x M.2 E Key (NVMe / Wi-Fi).
- Supports 10GbE with Base-T connectors.
- Support Edge AI SDK / Inference Kit / WEDA.



Specifications

Processor Module	Module	NVIDIA Jetson T5000	NVIDIA Jetson T4000
	CPU	14-core Arm® Neoverse®-V3AE 64-bit CPU	12-core Arm® Neoverse®-V3AE 64-bit CPU
	GPU	2560-core NVIDIA Blackwell architecture GPU with 96 fifth-gen Tensor Cores	1536-core NVIDIA Blackwell architecture GPU with 64 fifth-gen Tensor Cores
	AI Performance	2070 TFLOPS (FP4—Sparse)	1200 TFLOPS (FP4—Sparse)
	Memory	128GB 256-bit LPDDR5X , 273 GB/s	64GB 256-bit LPDDR5X , 273 GB/s
Ethernet	Interface	RJ-45 optional PoE support (IEEE 802.3 af)	
	PHY	Marvell AQR113	
	Speed	4x 10GbE Ethernet (10M/100M/1G/2.5G/10Gbps)	2x 10GbE Ethernet (10M/100M/1G/2.5G/10Gbps)
Display	HDMI	1x HDMI 2.1, Max 3840 x 2160 (4K) at 60 Hz	
	DP	1x DP 1.4a, 3840 x 2160(4K) at 60 Hz	
IO Ports	USB	2x USB 3.2 Gen1 Type C (USB 5 Gbps / DP1.4a) 2x USB 3.2 Gen2 Type A (USB 10 Gbps) 1x USB USB 3.2 Gen1 Type C (RCM only)	
	CANBus	2x DB9	N/A
	DI/DO	1x DB9(8 bit)	
	COM	2x RS-232/RS-422/RS-485	
	Audio	Line-out, Mic-in	
Expansion	M.2	1x M.2 3052 B Key(5G/LTE) / 1x M.2 2230 E Key (WIFI/BT)	
Others	TPM	TPM2.0 (Optional)	
Storage	M.2	1 x M.2 2280 M Key (NVME) /1x M.2 2242 M Key (NVME)	
Power	Power Input	19–36V DC input	
	Power Type	ATX/AT mode, ATX default	
Environment	Op.Temp	-15 ~ 40°C (non-POE) / -15 ~ 35°C (POE) with 0.7 m/s air flow	-15 ~ 50°C (non-POE) / -15 ~ 40°C (POE) with 0.7 m/s air flow
	Op. Humidity	95% @ 40 °C (non-condensing)	
	Vibration	3 Grms @ 5 ~ 500 Hz, random, 1 hr/axis	
Mechanical	Dimensions (W x D x H)	235.8 x 174 x 59 mm	
	Weight	2.89Kg	
	Mounting Support	Wall mounting	
Operating System		Ubuntu 24.04 LTS with NVIDIA Jetpack™ 7.1	
Software Support	Software API	Edge AI SDK compatible	
Certifications	EMC/Safety	CE/FCC Class B, CB, UL, CCC and BSMI (No RED Certificate)	

Advantech SUSI is a device management and system monitoring suite for hardware configuration, control, and status monitoring.
SUSI information: <https://github.com/ADVANTECH-Corp/SUSI>

Dimensions

Unit: mm

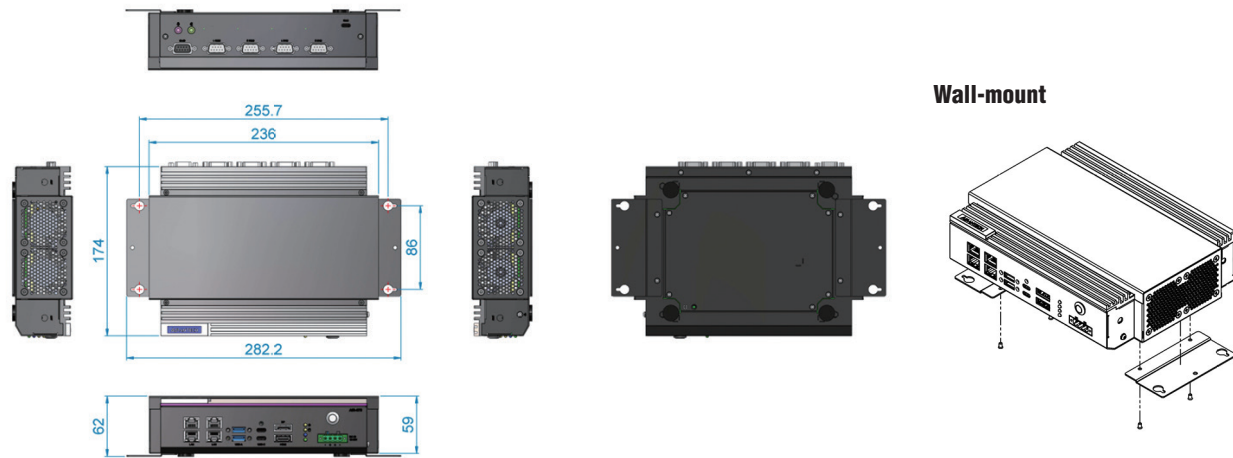

Front Panel I/O Placement

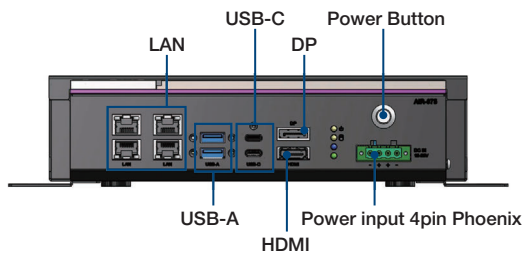

Back Panel I/O Placement

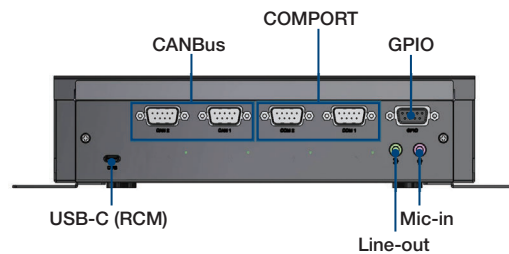

Ordering Information

Part No.	Module	CPU	GPU	AI Performance	Memory	Storage	10GbE	HDMI	DP	USB	CANBus	DIO	RS-232/422/485	DIO	Power Input	Operating Temperature
AIR-075A-S6A1U	NVIDIA Jetson T5000	14-core Arm® Neoverse®-V3AE 64-bit CPU	2560 NVIDIA Blackwell cores and 96 Cores	2070 TFLOPS (FP4—Sparse)	128GB	512GB	4	1	1	4	2	8 bit	2	8 bit	19-36V _{DC}	-10-40°C
AIR-075A-S6B1U	NVIDIA Jetson T4000	12-core Arm® Neoverse®-V3AE 64-bit CPU	1536 NVIDIA Blackwell cores and 64 Tensor Cores	1200 TFLOPS (FP4—Sparse)	64GB	512GB	2	1	1	4	NA	8 bit	2	8 bit	19-36V _{DC}	-10-50°C

Packing List

Part Number	Description	Quantity
AIR-075	NVIDIA AI Inference System	1
1700036172-01	Type C cable for system recovery	1
-	Wall Mount Kit for AIR-075	2
-	User Manual	1

Optional

Part Number	Description
96PSA-A330W24P4-3	A/D 100-240V 330W 24V C14 TERMINAL BLOCK 4P
1702002600	Power Cord UL 3P 10A 125V 183cm (US)
1702002605	Power Cord EU 3P 10A 250V 183cm (EU)
1702031801	Power Cord BSI 3P 10A 250V 183cm (UK)
1700000237	Power Cord PSE 3P 12A 125V 183cm (Japan)
1700013977	Power Cord CCC 3P 10A 250V 200cm 90°(China)
AIW-169BR-GX1	Wi-Fi 6E M.2 E-Key
AIW-356DQ-JK1	5G M.2 3052 B-Key
MIOE-PSE-DPA1	MIOe-PSE PoE Module A1 dual 15.4W w/ Heatsink

Inference Kit | Production-Ready AI Inference on Edge Devices

Provides a unified and hardware-aligned runtime for deploying and validating AI inference on edge devices

It simplifies integration across CPUs, GPUs, and AI accelerators while enabling performance benchmarking and compatibility verification on target hardware. Designed for production use, Inference Kit helps hardware partners ensure stable, scalable, and repeatable AI deployment across product lines.

Edge AI SDK Inference Kit

Streamlined Edge Inference

- Ready-to-Run Inference Runtime
- Accelerator-Aware Optimization
- Stable Edge Production Stack
- Unified Inference Interfaces

Benefits and Features



Unified Inference Runtime

- Consistent inference across CPUs, GPUs, and accelerators
- Vendor-optimized runtime integration
- Built-in UniInfra acceleration framework
- Optimized inference pipelines and runtime efficiency



Hardware Validation

- Benchmarking on target devices
- OS and accelerator compatibility validation
- Performance and stability verification



Production-Ready Deployment

- Stable, long-running inference operation
- System monitoring and observability support
- Designed for scalable edge deployment



Global Customer Support

- System reliability certification
- Inference computing enablement
- Edge-to-cloud scalability collaboration

