

Neousys Technology Inc.

GT-92 Series

User Manual

Revision 1.3

Table of Contents

Table of Contents	2
Legal Information	5
Contact Information	6
Declaration of Conformity	6
Copyright Notice	7
Safety Precautions.....	8
Service and Maintenance	10
Avertissement concernant les piles	10
Hot Surface Warning.....	11
Surface chaude	11
Battery Warning.....	12
Entretien et eparation	12
ESD Precautions	13
Précautions nécessaires de décharge électrostatique (ESD)	13
Restricted Access Location	14
Lieu d'accès restreint	14
About This Manual	15

1 Introduction

1.1 Product Specifications.....	17
1.1.1 GT-92GC Specifications.....	17
1.1.2 GT-92RL-H Specification	20
1.2 GT-92 Series Dimension	22
1.2.1 GT-92 Series Front Panel View.....	22
1.2.2 GT-92 Series Rear Panel View	22
1.2.3 GT-92 Series Top View	23
1.2.4 GT-92 Series Bottom View.....	23
1.3 GT-92 Series Dimensions with Rack Mount Bracket.....	24
1.3.1 GT-92 Series Front View with Rack Mount Bracket	24
1.3.2 GT-92 Series Side View with Rack Mount Bracket	24
1.4 GT-92 Series Dimensions with Wall Mount Bracket	25
1.4.1 GT-92 Series Front View with Wall Mount Bracket.....	25
1.4.2 GT-92 Series Side View with Wall Mount Bracket.....	25

2 System Overview

2.1 Packing List	26
2.1.1 GT-92 Series Packing List	26
2.2 Front Panel I/O.....	27
2.2.1 2.5" HDD Tray.....	29
2.2.2 4-pole 3.5mm Headphone/ Microphone Jack.....	29
2.2.3 Grounding Point	30
2.2.4 HDMI Port	31
2.2.5 DisplayPort	32
2.2.6 USB3.2 Gen2x1 Port	33
2.2.7 CAN Port 1/ 2.....	34
2.2.8 Digital Input/ Output	35
2.2.9 COM 1/ 2 Port.....	38
2.2.10 M12 X-coded Gigabit Ethernet Port 1	39
2.2.11 M12 X-coded Gigabit Power Over Ethernet Ports (2-9).....	40
2.2.12 System Status LED	41
2.2.13 Clear CMOS Button	41
2.2.14 Reset Button	42
2.2.15 Power Button	42
2.2.16 M12 L-coded DC Input (GT-92GC).....	43
2.2.17 M12 K-coded DC Input (GT-92RL-H).....	44
2.3 Internal I/O Functions.....	45
2.3.1 Mini-PCIe Socket & Pin Definition.....	45

2.3.2	M.2 2280 (M Key) Slot for NVMe SSD	47
2.3.3	Ignition Power Control Switch	49

3 System Installation

3.1	Removing the Bottom Panel.....	51
3.2	Grounding Procedure	53
3.3	Installing Internal Components	54
3.3.1	Mini-PCIe Module and Micro-SIM (3FF) Card Installation.....	54
3.3.2	M.2 2280 NVMe SSD Installation.....	57
3.4	Installing the Bottom panel.....	60
3.5	2.5" SATA HDD/ SSD Installation.....	61
3.6	Wall-mount Bracket Installation	62
3.6.1	Wall-mount Bracket Installation.....	62
3.6.2	Rack-mount Bracket Installation	63
3.7	Powering On the System	64
3.7.1	Powering On Using the Power Button.....	64
3.7.2	Powering On Using Wake-on-LAN.....	65
3.8	Ignition Power Control (GT-92GC Only)	67
3.8.1	Principles of Ignition Power Control	67
3.8.2	Additional Features of Ignition Power Control	68
3.8.3	Wiring Ignition Signal (GT-92GC Only)	69
3.8.4	Configure your Windows system.....	70
3.8.5	Operation Modes of Ignition Power Control	71

4 System Configuration

4.1	BIOS Settings	73
4.1.1	COM Port Configuration.....	74
4.1.2	COM Port High Speed Mode	75
4.1.3	CAN Termination.....	76
4.1.4	CPU PCI Express Configuration	77
4.1.5	Volume Management Device (VMD).....	78
4.1.6	TPM Availability.....	80
4.1.7	Power over Ethernet (PoE) Power Enable	81
4.1.8	Auto Wake on S5	83
4.1.9	Power On After Power Failure Option	84
4.1.10	Power & Performance (CPU SKU Power Configuration)	85
4.1.11	Wake on LAN Option	86
4.1.12	Boot Menu	87
4.1.13	Add Boot Options (Position New Boot Device)	89
4.1.14	Watchdog Timer for Booting.....	90
4.2	AMT Configuration	91
4.3	RAID Configuration	93
4.3.1	Enabling Volume Management Device (VMD) for RAID Volume Setup	93
4.3.2	RAID Volume Setup	94
4.3.3	Loading RAID Driver for Windows Installation	101

5 OS Support and Driver Installation

5.1	Operating System Compatibility	104
5.2	System Driver Installation.....	105
5.3	Driver Installation for Watchdog Timer Control	105

Appendix A Using WDT & DIO

WDT and DIO Library Installation	107
WDT Functions.....	109
InitWDT	109
SetWDT	109
StartWDT.....	110
ResetWDT.....	110

StopWDT..... 110

Appendix B PoE On/ Off Control

GetStatusPoEPort 111
EnablePoEPort 112
DisablePoEPort 113

Legal Information

All Neosys Technology Inc. products shall be subject to the latest Standard Warranty Policy

Neosys Technology Inc. may modify, update or upgrade the software, firmware or any accompanying user documentation without any prior notice. Neosys Technology Inc. will provide access to these new software, firmware or documentation releases from download sections of our website or through our service partners.

Before installing any software, applications or components provided by a third party, customer should ensure that they are compatible and interoperable with Neosys Technology Inc. product by checking in advance with Neosys Technology Inc.. Customer is solely responsible for ensuring the compatibility and interoperability of the third party's products. Customer is further solely responsible for ensuring its systems, software, and data are adequately backed up as a precaution against possible failures, alternation, or loss.

For questions in regards to hardware/ software compatibility, customers should contact Neosys Technology Inc. sales representative or technical support.

To the extent permitted by applicable laws, Neosys Technology Inc. shall NOT be responsible for any interoperability or compatibility issues that may arise when (1) products, software, or options not certified and supported; (2) configurations not certified and supported are used; (3) parts intended for one system is installed in another system of different make or model.

Contact Information

For contact information, please visit our [official website](#)

Declaration of Conformity

FCC

This equipment has been tested and found to comply with the limits for a Class A digital device, pursuant to part 15 of the FCC Rules. These limits are designed to provide reasonable protection against harmful interference when the equipment is operated in a commercial environment. This equipment generates, uses, and can radiate radio frequency energy and, if not installed and used in accordance with the instruction manual, may cause harmful interference to radio communications. Operation of this equipment in a residential area is likely to cause harmful interference in which case the user will be required to correct the interference at own expense.

CE

The product(s) described in this manual complies with all applicable European Union (CE) directives if it has a CE marking. For computer systems to remain CE compliant, only CE-compliant parts may be used. Maintaining CE compliance also requires proper cable and cabling techniques.

Copyright Notice

All rights reserved. This publication may not be reproduced, transmitted, transcribed, stored in a retrieval system, or translated into any language or computer language, in any form or by any means, electronic, mechanical, magnetic, optical, chemical, manual or otherwise, without the prior written consent of Neosys Technology, Inc.

Disclaimer

This manual is intended to be used as an informative guide only and is subject to change without prior notice. It does not represent commitment from Neosys Technology Inc. Neosys Technology Inc. shall not be liable for any direct, indirect, special, incidental, or consequential damages arising from the use of the product or documentation, nor for any infringement on third party rights.

Patents and Trademarks

Neosys, the Neosys logo, Expansion Cassette, MezIO™ are registered patents and trademarks of Neosys Technology, Inc.

Windows is a registered trademark of Microsoft Corporation.

Intel®, Core™ are registered trademarks of Intel Corporation

NVIDIA® is a registered trademark of NVIDIA Corporation

All other names, brands, products or services are trademarks or registered trademarks of their respective owners.

Safety Precautions

- Read these instructions carefully before you install, operate, or transport the system.
- Install the system or DIN rail associated with, at a sturdy location
- Install the power socket outlet near the system where it is easily accessible
- Secure each system module(s) using its retaining screws
- Place power cords and other connection cables away from foot traffic. Do not place items over power cords and make sure they do not rest against data cables
- Shutdown, disconnect all cables from the system and ground yourself before touching internal modules
- Ensure that the correct power range is being used before powering the device
- Should a module fail, arrange for a replacement as soon as possible to minimize down-time
- By means of a power cord connected to a socket-outlet with earthing connection
- If the system is not going to be used for a long time, disconnect it from mains (power socket) to avoid transient over-voltage

Mesures de sécurité

- Lire attentivement ces directives avant d'installer, d'utiliser ou de transporter le système.
- Installer le système ou la barrette DIN qui lui est associée, à un endroit solide
- Installer la prise de courant près du système et pour qu'elle soit facilement accessible
- Fixer chaque module du système à l'aide de ses vis de fixation
- Éloigner de la circulation piétonne les cordons d'alimentation et autres câbles de connexion. Ne jamais placer d'objets sur les cordons d'alimentation et s'assurer qu'ils ne reposent pas contre les câbles de données
- Avant de toucher les modules internes, arrêter, débrancher tous les câbles du système et raccordez-vous à la terre
- S'assurer que la bonne plage de puissance est utilisée avant d'alimenter l'appareil
- Prévoir un remplacement dès que possible en cas de défaillance d'un module, afin de minimiser les temps d'arrêt
- Au moyen d'un cordon d'alimentation branché à une prise de courant avec mise à la terre (MALT)
- Si le système ne sera pas être utilisé pendant une période prolongée, le débrancher du réseau (prise de courant) pour éviter une surtension transitoire

Service and Maintenance

- ONLY qualified personnel should service the system
- Shutdown the system, disconnect the power cord and all other connections before servicing the system
- When replacing/ installing additional components (expansion card, memory module, etc.), insert them as gently as possible while assuring proper connector engagement

Avertissement concernant les piles

- Les piles risquent d'exploser si elles sont mal installées.
- Ne jamais essayer de recharger, d'ouvrir de force ou de chauffer les piles.
- Remplacer les piles uniquement avec le même type ou l'équivalent recommandé par le fabricant.

Hot Surface Warning



HOT SURFACE. DO NOT

TOUCH. "ATTENTION: Surface chaude. Ne pas toucher."

WARNING!

Components/ parts inside the equipment may be hot to touch!

Please wait one-half hour after switching off before handling parts.

Surface chaude

AVERTISSEMENT : *SURFACE CHAUDE. NE PAS TOUCHER.*

Les composants et pièces à l'intérieur de l'équipement peuvent être chauds au toucher. Après l'arrêt, attendre au moins 30 minutes pour que le système refroidisse avant d'effectuer l'entretien.

- Respecter les règles de sécurité et d'entretien mentionnées au début du guide d'utilisation!

Battery Warning

Caution!



- Batteries are at risk of exploding if incorrectly installed
- Do not attempt to recharge, force open, or heat the battery
- Replace the battery only with the same or equivalent type recommended by the manufacturer

Entretien et réparation

- La réparation du système ne peut être effectuée que par du personnel qualifié
- Avant de réparer le système, arrêter le système, débrancher le cordon d'alimentation et toutes les autres connexions
- Lors du remplacement ou de l'installation de composants supplémentaires (carte d'extension, module de mémoire, etc.), les insérer le plus doucement possible tout en s'assurant que les connecteurs sont bien engagés jusqu'au bout

ESD Precautions

- Handle add-on module, motherboard by their retention screws or the module's frame/ heat sink. Avoid touching the PCB circuit board or add-on module connector pins
- Use a grounded wrist strap and an anti-static work pad to discharge static electricity when installing or maintaining the system
- Avoid dust, debris, carpets, plastic, vinyl and styrofoam in your work area.
- Do not remove any module or component from its anti-static bag before installation

Précautions nécessaires de décharge électrostatique (ESD)

- Tenir le module complémentaire et la carte mère par leurs vis de rétention ou le châssis/dissipateur de chaleur du module. Éviter de toucher la carte de circuit imprimé ou les broches du connecteur du module complémentaire
- Afin de décharger l'électricité statique, utiliser une dragonne mise à la terre et un tapis de travail antistatique lors de l'installation ou de l'entretien du système
- Éviter la poussière, les débris, les tapis, le plastique, le vinyle et la mousse de polystyrène dans votre zone de travail.
- Ne retirer aucun module ou composant de son sac antistatique avant l'installation

Restricted Access Location

The controller is intended for installation only in certain environments where both of the following conditions apply:

- Access can only be gained by QUALIFIED SERVICE PERSONNEL who have been instructed on the reasons for restrictions applied to the location and any precautions that shall be taken
- Access is through the use of a TOOL, lock and key, or other means of security, and is controlled by the authority responsible for the location

Lieu d'accès restreint

Le contrôleur doit être installé uniquement dans les environnements où les deux conditions suivantes sont présentes :

- Le lieu ne peut être accédé que par du PERSONNEL TECHNIQUE QUALIFIÉ informé des raisons des restrictions appliquées à l'emplacement et des précautions à prendre
- L'accès est contrôlé par l'autorité responsable de l'emplacement et se fait au moyen d'un OUTIL, d'une serrure et d'une clé ou d'autres moyens de sécurité

About This Manual

This manual introduces GT-92 series systems that support an Intel® 14th/ 13th/ 12th Gen Core processor and up to 64GB ECC/ non-ECC DDR5 memory. The system also supports an NVIDIA® RTX 2000 ADA inference accelerator for AI computation capability. This manual introduces and demonstrates the system's installation procedures.

Revision History

Version	Date	Description
1.0	Feb. 2025	Initial release
1.1	Jul. 2025	Updated EN 50155 specifications
1.2	Aug. 2025	Updated packing list
1.3	Dec. 2025	Updated grounding procedure and cable specifications

1 Introduction

GT-92 series systems are 19" rack mount, wide-temperature, fanless GPU computers that deliver excellent CPU and GPU performance by leveraging Intel® 14th/ 13th/ 12th-Gen platform and NVIDIA® RTX 2000 ADA. Thanks to high-performance and flexible camera expansion, GT-92GC is ideal for multi-camera applications requiring real time responses, e.g., AI inspection, robotic guidance, and autonomous machines; GT-92RL-H is ideal for multi-camera applications requiring real time responses in rolling stock applications, e.g., pantograph and track gauge monitoring, video analytics in train carriages, track object identification, and tunnel inspection, etc.

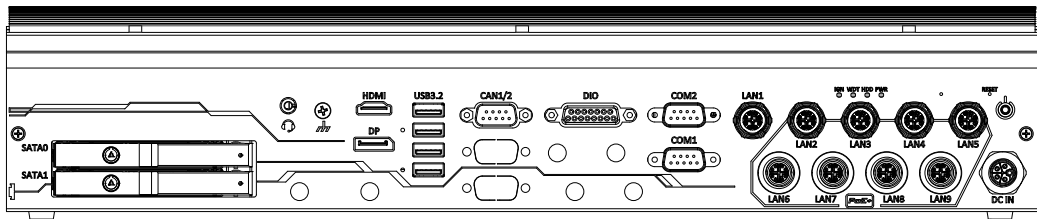

GT-92GC

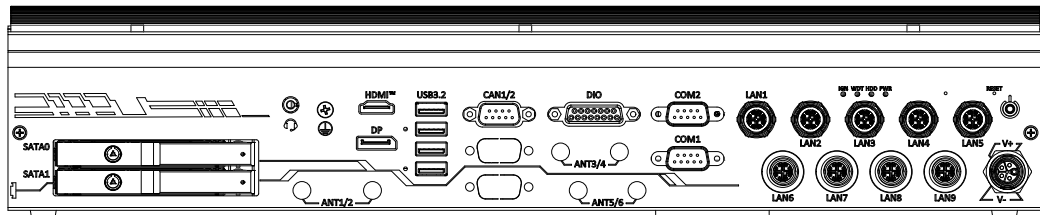

GT-92RL-H

GT-92 series systems have a proven thermal design to guarantee reliable system operation, with GT-92GC capable of operating from -25°C to 55°C , and GT-92RL-H operating from -40°C to 55°C . The systems feature a passive-cooling design for the motherboard and 70W GPU card. Supporting eight GigE cameras (or IP cameras) and four USB3 cameras, GT-92 series systems are ideal for various vision-based AI application deployments. Furthermore, GT-92RL-H. The systems also provide flexible data storage options, including one M.2 2280 Gen4x4 NVMe providing up to 7000 MB/s extreme read/write speeds and two 2.5" SATA HDD/SSD to expand storage capacity.

With performance enhancements and comprehensive I/Os, GT-92GC is the perfect edge AI inference platform for industrial environments such as inspection vehicle, smart agriculture, and autonomous machines; while GT-92RL-H has a 110V DC input design and EN 50155/ EN 45545 certifications making it the ideal edge AI inference platform for rolling stock applications

1.1 Product Specifications

1.1.1 GT-92GC Specifications

System Core	
Processor	Supports Intel® 14th-Gen Core™ CPU (LGA1700 socket, 65W/ 35W TDP) - Intel® Core™ i9-14900/ i9-14900T - Intel® Core™ i7-14700/ i7-14700T - Intel® Core™ i5-14500/ i5-14400/ i5-14500T - Intel® Core™ i3-14100/ i3-14100T
	Supports Intel® 13th-Gen Core™ CPU (LGA1700 socket, 65W/ 35W TDP) - Intel® Core™ i9-13900E/ i9-13900TE - Intel® Core™ i7-13700E/ i7-13700TE - Intel® Core™ i5-13500E/ i5-13400E/ i5-13500TE - Intel® Core™ i3-13100E/ i3-13100TE
	Supports Intel® 12th-Gen Core™ CPU (LGA1700 socket, 35W/ 65W TDP) - Intel® Core™ i9-12900E/ i9-12900TE - Intel® Core™ i7-12700E/ i7-12700TE - Intel® Core™ i5-12500E/ i5-12500TE - Intel® Core™ i3-12100E/ i3-12100TE - Intel® Pentium® G7400E/ G7400TE - Intel® Celeron® G6900E/ G6900TE
Chipset	Intel® R680E platform controller hub
Graphics	Integrated Intel® UHD Graphics 770 (32EU)
Acceleration GPU	NVIDIA® RTX 2000 ADA
Memory	Up to 64GB ECC/ non-ECC DDR5 4800 SDRAM (two SODIMM slots)
AMT	Supports Intel vPro/ AMT 16.0
TPM	Supports dTPM 2.0
I/O Interface	
Ethernet port	1x GbE Ethernet by Intel I219-LM via M12 x-coded connector (with WoL) 8x GbE Ethernet by Intel I350-AM4 via M12 x-coded connectors
PoE+	8x IEEE 802.3at PoE+ PSE with - with 70 W total power budget * (12V vehicle power input) - with 100 W total power budget (24V vehicle power input)

CAN bus	2x isolated CAN 2.0 port, supporting SocketCAN in Linux
USB	4x USB 3.2 Gen2x1 (10 Gbps) ports in type-A connectors
Video Port	1x HDMI 1.4, supporting 4096x2160 resolution 1x DisplayPort, supporting 4096 x 2304 resolution
Serial Port	2x isolated 3-wire RS232/ 422/ 485 port (COM1/ COM2)
Audio	1x 3.5 mm jack for mic-in and speaker-out
Storage Interface	
SATA HDD	2x hot-swappable HDD trays for 2.5" HDD/ SSD installation, supporting RAID 0/ 1
M.2 NVMe	1x M.2 2280 M key NVMe socket (PCIe Gen4x4) for NVMe SSD
Expansion Bus	
Mini PCI-E	2x full-size mini PCI Express socket with SIM slot
Power Supply	
DC Input	8V to 48V DC input (M12 L-coded)
Ignition Control	Built-in ignition power control
Maximum Power Consumption	With i7-12700 (65W mode): 141.4W (Max.) @ 24V With i7-12700 (65W mode): 146.4W (Max.) @ 48V With i7-12700TE (35W mode): 106.6W (Max.) @ 24V With i7-12700TE (35W mode): 111.8W (Max.) @ 48V With i5-12400 (35W mode): 105.1W (Max.) @ 24V With i5-12400 (35W mode): 110.9W (Max.) @ 48V With i5-12400 (65W mode): 120.5W (Max.) @ 24V With i5-12400 (65W mode): 126.2W (Max.) @ 48V
Mechanical	
Dimension	440 mm (W) x 249 mm (D) x 88 mm (H) (excl. rack-mount bracket)
Weight	7.7 kg
Mounting	Rack-mounting or wall-mounting
Environmental	
Operating Temperature	With 35W CPU -25°C to 55°C *** (without PoE) -25°C to 50°C *** (with PoE 50W) With 65W CPU -25°C to 35°C **/ *** (without PoE)
Storage Temperature	-40°C to 85°C
Humidity	10% to 90%, non-condensing
Vibration	EN 50155:2021/ IEC 61373, Category I, Class B - Body mounted

Shock	EN 50155:2021/ IEC 61373, Category I, Class B - Body mounted
EMC	EN 50121 (EN 50155 EMC) CE/FCC Class A, according to EN 55032 & EN 55035

* The 12V vehicle power input system imposes a strict limit of 70W on the PoE power budget due to the high current draw caused by the voltage drop to 8V.

** For 65W CPUs, the recommended DC input range is 18V to 48V.

*** For sub-zero operating temperature, a wide temperature HDD or Solid State Disk (SSD) is required.

1.1.2 GT-92RL-H Specification

System Core	
Processor	Supports Intel® 14th-Gen Core™ CPU (LGA1700 socket, 65W/ 35W TDP) - Intel® Core™ i9-14900/ i9-14900T - Intel® Core™ i7-14700/ i7-14700T - Intel® Core™ i5-14500/ i5-14400/ i5-14500T - Intel® Core™ i3-14100/ i3-14100T
	Supports Intel® 13th-Gen Core™ CPU (LGA1700 socket, 65W/ 35W TDP) - Intel® Core™ i9-13900E/ i9-13900TE - Intel® Core™ i7-13700E/ i7-13700TE - Intel® Core™ i5-13500E/ i5-13400E/ i5-13500TE - Intel® Core™ i3-13100E/ i3-13100TE
	Supports Intel® 12th-Gen Core™ CPU (LGA1700 socket, 35W/ 65W TDP) - Intel® Core™ i9-12900E/ i9-12900TE - Intel® Core™ i7-12700E/ i7-12700TE - Intel® Core™ i5-12500E/ i5-12500TE - Intel® Core™ i3-12100E/ i3-12100TE - Intel® Pentium® G7400E/ G7400TE - Intel® Celeron® G6900E/ G6900TE
Chipset	Intel® R680E platform controller hub
Graphics	Integrated Intel® UHD Graphics 770 (32EU)
Acceleration GPU	NVIDIA® RTX 2000 ADA
Memory	Up to 64GB ECC/ non-ECC DDR5 4800 SDRAM (two SODIMM slots)
AMT	Supports Intel vPro/ AMT 16.0
TPM	Supports dTPM 2.0
I/O Interface	
Ethernet port	1x GbE Ethernet by Intel I219-LM via M12 x-coded connector (with WoL) 8x GbE Ethernet by Intel I350-AM4 via M12 x-coded connectors
CAN bus	2x isolated CAN 2.0 port, supporting SocketCAN in Linux
USB	4x USB 3.2 Gen2x1 (10 Gbps) ports in type-A connectors
Video Port	1x HDMI 1.4, supporting 4096x2160 resolution 1x DisplayPort, supporting 4096 x 2304 resolution
Serial Port	2x isolated 3-wire RS232/ 422/ 485 port (COM1/ COM2)
Audio	1x 3.5 mm jack for mic-in and speaker-out

Storage Interface	
SATA HDD	2x hot-swappable HDD trays for 2.5" HDD/ SSD installation, supporting RAID 0/ 1
M.2 NVMe	1x M.2 2280 M key NVMe socket (PCIe Gen4x4) for NVMe SSD
Expansion Bus	
Mini PCI-E	2x full-size mini PCI Express socket with SIM slot
Power Supply	
DC Input	43V to 160V DC input (M12 K-coded)
Maximum Power Consumption	With i7-12700 (65W mode): 141.4W (Max.) @ 24V With i7-12700 (65W mode): 146.4W (Max.) @ 48V With i7-12700TE (35W mode): 106.6W (Max.) @ 24V With i7-12700TE (35W mode): 111.8W (Max.) @ 48V
Mechanical	
Dimension	440 mm (W) x 249 mm (D) x 88 mm (H) (excl. rack-mount bracket)
Weight	8.0 kg
Mounting	Rack-mounting or wall-mounting
Environmental	
Operating Temperature	With 35W CPU -40°C to 55°C *, compliant with EN 50155 Class OT2 With 65W CPU -40°C to 35°C *
Storage Temperature	-40°C to 85°C
Humidity	10% to 90%, non-condensing
Vibration	EN 50155:2021/ IEC 61373, Category I, Class B - Body mounted
Shock	EN 50155:2021/ IEC 61373, Category I, Class B - Body mounted
EMC	EN 50121 (EN 50155 EMC) CE/FCC Class A, according to EN 55032 & EN 55035
EN 50155	All mandatory sections of EN 50155:2021 (110V) Interruptions of voltage supply Class S3: 0V/ 20ms Supply change-over Class C2: 0V/ 30ms Voltage withstand test: 1500V DC
EN 45545	EN 45545-2 (Fire protection on railway vehicles)

*For sub-zero operating temperature, a wide temperature HDD or Solid State Disk (SSD) is required.

1.2 GT-92 Series Dimension



NOTE

GT-92 series systems share the same dimensions. GT-92GC is shown here.

All measurements are in millimeters (mm).

1.2.1 GT-92 Series Front Panel View

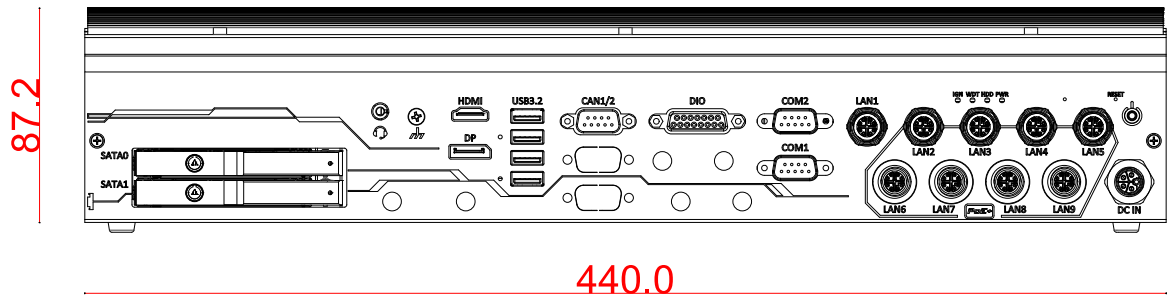

1.2.2 GT-92 Series Rear Panel View

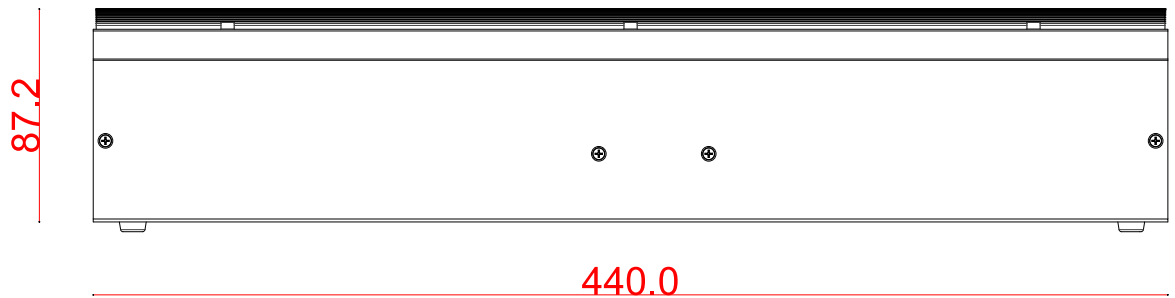

1.2.3 GT-92 Series Top View

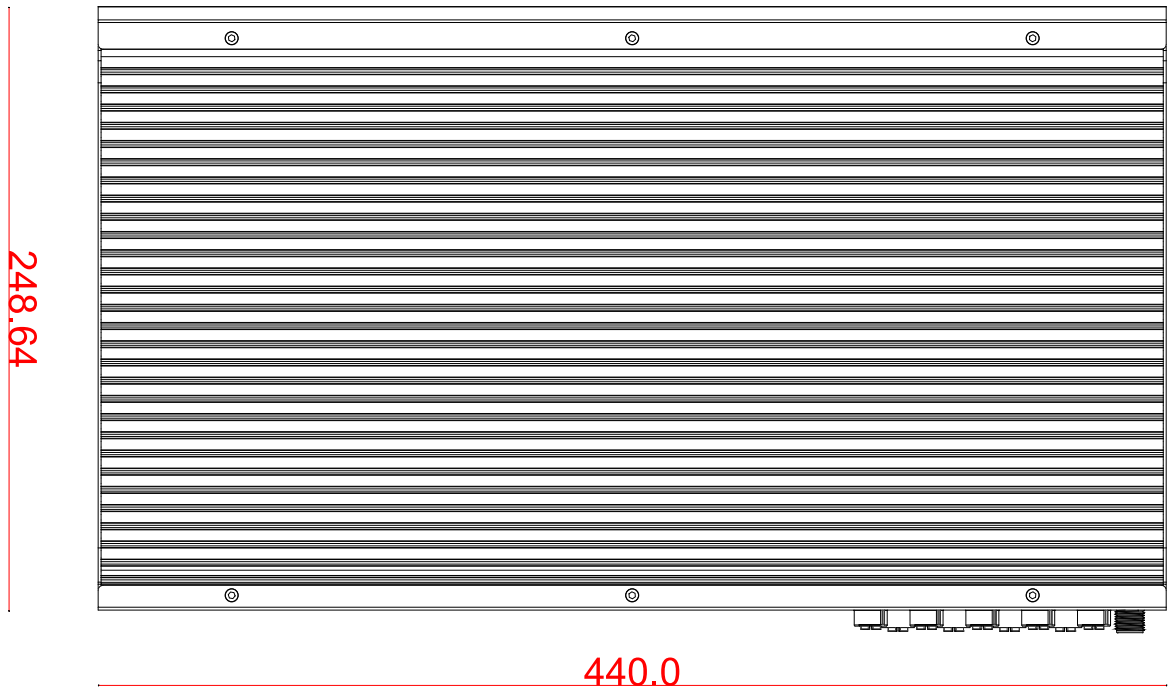

1.2.4 GT-92 Series Bottom View

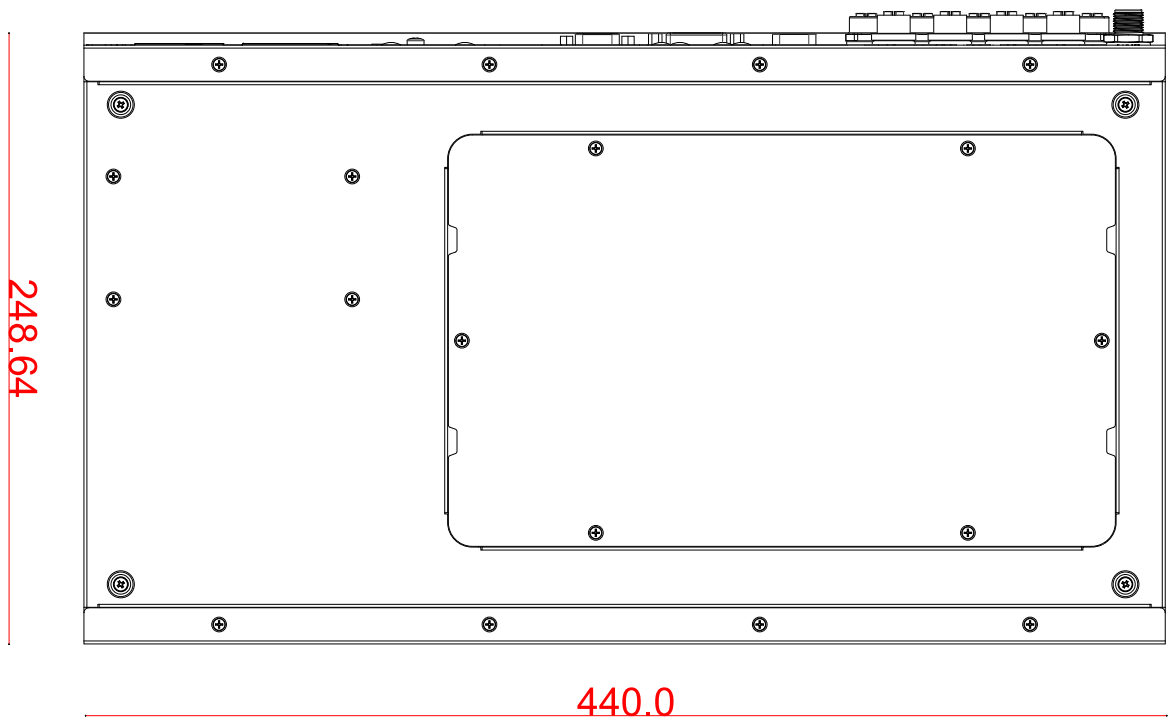

1.4 GT-92 Series Dimensions with Wall Mount Bracket

 **NOTE**

GT-92 series systems share the same dimensions. GT-92GC is shown here.

All measurements are in millimeters (mm).

1.4.1 GT-92 Series Front View with Wall Mount Bracket

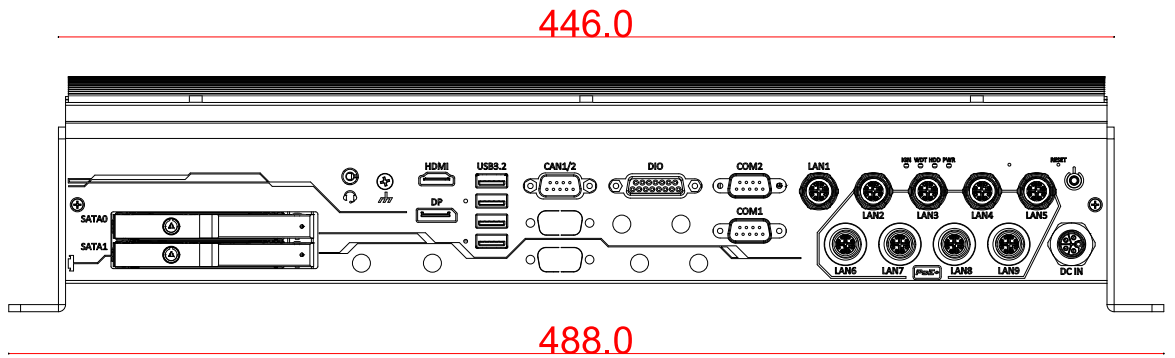

1.4.2 GT-92 Series Side View with Wall Mount Bracket

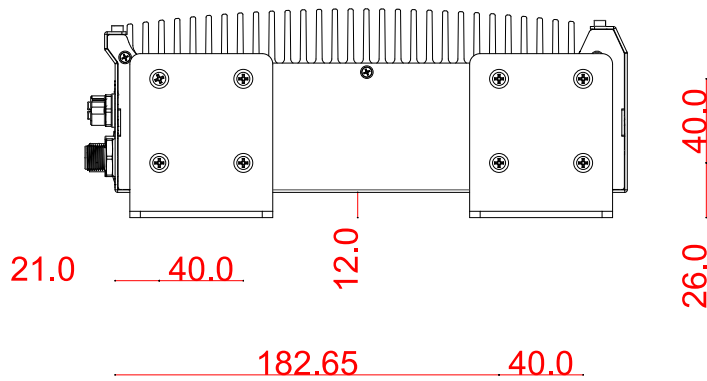

2 System Overview

Upon receiving and unpacking your GT-92 series system, please check immediately if the package contains all the items listed in the following table. If any item(s) are missing or damaged, please contact your local dealer or Neousys Technology.

2.1 Packing List

2.1.1 GT-92 Series Packing List

System Pack	GT-92 Series	Qty
1	GT-92 series system (If you ordered CPU/ RAM/ HDD, please verify these items)	1
2	Accessory box, which contains <ul style="list-style-type: none"> ● CPU bracket ● Screw pack ● HDD/ SSD tray key ● GT-92GC: DC-IN cable, M12 L-coded Female 5P to Cord End Terminal 5P, 180cm ● GT-92RL-H: DC-IN cable, M12 K-coded Female 5P to Cord End Terminal 4P, 180cm 	1 1 2 1 1

2.2 Front Panel I/O

 **NOTE**

GT-92 series systems share the similar I/Os and differences will be shown. GT-92GC will be used for demonstration purposes.

The GT-92 Series systems' front panel features the following external I/O connections.

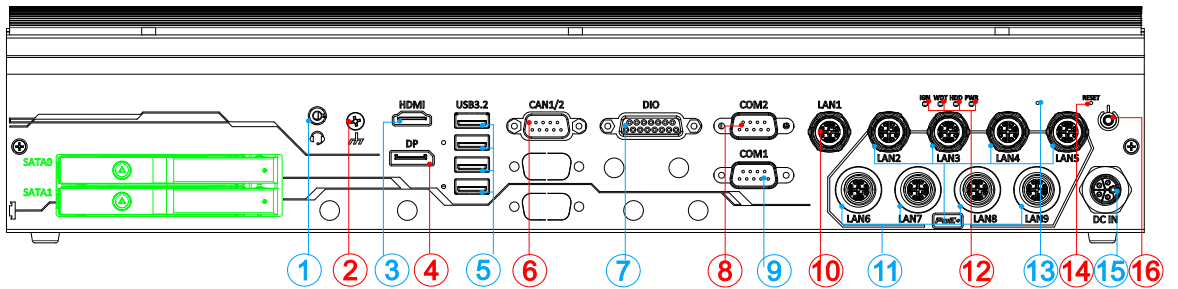

No.	Item	Description
		Two 2.5" easy-swappable HDD trays for 2.5" HDD/ SSD installation (supports up to 7mm drive thickness)
1	4-pole 3.5mm headphone/microphone jack	The 4-pole 3.5mm jack accepts microphone voice input and headphone speaker sound output
2	Grounding point	Chassis grounding point: alternative M4 screws may be used to secure electrical ground ring
3	HDMI	The HDMI port is a high-resolution graphics/ data port supporting up to 3840 x 2160 @ 30Hz
4	DisplayPort	Support display resolutions up to 4096 x 2304 @ 60Hz. Compatible with HDMI/ DVI via respective adapter/ cable (resolution may vary)
5	USB3.2 port	USB3.2 Gen2x1 port (SuperSpeed+) offers up to 10Gbps, twice the bandwidth over existing SuperSpeed USB3.2 Gen1 connection. It is also backwards compatible with USB3.0 and USB2.0
6	CAN1/ 2	The CAN bus 2.0 connectivity allows the system to communicate with other CAN devices
7	Digital Input/ Output	Isolated 4 channel digital input and output
8	COM2	A software-selectable RS-232/422/485 port, the operation mode can be set in the BIOS

9	COM1	A software-selectable RS-232/422/485 port, the operation mode can be set in the BIOS
10	Ethernet 1	GbE Ethernet by Intel I219-LM via M12 x-coded connector (with WoL)
11	Ethernet 2-9	GbE Ethernet by Intel I350-AM4 via M12 x-coded connectors
12	Status LEDs	From left to right, the LEDs are four status LEDs on the front panel: ignition control (IGN), Watchdog timer (WDT), hard disk drive (HDD), and power (PWR)
13	Clear CMOS button	Use this button to manually to reset the CMOS to load default BIOS
14	Reset button	Use this button to manually reset the system
15	DC input	GT-92GC : M12 L-coded 8V to 48V DC input with built-in ignition power control GT-92RL-H : M12 K-coded 43V to 160V DC input
16	Power button	Use this button to turn on or shutdown the system.

2.2.1 2.5” HDD Tray

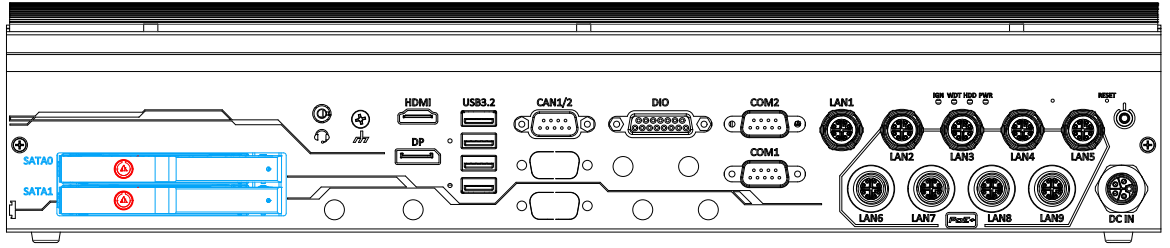



There are four 2.5 inch easy-swap hard drive trays on the front IO panel. Each 2.5” tray supports a 2.5” HDD or SSD up to 7mm thick. There is a lock (indicated in **red**) for each tray. When installing an HDD/ SSD, please make sure to insert the SATA connector end into the enclosure first.

 **NOTE**

The trays support hard drives with up to 7mm thickness.

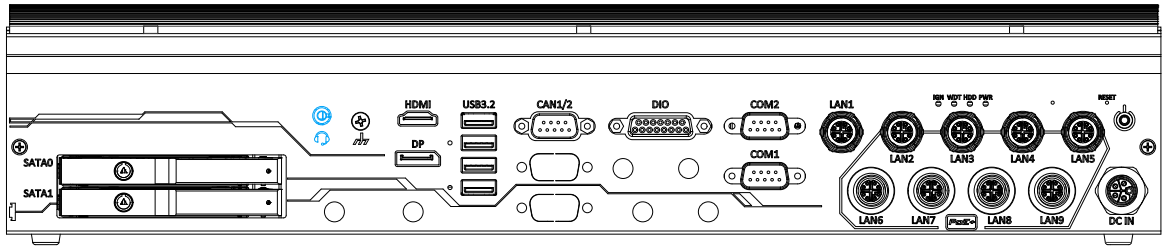
2.2.2 4-pole 3.5mm Headphone/ Microphone Jack



The system audio function uses high definition audio. There is a female 4-pole  audio jack for headphone (speaker) output and microphone input. The HD audio codec is natively supported in Windows 10 and Windows 11, and no additional drivers are required to enable the audio function on the system.

2.2.3 Grounding Point

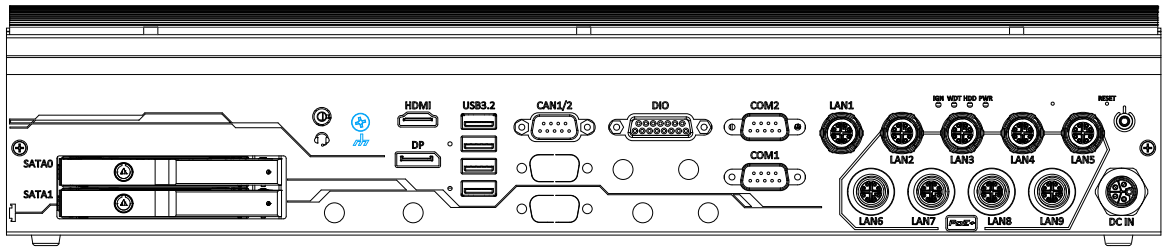

GT-92GC

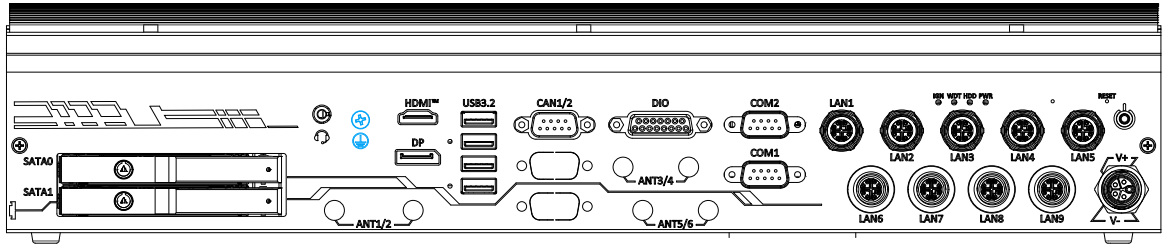

GT-92RLH

The system offers EMI protection with an isolated PCB design. If you are powering the system using an isolated power supply, please make sure the chassis grounding point is connected.

2.2.5 DisplayPort

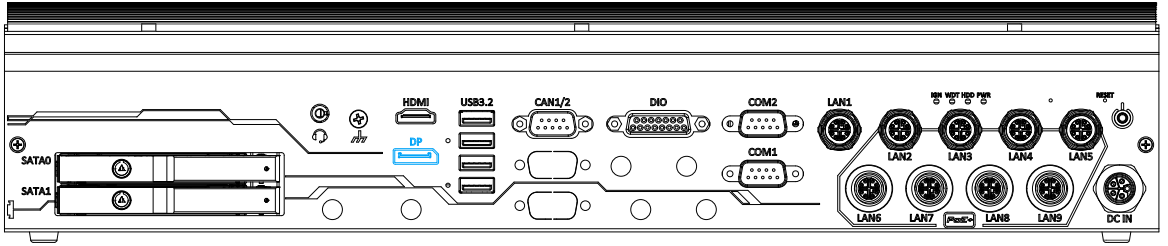

The system has a DisplayPort (DP) output which is a digital display interface that mainly connect video source and carry audio to a display device. When connecting a DP, it can deliver up to 4K UHD (4096 x 2160 @ 60Hz) in resolution. The system is designed to support passive DP adapter/ cable. You can connect to other display devices using DP-to-HDMI cable or DP-to-DVI cable.



DP-to-HDMI



DP-to-DVI

The system supports dual independent display outputs by connecting display devices to HDMI and DisplayPort connection. To support dual display outputs and achieve best DisplayPort output resolution in Windows, you need to install corresponding graphics drivers. Please refer to section [OS Support and Driver Installation](#) for details.

2.2.6 USB3.2 Gen2x1 Port

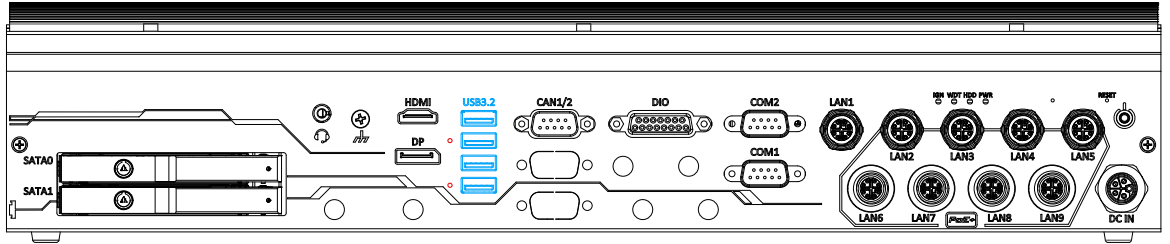

The system's USB 3.2 Gen2x1 ports (10Gbps) are implemented via native xHCI (eXtensible Host Controller Interface) controller and are backward compatible with USB3.2 Gen1 USB 2.0, USB 1.1 and USB 1.0 devices. UEFI USB is also supported so you can use USB keyboard/ mouse in UEFI shell environment. Indicated in **red** are screw-lock holes for the corresponding USB port.

xHCI driver is supported natively in Windows 10, therefore you do not need to install the xHCI driver prior to utilizing USB functions

2.2.7 CAN Port 1/ 2

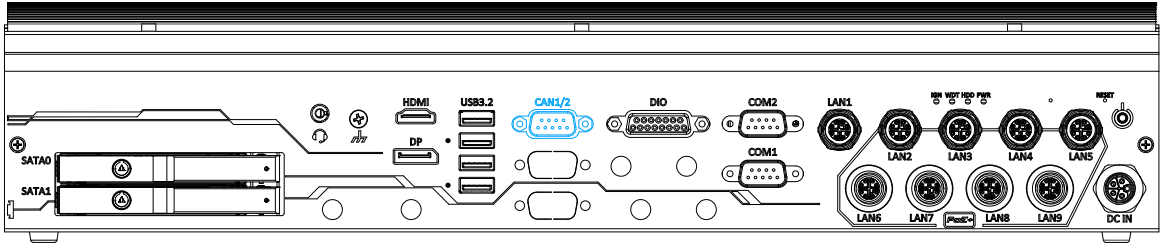

CAN bus is a robust industrial bus with a pair of differential signals and is commonly used in various industrial and in-vehicles applications. The CAN bus port supports CAN2.0A and CAN2.0B up to 1Mbps.

CAN bus is a robust industrial bus with a pair of differential signals and is commonly used in various industrial and in-vehicles applications. The system is equipped with a CAN bus DB9 port that is compatible with both industrial and in-vehicle applications. The CAN bus port supports CAN2.0A and CAN2.0B up to 1Mbps.

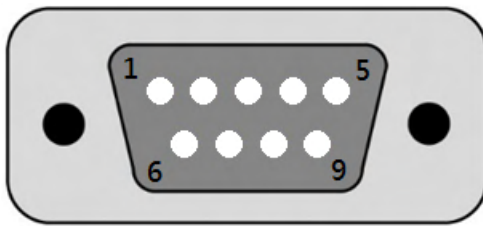

Pin No.	Definition	I/O	Description
1	-	-	Reserved pin. Keep unconnected
2	CAN1_L	I/O	CAN Bus1 Low-level voltage
3	-	-	Reserved pin. Keep unconnected
4	CAN2_L	I/O	CAN Bus2 Low-level voltage
5	-	-	Reserved pin. Keep unconnected
6	CAN1_GND	-	CAN bus1 ground
7	CAN1_H	I/O	CAN Bus1 high-level voltage
8	CAN2_H	I/O	CAN Bus2 high-level voltage
9	CAN2_GND	-	CAN bus2 ground

2.2.8 Digital Input/ Output

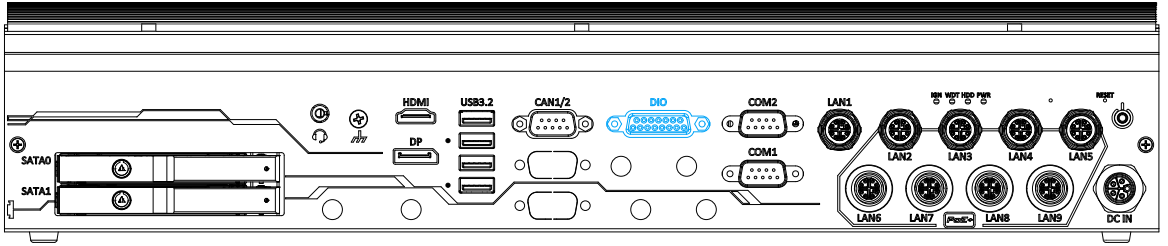

The digital input (DI) and digital output (DO) function provides four digital input and four digital output on the rear panel of the system via DB15 female connector.

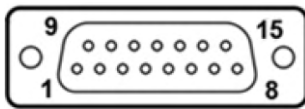

Pin Definition

Pin#	Pin Definition	Pin#	Pin Definition
1	VDD	9	ISO_DO0_CN
2	ISO_DO1_CN	10	DO0_COM
3	DO1_COM	11	ISO_DO2_CN
4	ISO_DO3_CN	12	DO2_COM
5	DO3_COM	13	ISO_DI0_CN
6	ISO_DI1_CN	14	DI_GND
7	DI_GND	15	ISO_DI2_CN
8	ISO_DI3_CN		

Digital Input Wiring

Channel	4
Type	Sink mode
Interface	Unipolar Photocoupler
Isolation Voltage	2500Vrms
Rated Input Voltage	0V-24V
Logic High Voltage	5V-24V
Logic Low Voltage	0V-1.5V
Operation Mode	Polling
Response Time (Rise)	3us
Response Time (Fall)	3us

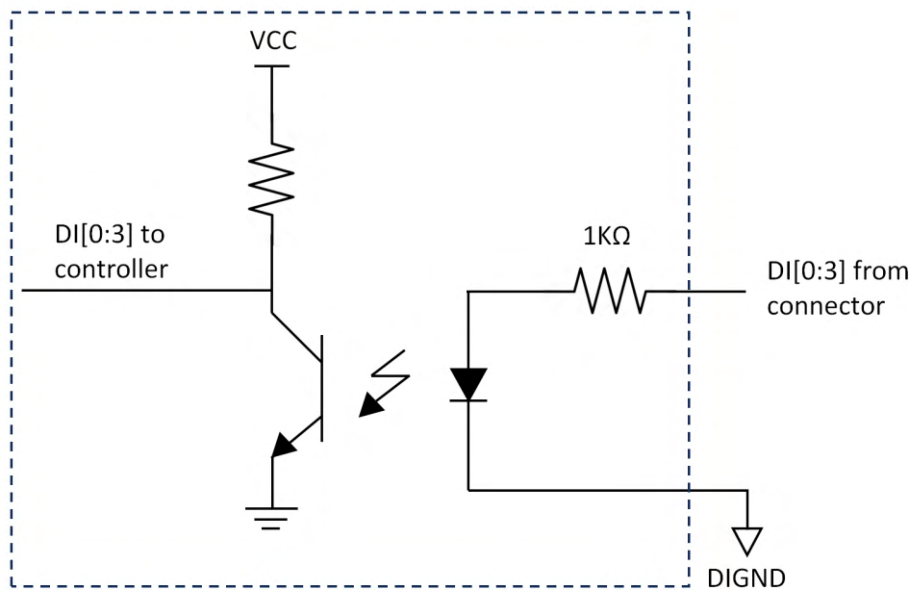

Digital Output Wiring

Channel	4
Type	Sink mode
Interface	Bidirectional PhotoMOS
Isolation Voltage	1500V AC
Operation Voltage	0V-24V
Driving Current	250mA
Operation Mode	Polling
Response Time (Turn on)	660us ~ 2ms
Response Time (Turn off)	90us ~ 210us

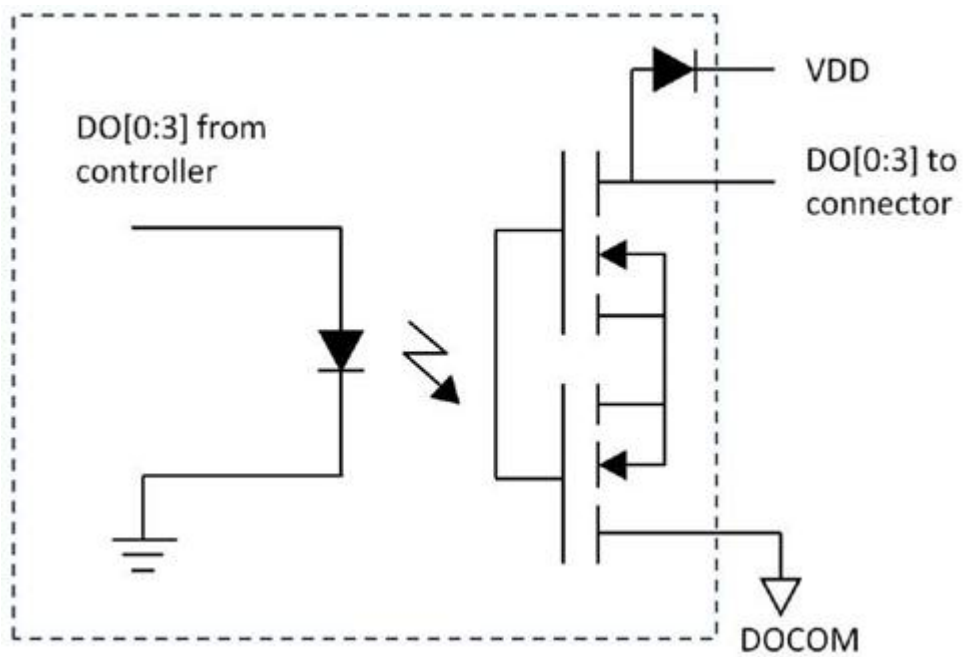

2.2.9 COM 1/ 2 Port

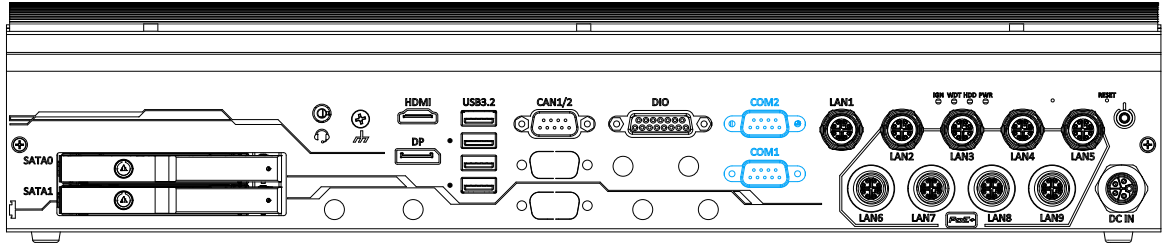

The system provides two software-configurable RS-232/ 422/ 485 COM ports for communicating with external devices. These COM ports are implemented using industrial-grade ITE8786 Super IO chip (-40 to 85°C) and provide up to 115200 bps baud rate.

The operation mode of COM1 and COM2 can be set in BIOS setup utility. The following table describes the pin definition of COM ports.

COM Port Pin Definition

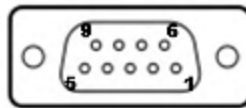

COM1 & COM2			
Pin#	RS-232 Mode	RS-422 Mode	RS-485 Mode (Two-wire 485)
1	DCD		
2	RX	422 TXD+	485 TXD+/RXD+
3	TX	422 RXD+	
4	DTR	422 RXD-	
5	GND	GND	GND
6	DSR		
7	RTS		
8	CTS	422 TXD-	485 TXD-/RXD-
9	RI		

2.2.10 M12 X-coded Gigabit Ethernet Port 1

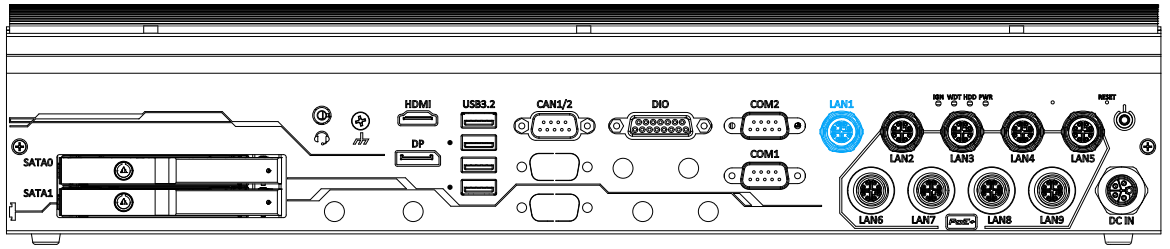

Ethernet port 1 is an M12 X-coded connector implemented using Intel i219-LM. It supports Wake on LAN (WoL) and is also compatible with Intel® AMT (Active Management Technology) to support advanced features such as remote SOL desktop and remote on/ off control.

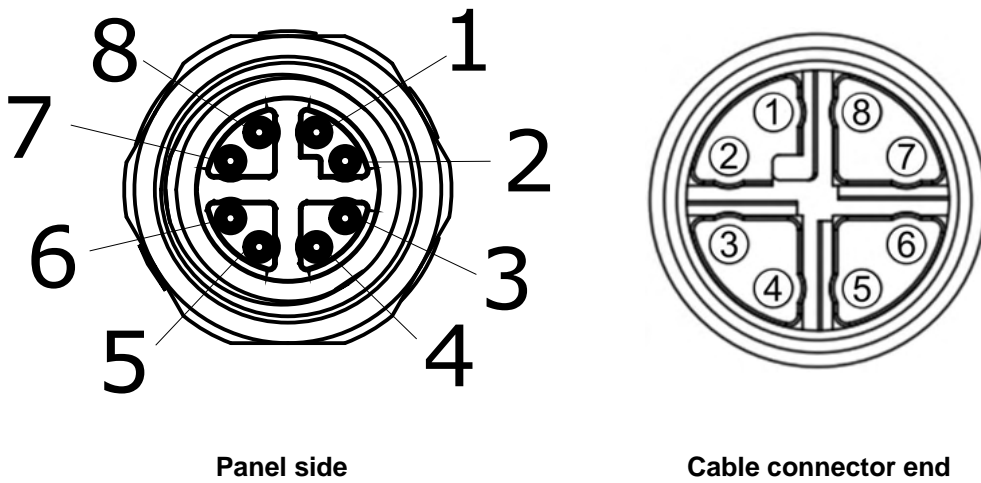

Signal	M12 panel side	M12 cable connector end	Wire color
LAN P0	1	1	Yellow
LAN N0	2	2	Yellow
LAN P1	3	3	Green
LAN N1	4	4	Green
LAN P3	5	5	Orange
LAN N3	6	6	Orange
LAN N2	7	7	Blue
LAN P2	8	8	Blue

2.2.11 M12 X-coded Gigabit Power Over Ethernet Ports (2-9)

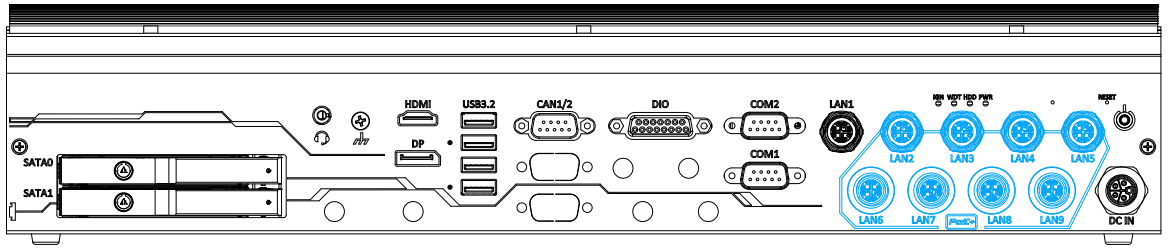

The system offers Gigabit ports with PoE+ via M12 X-coded connectors on the front panel. Power over Ethernet (PoE) supplies electrical power and data on a CAT-5/CAT-6 Ethernet cable. Acting as a PoE PSE (Power Sourcing Equipment), compliant with IEEE 802.3at, each PoE port delivers up to 25.5W to a Powered Device (PD). PoE can automatically detect and determine if the connected device requires power or not, so it is compatible with standard Ethernet devices as well.

Each port has one dedicated PCI Express link for maximum network performance.

Connector Pin Definition

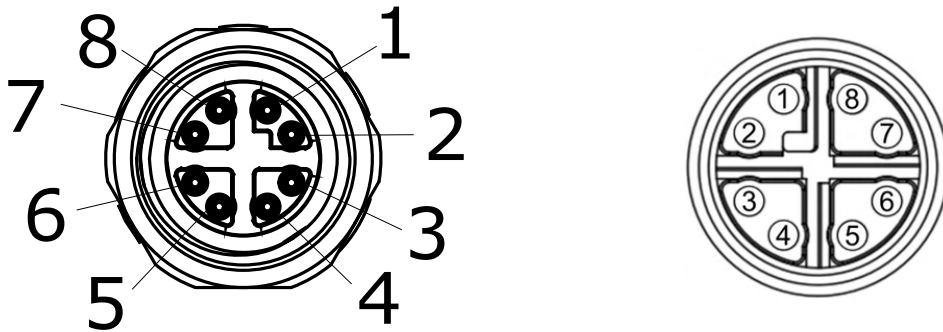

	Panel side	Cable connector end	
Signal	M12 panel side	M12 cable connector end	Wire color
LAN P0	1	1	
LAN N0	2	2	
LAN P1	3	3	
LAN N1	4	4	
LAN P3	5	5	
LAN N3	6	6	
LAN N2	7	7	
LAN P2	8	8	

2.2.12 System Status LED

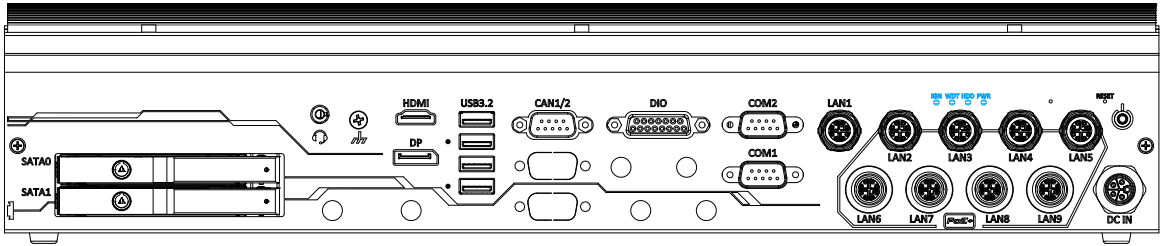

There are four LED indicators on the I/O panel: IGN (ignition power control), WDT (Watchdog Timer), HDD (hard disk drive), and PWR (power). The descriptions of these four LEDs are listed below:

Indicator	Color	Description
IGN	Yellow	Ignition signal indicator, lit when IGN is high (12V/ 24V)
WDT	Yellow	Watchdog timer LED, flashing when WDT is active
HDD	Red	Hard drive indicator, flashing when hard disk drive is active
PWR	Green	Power indicator, lit when system is on

2.2.13 Clear CMOS Button

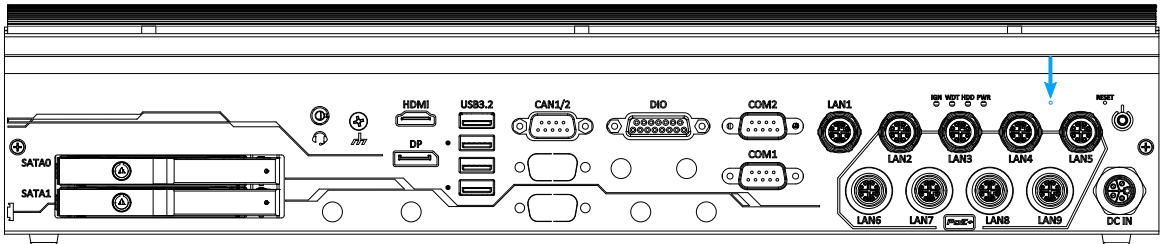

The CMOS Reset button is used to manually reset the motherboard BIOS in case of system halt or malfunction. To avoid unexpected operation, it is purposely placed behind the panel. To reset, disconnect the DC power input, and use the tip of a pen to press and hold for at least 5 seconds to reset the BIOS.

 **NOTE**

You **MUST** disconnect the DC input from the system before resetting the CMOS.

 **WARNING**

Clearing the CMOS will reset all BIOS settings to default and may result in down time!

2.2.14 Reset Button

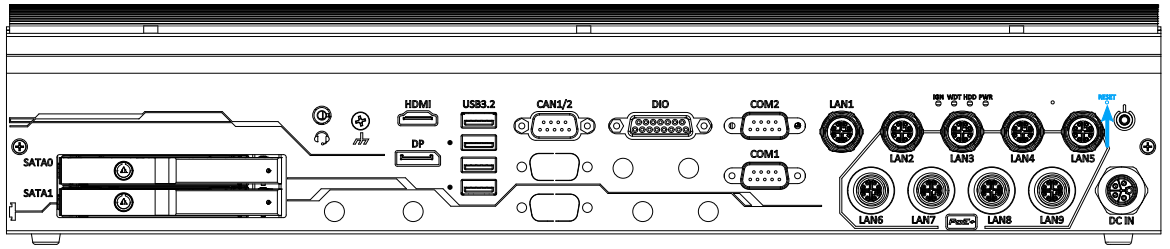

The reset button is used to manually reset the system in case of system halt or malfunction. To avoid unexpected reset, the button is purposely placed behind the panel. To reset, please use a pin-like object (eg. tip of a pen) to access the reset button

2.2.15 Power Button

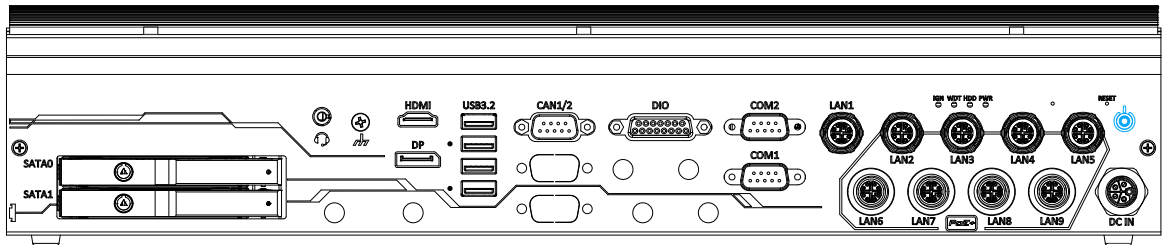

The power button is a non-latched switch for ATX mode on/off operation. To turn on the system, press the power button and the PWR LED should light-up green. To turn off the system, issuing a shutdown command in OS is preferred, or you can simply press the power button. To force shutdown when the system freezes, press and hold the power button for 5 seconds. Please note that there is a 5-second interval between on/off operations (i.e. once the system is turned off, there is a 5-second wait before you can power-on the system).

2.2.16 M12 L-coded DC Input (GT-92GC)

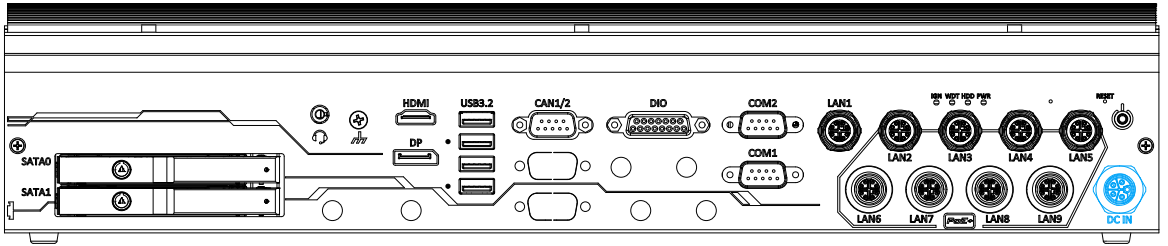

The system accepts a wide range of DC power input from 8V to 48V via a M12 L-coded connector. The M12 L-coded connectors offer COTS availability and ultra-rugged connection reliability when wiring DC power.

WARNING

Please make sure the voltage of DC power is correct before you connect it to the system. Supplying a voltage over 48V will damage the system.

Connector Pin Definition

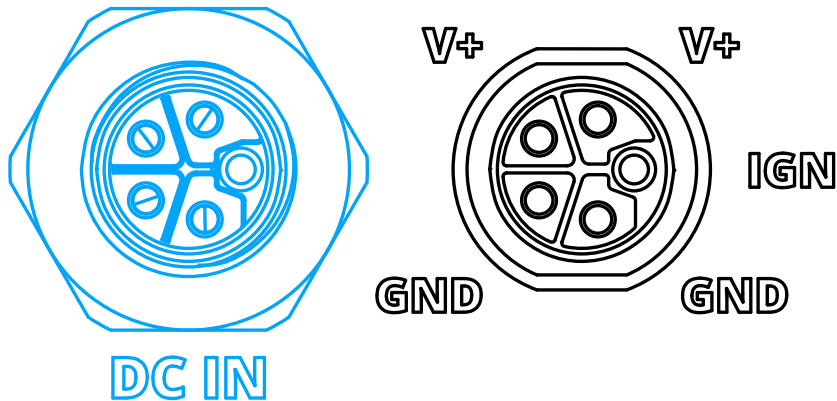

Signal	Wire color
IGN	Yellow
V+	Red
V+	Red
GND	Black
GND	Black

2.2.17 M12 K-coded DC Input (GT-92RL-H)

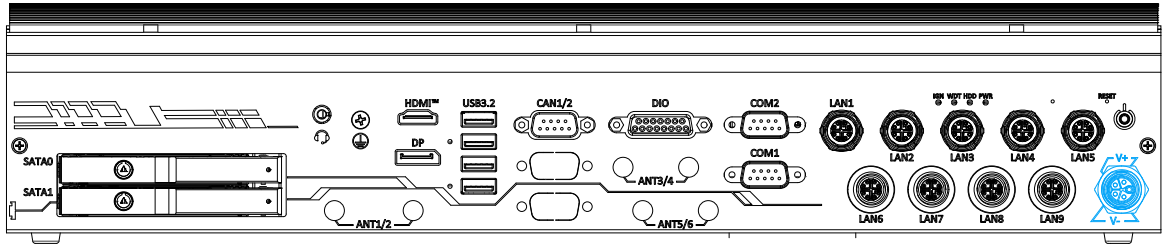

The system accepts a wide range of DC power input from 43V to 160V via a M12 K-coded connector. The M12 K-coded connectors offer COTS availability and ultra-rugged connection reliability when wiring DC power.

⚠ WARNING

Please make sure the voltage of DC power is correct before you connect it to the system. Supplying a voltage over 160V will damage the system.

Connector Pin Definition

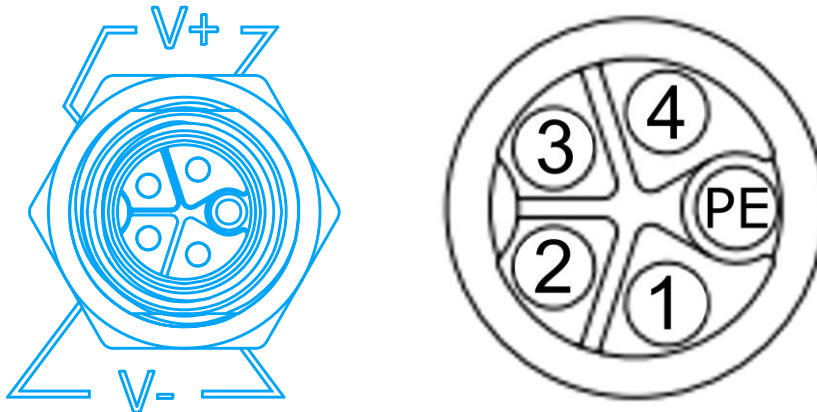

Pin	Signal	Wire color
PE	-	Yellow
4	V+	Red
3	V+	Red
2	GND	Black
1	GND	Black

2.3 Internal I/O Functions

In addition to I/O connectors on the front panel, the system also provides internal on-board connectors, such as mini-PCIe, M.2 NVMe slot, etc. In this section, we'll illustrate these internal I/O functions.

2.3.1 Mini-PCIe Socket & Pin Definition



The system provides mini-PCIe sockets (indicated in **blue rectangle**) that is in compliance with mini-PCIe specification rev. 1.2. Each mini-PCIe socket is designed with SIM card (slot indicated in **red rectangle**) support. With a SIM card installed, your system can access the internet via your network provider's 5G/ 4G network.

For wireless (WiFi/ 5G/ 4G) communication, multiple SMA antenna apertures (indicated in **blue circles**) can be located on the system panel.

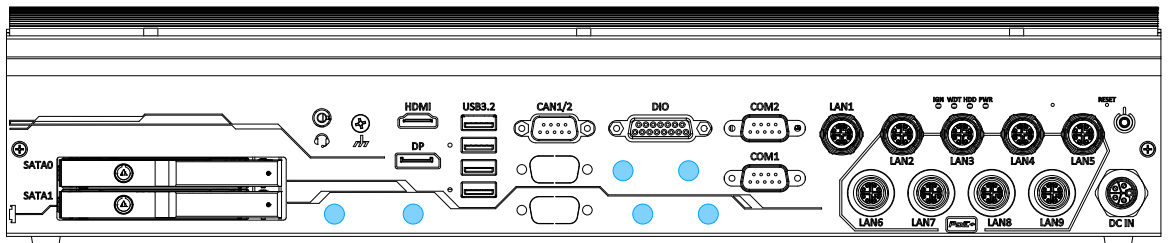

mini-PCle socket definition

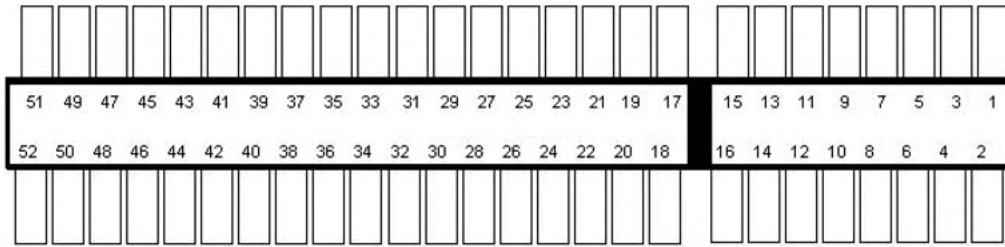

Pin	Signal (mPCle)	Pin #	Signal (mPCle)
1	WAKE#	2	+3.3Vaux
3	-	4	GND
5	-	6	+1.5V
7	CLKREQ#	8	UIM_PWR
9	GND	10	UIM_DATA
11	REFCLK-	12	UIM_CLK
13	REFCLK+	14	UIM_RESET
15	GND	16	UIM_VPP
Mechanical Key			
17	Reserved* (UIM_C8)	18	GND
19	Reserved* (UIM_C4)	20	W_DISABLE#
21	GND	22	PERST#
23	PERn0	24	3.3V
25	PERp0	26	GND
27	GND	28	+1.5V
29	GND	30	SMB_CLK
31	PETn0	32	SMB_DATA
33	PETp0	34	GND
35	GND	36	USB_D-
37	GND	38	USB_D+
39	3.3V	40	GND
41	3.3V	42	-
43	GND	44	-
45	Reserved	46	-
47	Reserved	48	+1.5V
49	Reserved	50	GND
51	Reserved	52	3.3V

 **WARNING**

Some off-the-shelf mini-PCle 5G/4G modules are not compliant to standard mini-PCle interface. They use 1.8V I/O signals instead of standard 3.3V I/O and may cause signal conflict. Please consult with Neosys for compatibility when in doubt! Installing an incompatible 5G/ 4G module may damage the system or the module itself may be damaged.

2.3.2 M.2 2280 (M Key) Slot for NVMe SSD



The system has a Gen4 x4 PCIe M.2 2280 slot (indicated in the **blue rectangle**, underneath the heat spreader) for you to install an NVMe SSD. The M.2 NVMe SSD offers significantly better system performances when compared to a 2.5" SSD.

M.2 (M Key) Slot Pin Definition

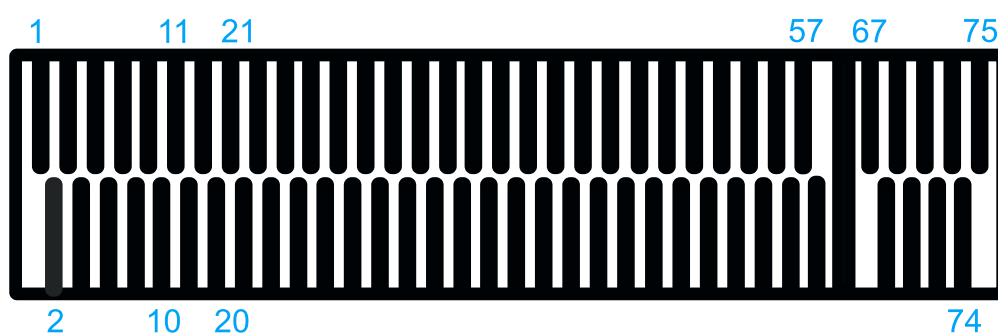

Pin #	Signal	Pin #	Signal
1	GND	2	+3V3
3	GND	4	+3V3
5	PERN3	6	-
7	PERP3	8	-
9	GND	10	DAS/DSS_N
11	PETN3	12	+3V3
13	PETP3	14	+3V3
15	GND	16	+3V3
17	PERN2	18	+3V3
19	PERP2	20	-
21	GND	22	-
23	PETN2	24	-
25	PETP2	26	-
27	GND	28	-
29	PERN1	30	-
31	PERP1	32	-
33	GND	34	-
35	PETN1	36	-
37	PETP1	38	-
39	GND	40	-
41	PERn0	42	-
43	PERp0	44	-
45	GND	46	-
47	PETn0	48	-
49	PETp0	50	PERST_N
51	GND	52	-
53	REFCLKN	54	-
55	REFCLKP	56	-
57	GND	58	-
Mechanical Key			
67	-	68	SUSCLK
69	PEDET	70	+3V3
71	GND	72	+3V3
73	GND	74	+3V3
75	GND		

2.3.3 Ignition Power Control Switch



The ignition power control switch features multiple modes for pre and post ignition settings. Please refer to the section Ignition Power Control for details. Please use a flathead screwdriver to adjust the position of the ignition power control switch.

For details, please refer to the section [Ignition Power Control](#) for details.

3 System Installation

Before disassembling the system enclosure and installing components and modules, please make sure you have done the following:

- It is recommended that only qualified service personnel should install and service this product to avoid injury or damage to the system.
- Please observe all ESD procedures at all times to avoid damaging the equipment.
- Before disassembling your system, please make sure the system has powered off, all cables and antenna (power, video, data, etc.) are disconnected.
- Place the system on a flat and sturdy surface (remove from mounts or out of server cabinets) before proceeding with the installation/ replacement procedure.

3.1 Removing the Bottom Panel

To access system internal expansion slots, the system's bottom panel needs to be removed. To do so, please refer to the following instructions:

1. Turn the system upside-down and remove the screws indicated at the bottom of the enclosure, and leverage one of the hinges (indicated by arrows) to pry open the panel.

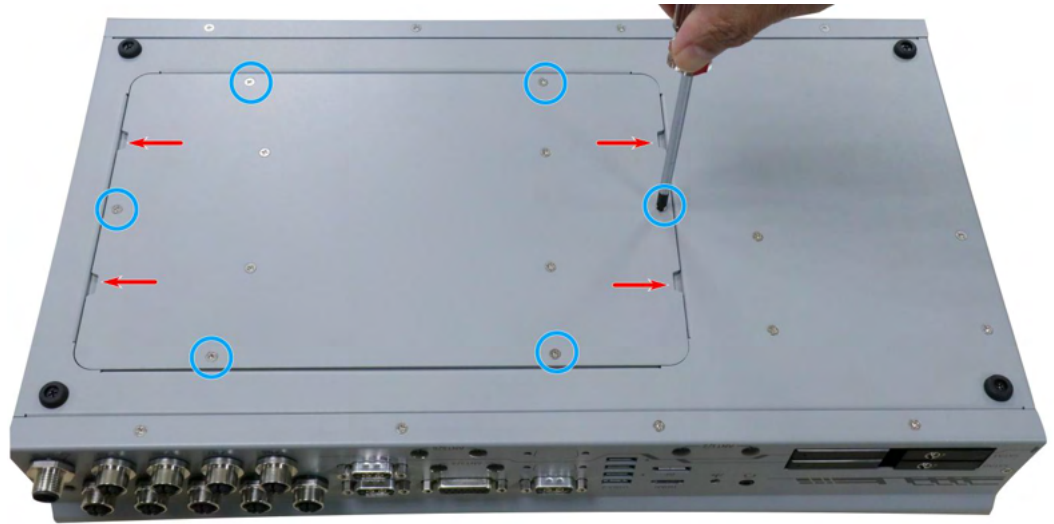

2. Gently pry open the bottom panel

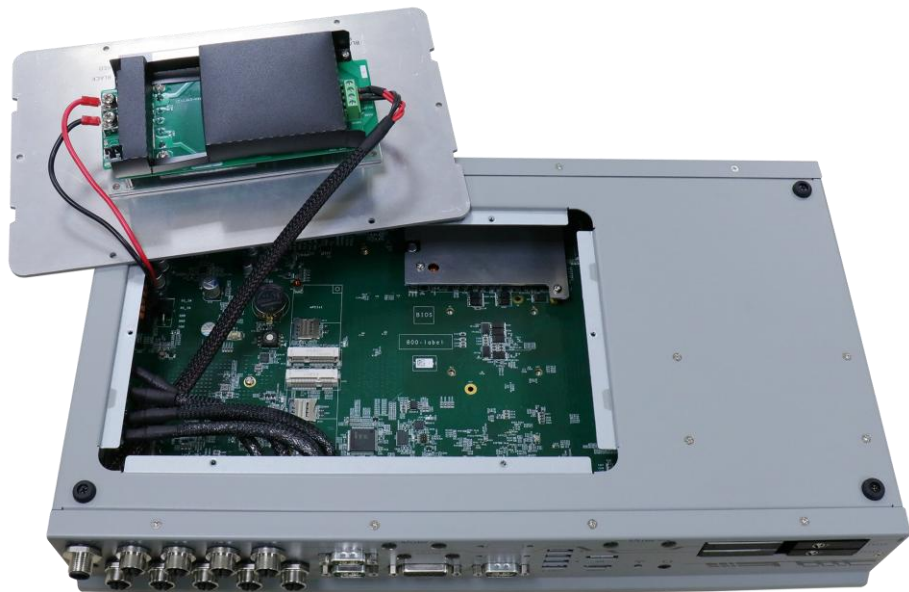

3. Place the panel next to the system, and you can now access the internal expansion slots of the system.



3.2 Grounding Procedure

Grounding Point

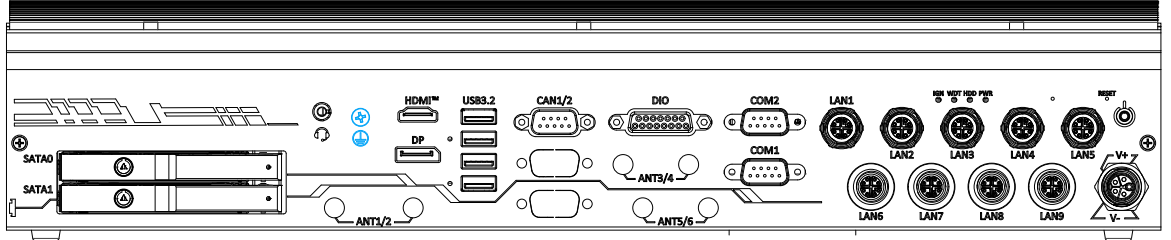

GT-92RL-H

The system offers EMI protection with an isolated PCB design. If you are powering the system using an isolated power supply, please make sure the chassis grounding point is connected. Please refer to the following instructions on grounding your device.

Before turning on the device, ground the grounding cable of the equipment. Proper grounding (grounding) is very important to protect the equipment against the harmful effects of external noise and to reduce the risk of electrocution in the event of a lightning strike. To uninstall the equipment, disconnect the ground wire after turning off the power. A ground wire is required and the part connecting the conductor must be greater than 1.0mm² or 16AWG.

Grounding Procedure for Power Source

1. Loosen the screw of the earthing point.
2. Connect the grounding cable to the ground.
3. The protection device for the power source must provide 8A current.
4. This protection device must be connected to the power source before power.
5. The cable should be 16AWG.

3.3 Installing Internal Components

3.3.1 Mini-PCle Module and Micro-SIM (3FF) Card Installation

There are two mini-PCle with SIM slots on the motherboard. Please follow the procedures below to install the mini-PCle module and SIM card, as well as the antenna for wireless communication.

1. [Removing the bottom panel.](#)
2. The mini-PCle and SIM slots are shown in the illustration below.



3. If you are installing a 5G/ 4G wireless module that requires a SIM, please install the SIM card first. Otherwise go to the next step. Push the SIM slot holder in the direction shown and flip open the holder to place the SIM into the slot.



Push the SIM holder in the direction shown



Flip open the holder and place SIM

4. Flip the holder back onto the SIM card and push in the direction shown to lock the SIM card into the slot.



5. **To install**, insert mini-PCIe module's gold finger on a 45 degree angle into the socket, gently press the module down and secure it with a screw.

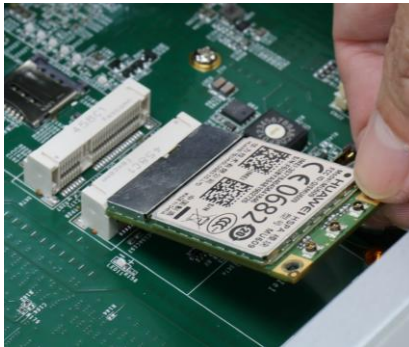

Insert on a 45 degree angle

Secure the module with a screw

6. Clip-on mini-PCIe module's antenna (please refer to the module's user manual on antenna cable connection).

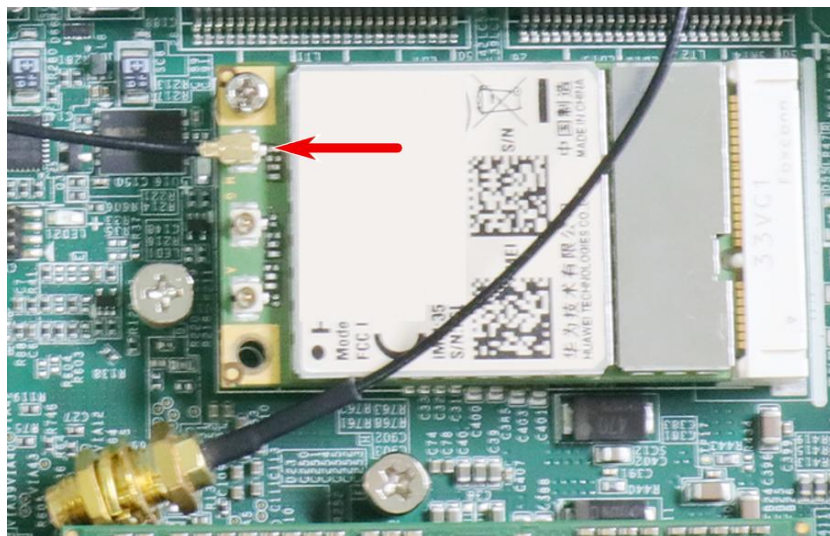

7. Remove one of the antenna covers from the enclosure.

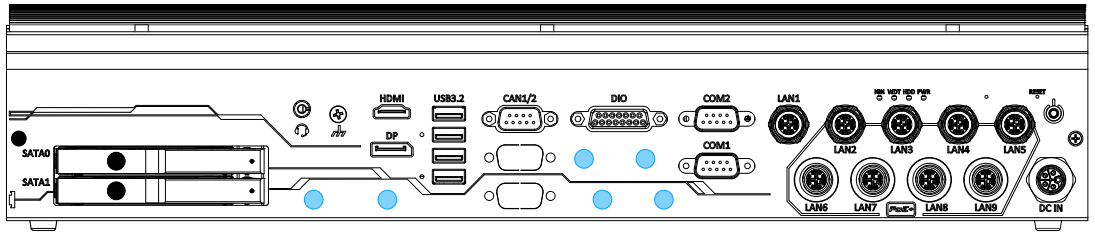

8. Secure the SMA antenna connector, and attach the external SMA antenna.

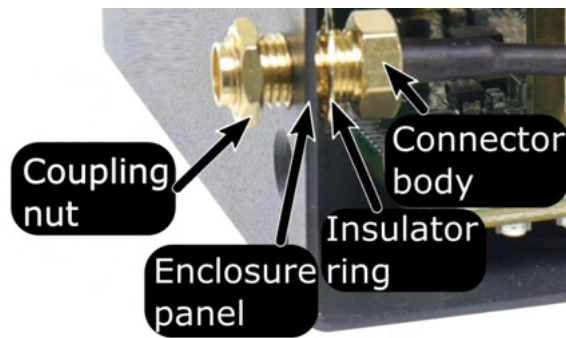

Securing antenna connection



Attach external antenna

9. [Installing the bottom panel](#) when done.
10. If you need to install other components, please refer to their respective sections.

3.3.2 M.2 2280 NVMe SSD Installation



The system has a x4 PCIe M.2 2280 slot for you to install an NVMe SSD for the ultra-fast read/ write performance. For installation, please refer to the following instructions.

1. Please refer to the section "[Removing the bottom panel](#)".
2. Once the bottom panel has been removed, locate the heat spreader shown in the illustration above. The NVMe slot is positioned underneath the heat spreader.
3. Remove the screws indicated on the heat spreader.



4. Remove the screws holding onto the heat spreader at the back of the enclosure, and remove the heat spreader.



5. Insert the module on a 45-degree angle.



6. Gently press down and secure the module with an M3 P-head screw.



7. Please remember to remove the thermal pad protector film off the heat spreader if you are installing and NVMe SSD into the system for the first.
8. Place the heat spreader back in place, and secure the four screws holding the heat spreader in place.



Screws on top of the heat spreader



Screws at the back of the enclosure

9. [Installing the bottom panel](#) when done.
10. If you need to install other components, please refer to respective sections.

3.4 Installing the Bottom panel

1. Once you have installed the internal module(s), gently place the bottom panel back onto the enclosure, and secure the panel with the screws indicated.

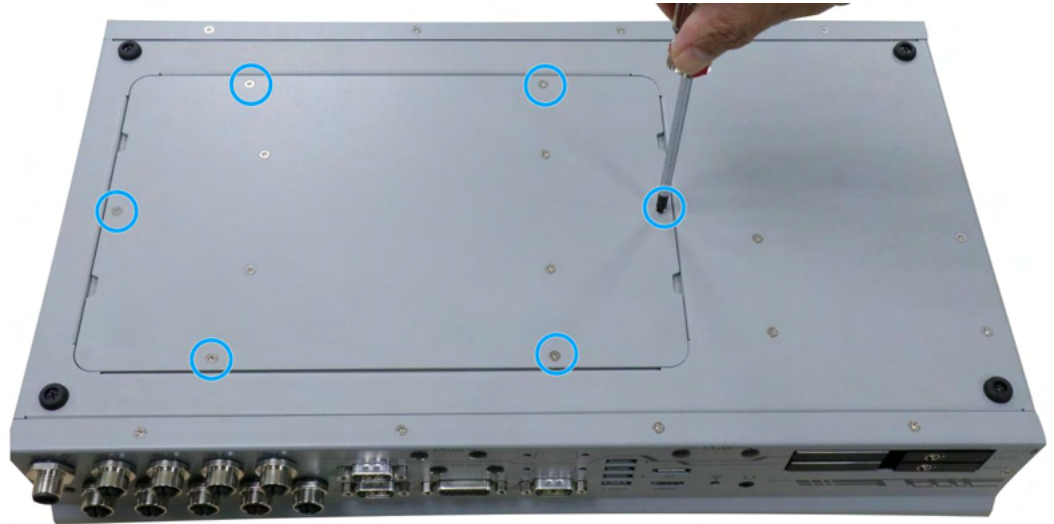

3.5 2.5" SATA HDD/ SSD Installation

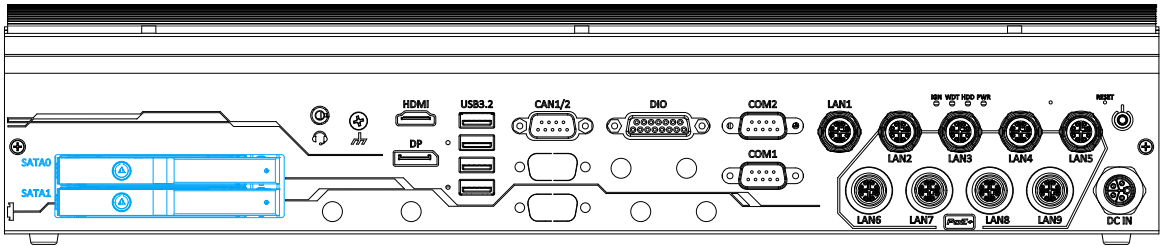

The system has two 2.5" front accessible hot-swappable trays for HDD/ SSD, supporting RAID 0/1 configurations. To install an HDD/ SSD into the tray, please refer to the following instructions:

1. Pull the lever on the 2.5" external hot-swappable slot to swing open the cover.



2. With the label side facing upward, insert the SATA connector side of the 2.5" HDD/ SSD into the slot first. You may feel resistance when the SATA connectors meet, push it in firmly until the 2.5" HDD/ SSD is fully inserted into the slot.



3. Push the lever into the 2.5" slot until it snaps into position. A key is provided (in accessory box) to lock the external slot.



Key in accessory box



2.5" HDD/ SSD slot lock

4. Repeat the steps above if you wish to install a hard drive into the other tray.

3.6 Wall-mount Bracket Installation

3.6.1 Wall-mount Bracket Installation

To install the system as a wall mount device, please refer to the following instructions.

1. Take out the **wall-mount bracket** and **M4 screws** out of the accessory box. Fix the wall-mount bracket to the both sides of the system enclosure using M4 screws. Place the system on a flat surface and secure it using **M4 screws**.

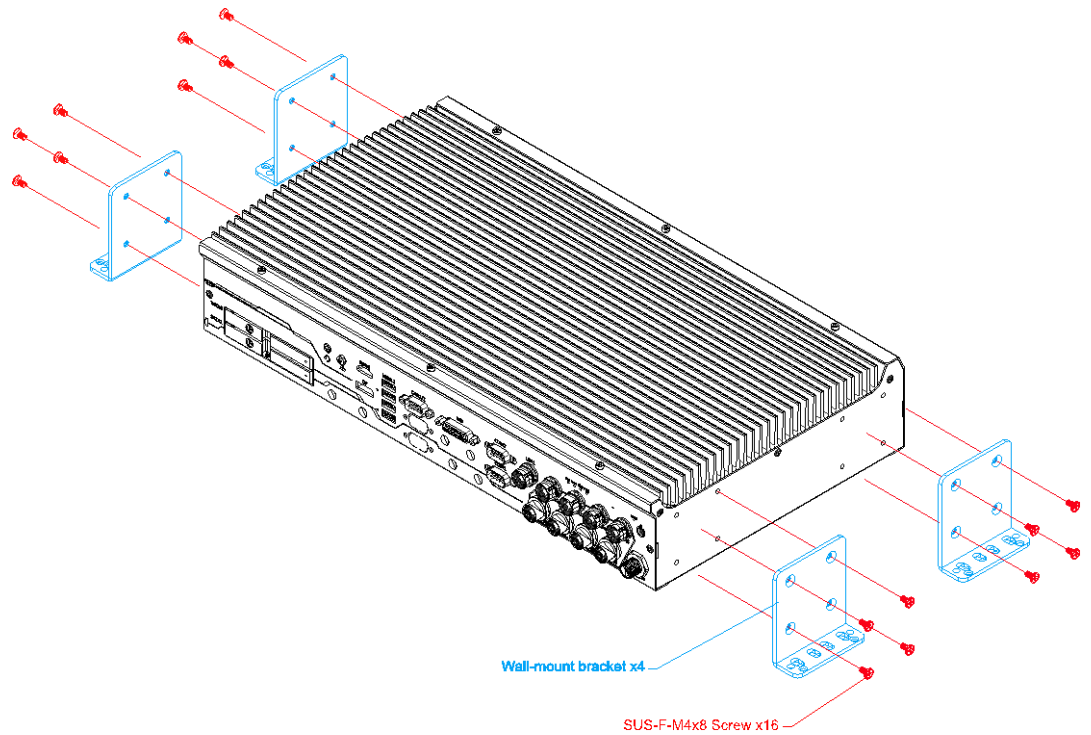

3.6.2 Rack-mount Bracket Installation

To install the system into a rack, please refer to the following instructions.

1. Take out the two **rack-mount brackets**, **handles**, **M3** and **M4 screws** out of the accessory box. Fix the **rack-mount brackets** to both sides of the system enclosure using **M4 screws**, and attach the handles to the **rack-mount brackets** using **M3 screws** to complete the rack-mount bracket installation.

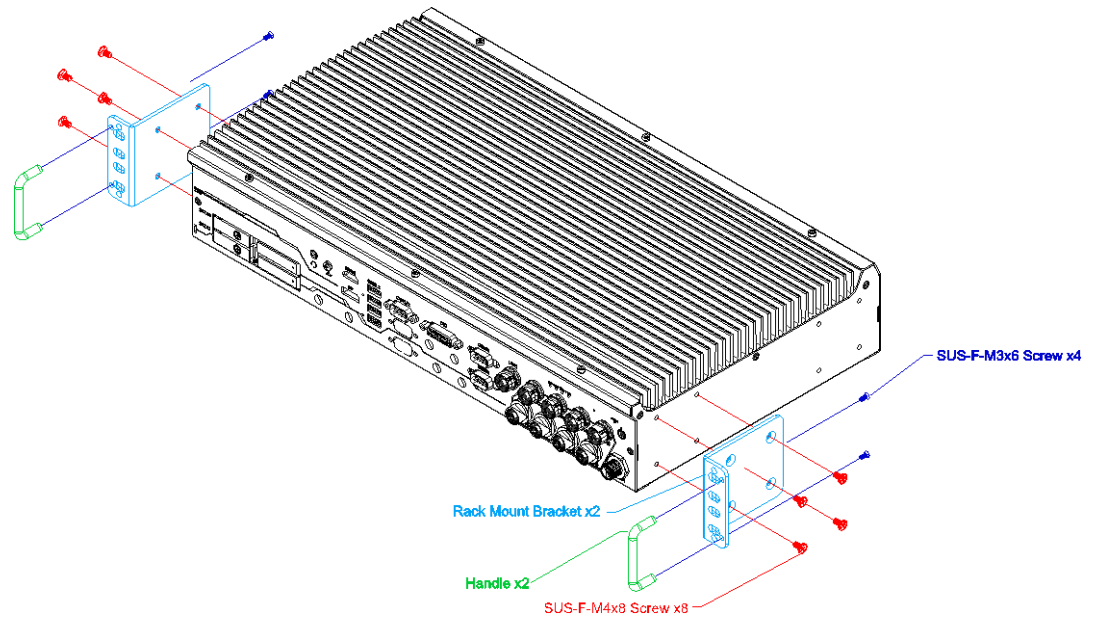

3.7 Powering On the System

There are three methods to power on the system

- Pressing the power button
- Using an external non-latched switch by connecting to the remote on/ off plug
- Sending a LAN packet via Ethernet (Wake-on-LAN)

Powering on using the [ignition power control](#) (GT-92GC only) is described in a designated section.

3.7.1 Powering On Using the Power Button

This is the simplest way to turn on your system. The power button on the front panel is a non-latched switch and behaves as the ATX-mode on/off control. With DC power connected, pushing the power button will turn on the system and the PWR LED indicator will light up. Pushing the button when system is on will turn off the system. If your operating system supports ATX power mode (i.e. Microsoft Windows or Linux), pushing the power button while the system is in operation will result in a pre-defined system behavior, such as shutdown or hibernation.

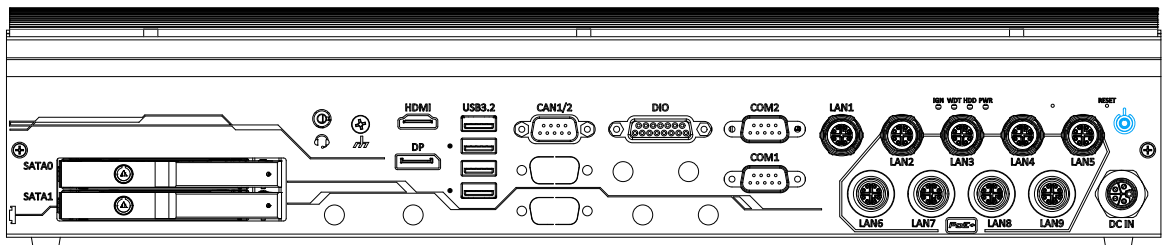

3.7.2 Powering On Using Wake-on-LAN

Wake-on-LAN (WOL) is a mechanism to wake up a computer system from a S5 (system off with standby power) state via issuing a magic packet. The system's Wake-on-LAN compatible GbE port is shown below.

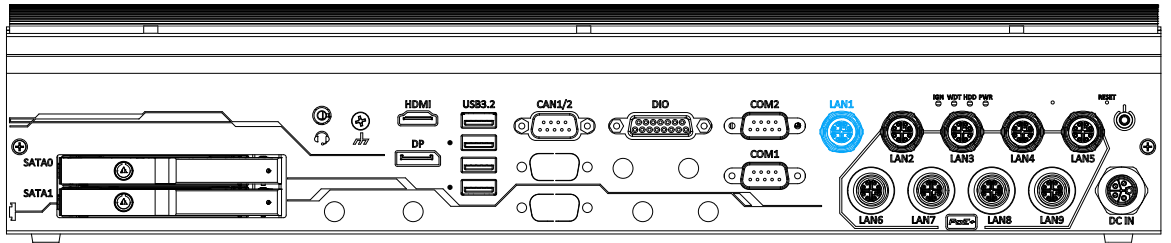

NOTE

Please make sure the Intel® chipset and Ethernet driver has been properly installed prior to setting up WOL function.

To enable WOL function, please set up WOL settings in the BIOS and in the operating system by follow the steps described below.

1. When the system boots up, press F2 to enter BIOS setup utility.
2. Go to the **[Power]>[Wake On LAN]** and set it to **[Enabled]**.
3. Press F10 to **“Save changes and exit BIOS”** and allow the system boot into the operating system.
4. Once booted into the Windows system, press **“Windows key + E”**, right-click on **“Network>Properties>Change adapter settings”**. Locate and double-click on the adapter Intel® I219 Gigabit Network Connection, click on **Configure...**
5. Click on the **Power Management** tab and check the following options. Click on OK when done.

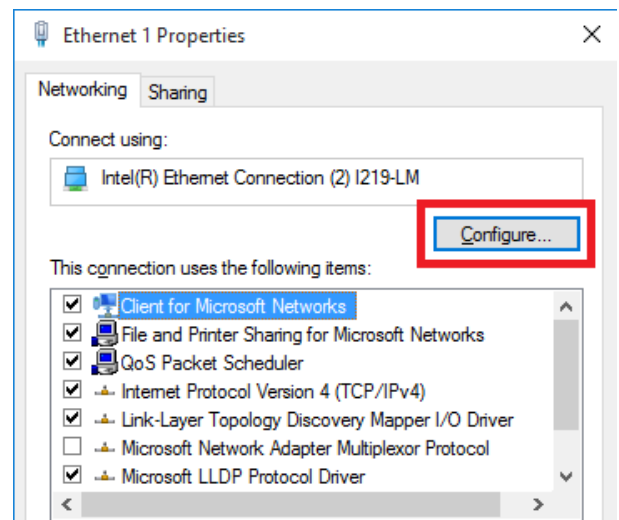

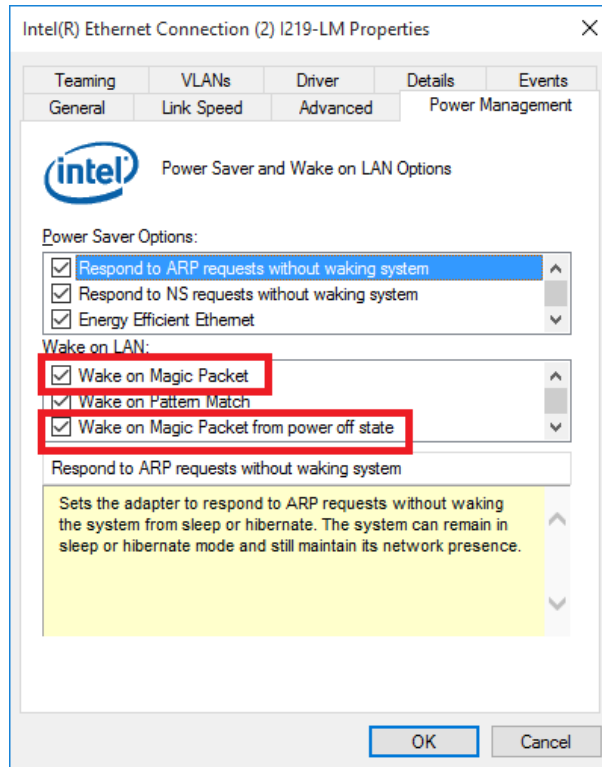

Magic Packet

The magic packet is a broadcast frame containing anywhere within its payload 6 bytes of all 255 (FF FFFFFFFF in hexadecimal), followed by sixteen repetitions of the target computer's 48-bit MAC address.

For example, NIC's 48-bit MAC Address is 78h D0h 04h 0Ah 0Bh 0Ch

```

DESTINATION SOURCE MISC
FF FFFFFFFF
78 D0 04 0A 0B 0C 78 D0 04 0A 0B 0C
78 D0 04 0A 0B 0C 78 D0 04 0A 0B 0C
78 D0 04 0A 0B 0C 78 D0 04 0A 0B 0C
78 D0 04 0A 0B 0C 78 D0 04 0A 0B 0C
78 D0 04 0A 0B 0C 78 D0 04 0A 0B 0C
78 D0 04 0A 0B 0C 78 D0 04 0A 0B 0C
78 D0 04 0A 0B 0C 78 D0 04 0A 0B 0C
78 D0 04 0A 0B 0C 78 D0 04 0A 0B 0C
78 D0 04 0A 0B 0C 78 D0 04 0A 0B 0C
MISC    CRC
    
```

There are some free tools available on Internet that can be used to send a magic packet. Please refer to the following link to understand more about [Magic Packet](#).

3.8 Ignition Power Control (GT-92GC Only)

The ignition power control module for in-vehicle applications is an MCU-based implementation that monitors the ignition signal and reacts to turn on/off the system according to predefined on/off delay. Its built-in algorithm supports other features such as ultra-low power standby, battery-low protection, system hard-off, etc. In this section, we'll illustrate the principle of ignition power control and operation modes.

3.8.1 Principles of Ignition Power Control

The basic concept of ignition power control module is to control the timing correlation between ignition signal and system power status. A typical timing correlation is described in following diagram.

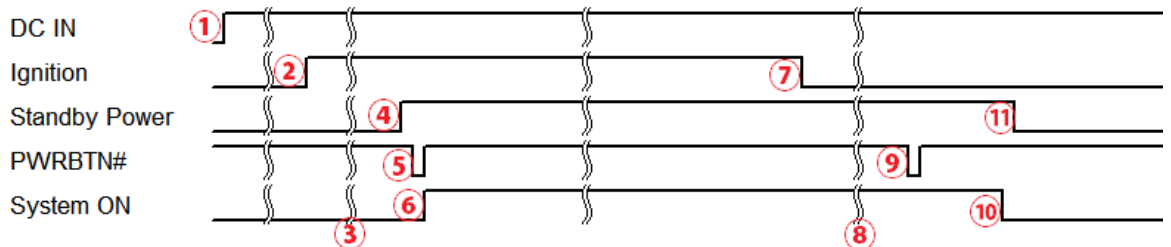

1. When DC power is supplied to the system, MCU starts to periodically detect ignition signal. Note that only MCU is working at this moment and the overall power consumption is less than 2 mW.
2. Ignition signal is active (both 12VDC and 24VDC ignition signals are accepted).
3. MCU starts to count a pre-defined power-on delay.
4. Once power-on delay expired, MCU turns on necessary standby power for the system (3.3VSB & 5VSB).
5. A PWRBTN# pulse is then issued to turn on the system (equivalent to one pressing the power button on the front panel).
6. The system is booting and becomes operational.
7. After a period of time, the ignition signal becomes inactive.
8. MCU starts to count a pre-defined power-off delay.
9. Once power-off delay expired, another PWRBTN# pulse is issued to perform a soft-off for the system (ex. a normal shutdown process for Windows system).
10. The system is completely shut down.
11. As MCU detects system is off, it turns off the standby power for the system, and operates in low power mode again (< 2mW power consumption).

3.8.2 Additional Features of Ignition Power Control

In addition to the typical timing correlation, the ignition power control module offers additional features to provide additional reliability for in-vehicle applications.

1. Low battery detection

The ignition power control module continuously monitors the voltage of DC input when the system is operational. If input voltage is less than 11V (for 12VDC input) or less than 22V (for 24VDC input) over a 60-second duration, it will shut down the system automatically.

2. Guarded power-on/ power-off delay duration

If ignition signal goes inactive during the power-on delay duration, the ignition power control module will cancel the power-on delay process and go back to idle status. Likewise, if ignition signal goes active during the power-off delay duration, the ignition power control module will cancel the power-off delay process and keep the system running.

3. System hard-off

In some cases, system may fail to shutdown via a soft-off operation due to system/ application halts. The ignition power control module offers a mechanism called "hard-off" to handle this unexpected condition. By detecting the system status, it can determine whether the system is shutting down normally. If not, the ignition power control module will force cut-off the system power 10 minutes after the power-off delay duration.

4. Smart off-delay

The ignition power control module offers two modes (mode 13 & mode 14) which have very long power-off delay duration for applications require additional off-line time to process after the vehicle has stopped. In these two modes, the ignition power control module will automatically detect the system status during the power-off delay duration. If the system has shutdown (by the application software) prior to power-off delay expiring, it will cut off the system power immediately to prevent further battery consumption.

3.8.3 Wiring Ignition Signal (GT-92GC Only)

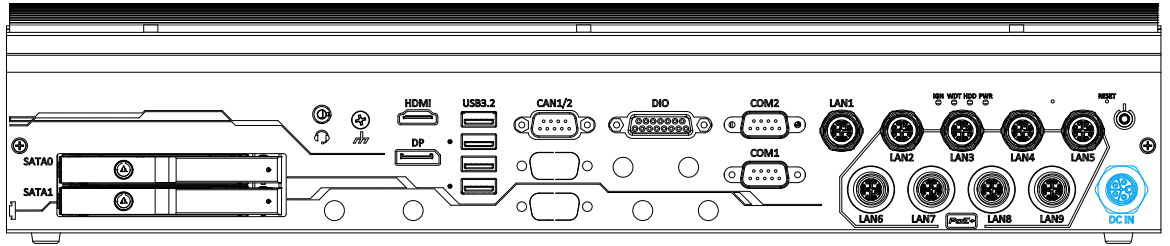

To have ignition power control for in-vehicle usage, you need to supply IGN signal to the system. The IGN input is located on the M12 L-coded connector (shared with DC power input). Below is the typical wiring configuration for in-vehicle applications.

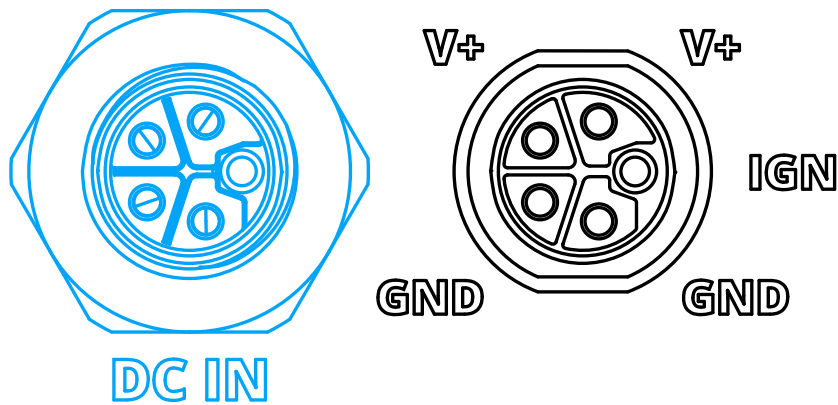

1. Connect car Battery+ line (12V for sedan, 24V for bus/truck) to V+.
2. Connect car Batter-/ GND line to GND.
3. Connect ACC line to IGN.

 **WARNING**

Please make sure your DC power source and IGN signal share the same ground.

IGN input accepts 8~48VDC. Supply a voltage higher than 48VDC may damage the system.

3.8.4 Configure your Windows system

When applying ignition power control to your system, please make sure you've configured your Windows system to initiate a shutdown process when pressing the power button. By default, Windows 10/ 11 goes to sleep (S3) mode when power button is pressed. As sleep (S3) is not a complete shutdown behavior, the ignition control function does not recognize the finish of a normal shut down process and thus users will encounter a system hard-off (power cut-off after 10 minutes). Please configure "When I press the power button" to "Shut down" in your Windows system settings.

Power button settings

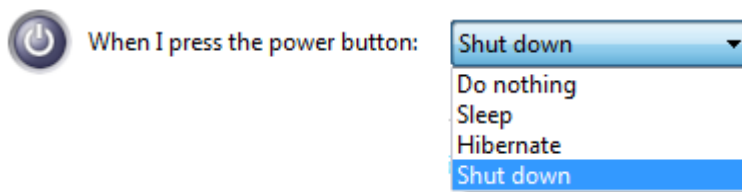

3.8.5 Operation Modes of Ignition Power Control

You can use the rotary switch to configure the operation mode. The system offers 16 (0~15) operation modes with different power-on/power-off delay configurations.



- **Mode 0**

Mode 0 is the ATX mode without power-on and power-off delay. User can only use the power button on the front panel to turn on or turn off the system.

Mode	Power-on Delay	Power-off Delay	Hard-off Timeout
0	N/A	N/A	N/A

- **Mode 1**

Mode 1 is AT mode without power-on and power-off delay. The system automatically turns on when DC power is applied. A retry mechanism is designed to repeat the power-on cycle if the system fails to boot up.

Mode	Power-on Delay	Power-off Delay	Hard-off Timeout
1	N/A	N/A	N/A

- **Mode 2**

Mode 2 is designed to have a very minor power on/ off delay of 160ms for applications that requires the system to start up almost at the same as the rest of the equipment it is working in collaboration with.

Mode	Power-on Delay	Power-off Delay	Hard-off Timeout
2	160ms	160ms	10 minutes

- **Mode 3 ~ Mode 12**

Mode 3 ~ Mode 12 have various power-on delay and power-off delay. Each mode supports a hard-off timeout of 10 minutes.

Mode	Power-on Delay	Power-off Delay	Hard-off Timeout
3	10 seconds	10 seconds	10 minutes
4	10 seconds	1 minute	10 minutes
5	10 seconds	5 minutes	10 minutes
6	30 seconds	1 minute	10 minutes
7	30 seconds	5 minutes	10 minutes
8	30 seconds	10 minutes	10 minutes
9	3 minutes	1 minute	10 minutes
10 (A)	3 minutes	10 minutes	10 minutes
11 (B)	3 minutes	30 minutes	10 minutes
12 (C)	10 minutes	30 minutes	10 minutes

- **Mode 13 (D) / Mode 14 (E)**

Mode 13 and Mode 14 are ignition power control modes with very long power-off delay. Both modes support the feature of “smart off-delay”, which automatically detect system status during power-off delay duration and cut off system power if system is off in prior to power-off delay expired.

Mode	Power-on Delay	Power-off Delay	Hard-off Timeout
13 (D)	30 seconds	2 hours	10 minutes
14 (E)	3 minutes	2 hours	10 minutes
15 (F)	Reserved		

4 System Configuration

4.1 BIOS Settings

The system is shipped with factory-default BIOS settings meticulously programmed for optimum performance and compatibility. In this section, we'll illustrate some of BIOS settings you may need to modify. Please always make sure you understand the effect of change before you proceed with any modification. If you are unsure of the function you are changing, it is recommended to change one setting at a time to see its effect(s).

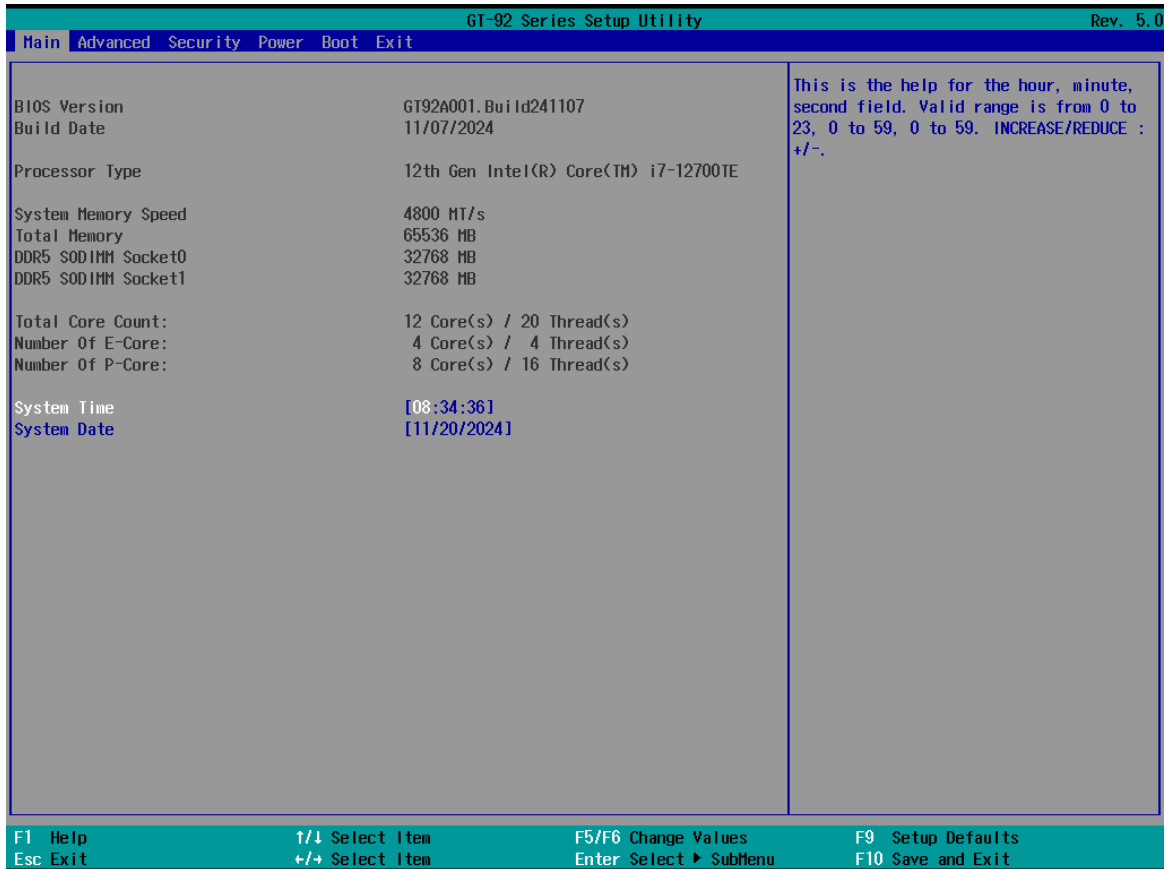

 **NOTE**

Not all BIOS settings will be discussed in this section. If a particular setting/ function you are after requires specific BIOS settings but is not discussed in this section, please contact Neusys Technical Support staff.

4.1.1 COM Port Configuration

The system's [COM1/COM2](#) ports support RS-232 (full-duplex), RS-422 (full-duplex) and RS-485 (half-duplex) mode. You can set the COM1 operating mode via BIOS settings. Another option in BIOS called “*Slew Rate*” defines how sharp the rising/falling edge is for the output signal of COM1. For long-distance RS-422/485 transmission, you may set the “*Slew Rate*” option as “High” to improve signal quality. For RS-422/485 communication, the “*RS-422/485 Termination*” option determines whether to enable/disable internal termination of RS-422/485 transceiver according to your wiring configuration (e.g. with or without external termination).

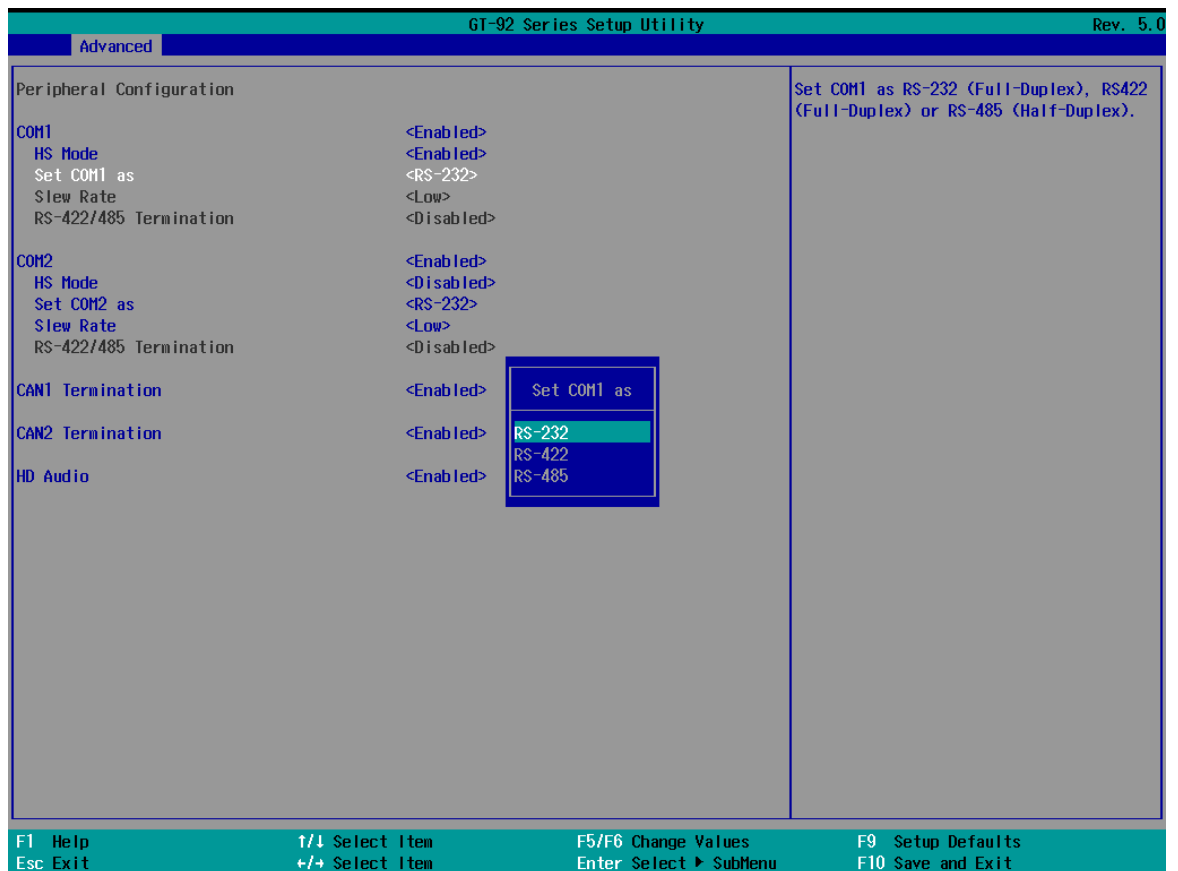

To set COM port operating mode:

1. Press **F2** when the system boots up to enter the BIOS setup utility.
2. Go to **[Advanced] > [Peripheral Configuration]**.
3. Set the **[Set COM1 Mode as]** option to the desired mode.
4. Once set, press **F10** to “Exit Saving Changes”.

4.1.2 COM Port High Speed Mode

The high speed mode of each COM port effectively allows for the port's baud rate generator to operate at 8x the speed with an effective baud rate of 921,600 bps (115,200 x 8). Please refer to the following instructions on how to enable the high speed mode for your COM port (COM1 used as an example).

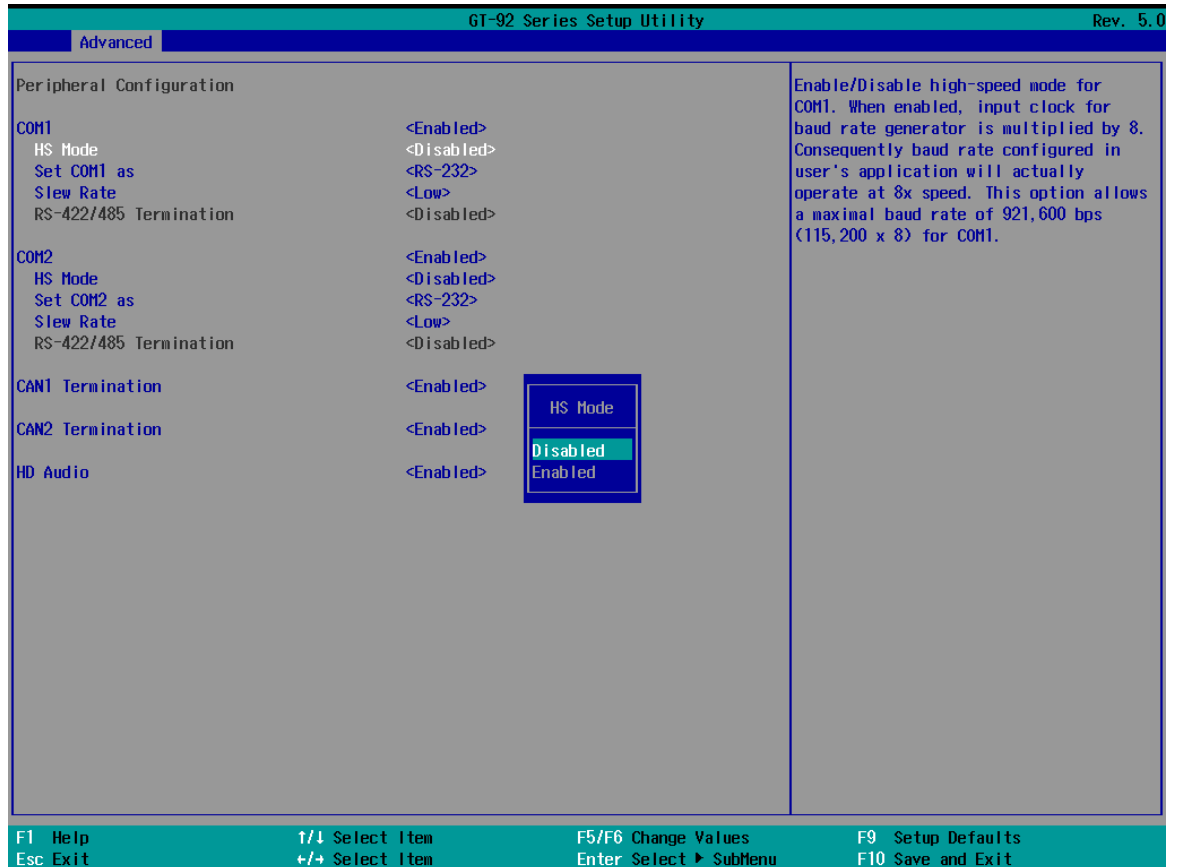

To set COM port high speed mode:

1. Press **F2** when the system boots up to enter the BIOS setup utility.
2. Go to **[Advanced] > [Peripheral Configuration]**.
3. Enable or set the **[Set COM1 Mode as]** option to the desired mode.
4. Highlight **[HS Mode]** and press ENTER to bring up options, highlight **[Enable]** and press ENTER.
5. Once set, press **F10** to "Exit Saving Changes".

4.1.3 CAN Termination

The setting controls the termination of the Controller Area Network (CAN) bus signals. Termination is used to prevent signal reflections and ensure stable communication by providing a resistance at the end of the bus. When enabled, it ensures optimal signal integrity. Disabling termination may be required in cases where the device is not located at the end of the CAN bus or when using specific network configurations. Proper termination is critical for reliable data transmission and preventing communication errors in CAN-based systems.

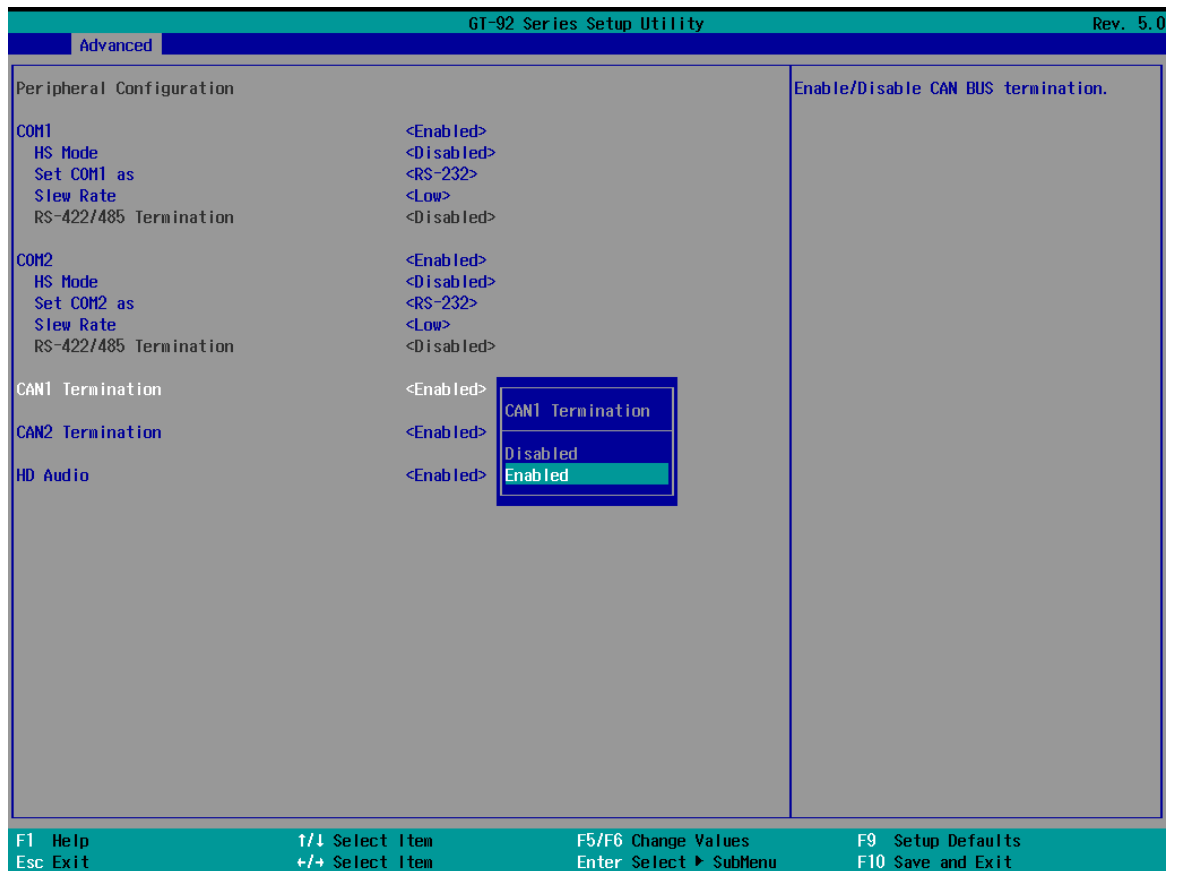

To set COM port high speed mode:

1. Press **F2** when the system boots up to enter the BIOS setup utility.
2. Go to **[Advanced] > [Peripheral Configuration]**.
3. Select CAN1 or 2 **[CAN1 termination]** and press **ENTER**.
4. Highlight **[Disabled]** or **[Enable]** and press **ENTER** make your selection.
5. Once set, press **F10** to "Exit Saving Changes".

4.1.4 CPU PCI Express Configuration

This setting offers delay in milliseconds for PEG port initialization and PCI enumeration. By increasing the delay value, it may eliminate compatibility issue(s) with some PCIe add-on cards.

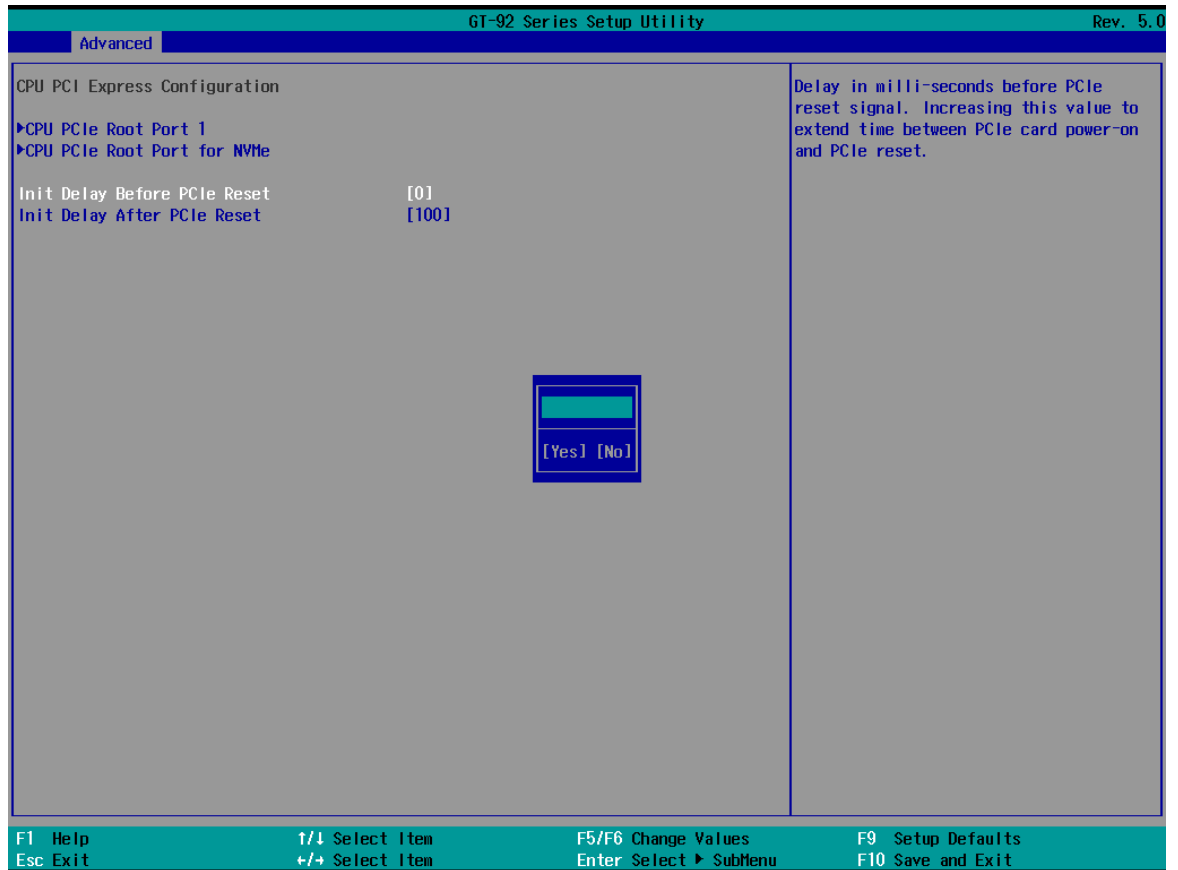

To set PEG delay in milliseconds:

1. When system boots up, press F2 to enter BIOS setup utility.
2. Go to **[Advanced] > [System Agent (SA) Configuration] > [CPU PCI Express Configuration] > [Init Delay Before PCIe Reset]** and press ENTER.
3. A small window appears and you may enter a maximum delay value of up to 30,000ms.
4. When done, press F10 to "Exit Saving Changes"

4.1.5 Volume Management Device (VMD)

Limited by the number hard drive the system can accommodate, the system supports RAID configurations in RAID 0 (striping) or RAID 1 (mirror) mode, you need to have at least two hard drives or SSDs installed. Users can select the configuration that best suit their needs with RAID 0 (striping) mode offering better hard drive read/ write performances while RAID 1 (mirror) offers better data security.



WARNING

Please back up the hard drive data before you create or modify RAID volume(s) as the process may cause irreversible data deletion. When creating a RAID volume, it is also recommended to use hard drives from the same batch (same brand, model, capacity, rpm rate, etc.) to avoid performance or capacity allocation issues.

1. When system boots up, press F2 to enter BIOS setup utility.
2. Go to **[Advanced] > [VMD Configuration]**, press ENTER.
3. Highlight **[Enable VMD controller]**, press ENTER to bring up Options, Enabled/Disabled, select Enabled and press ENTER.

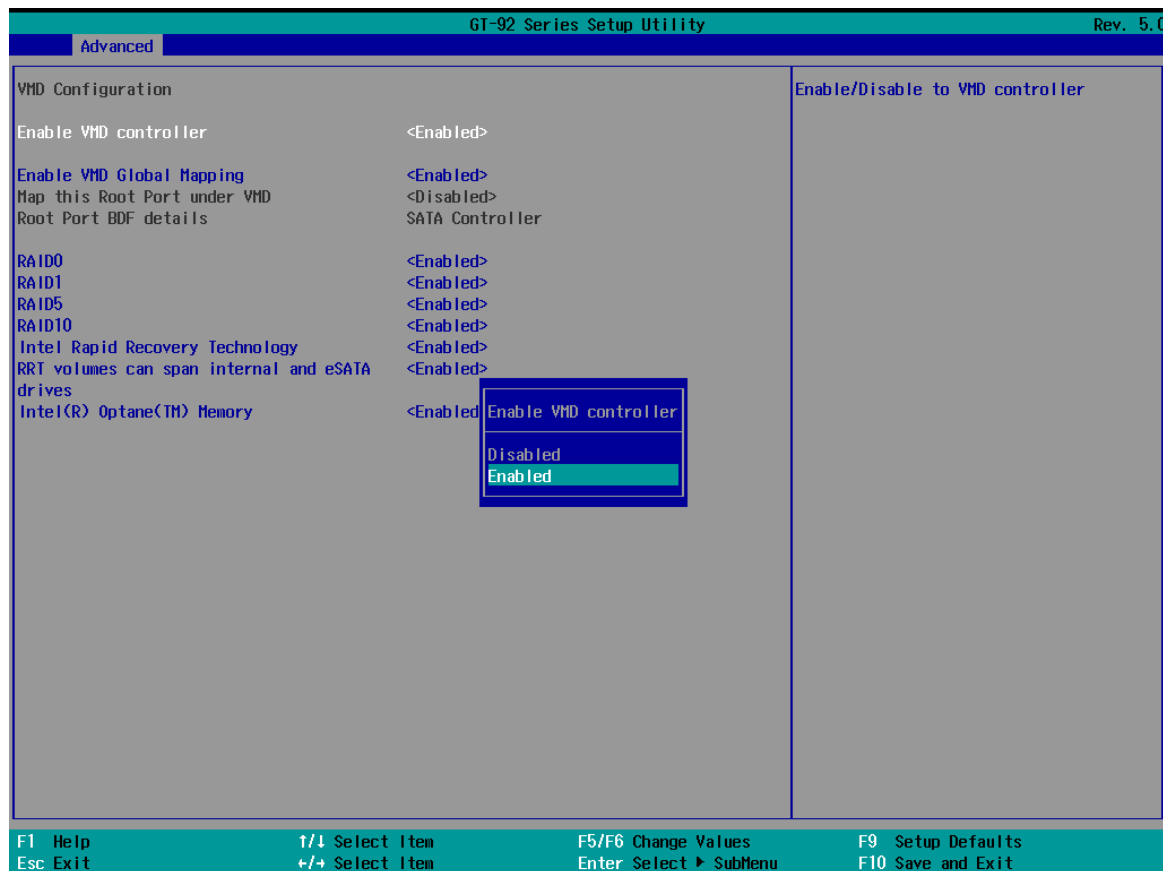

4. Highlight **[RAID0]** or **[RAID1]**, press ENTER to bring up options, Enabled/ Disabled, select your choice and press ENTER again to confirm selection.

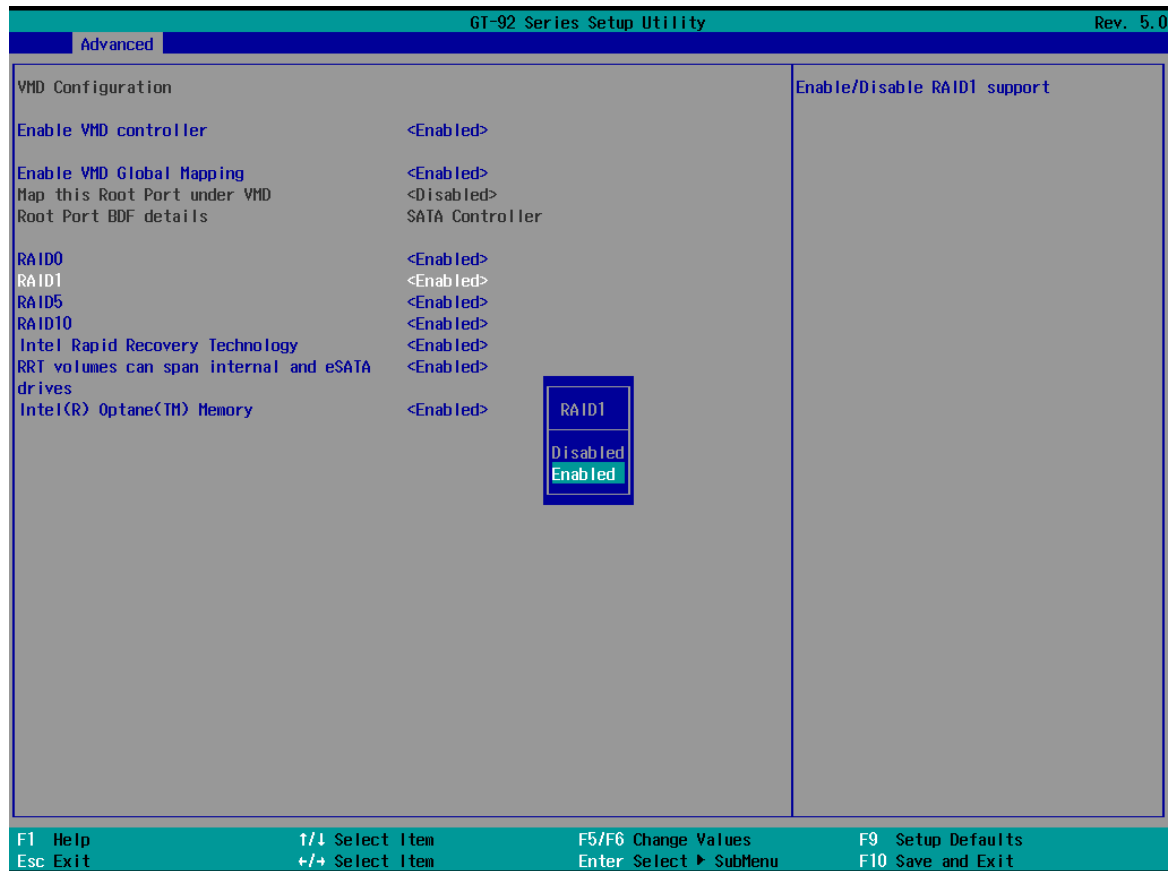

5. Highlight your selection, press Enter and press F10 to "Exit Saving Changes".

4.1.6 TPM Availability

Trusted Platform Module (TPM) is a hardware-based cryptoprocessor to secure hardware by integrating cryptographic keys into devices. The system is designed with on-board TPM 2.0 module. As TPM 2.0 requires 64-bit Windows 10 with UEFI boot mode, it is enabled in BIOS by default.

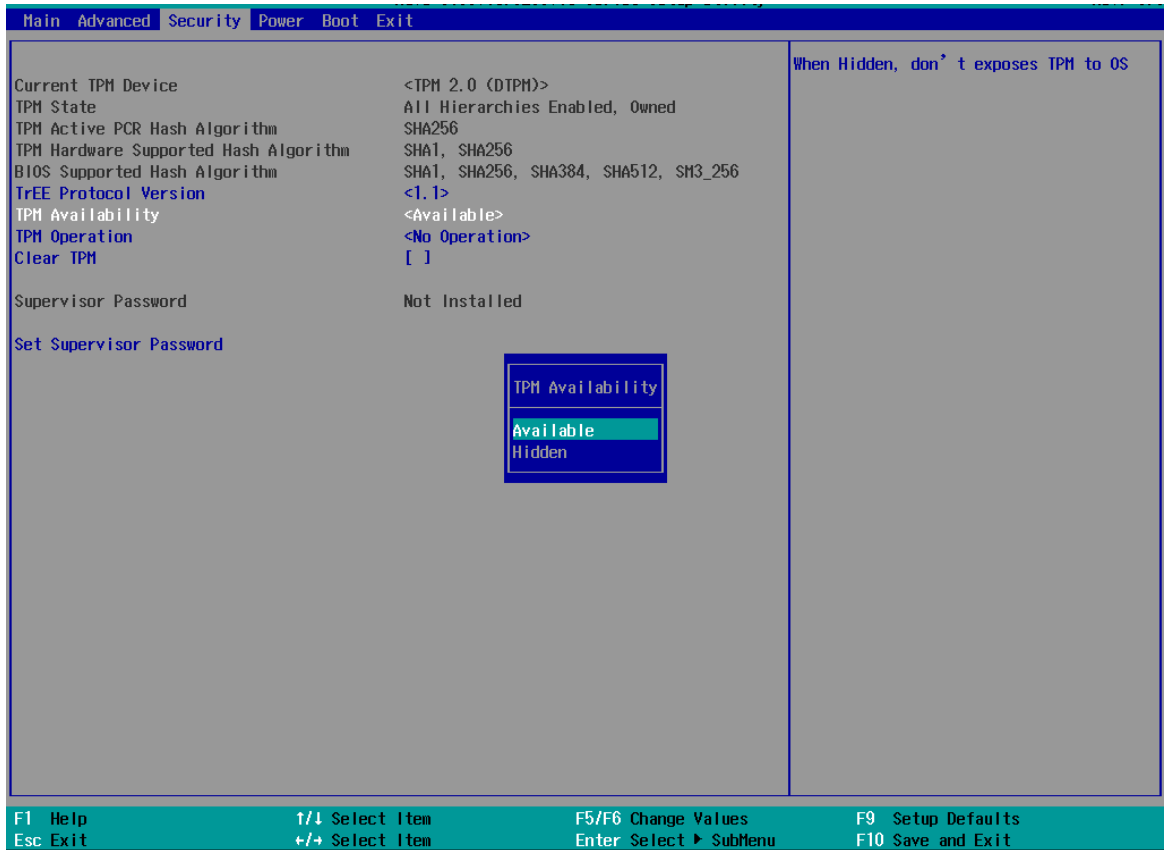

To enable TPM availability:

1. When system boots up, press F2 to enter BIOS setup utility.
2. Go to **[Security] > [TPM Availability]**, press ENTER to bring up Options, Available/Hidden.
3. Highlight your selection, press Enter and press F10 to "Exit Saving Changes".

4.1.7 Power over Ethernet (PoE) Power Enable

Power over Ethernet (PoE) supplies electrical power and data on a standard CAT-5/CAT-6 Ethernet cable. Acting as a PoE PSE (Power Sourcing Equipment), compliant with IEEE 802.3at, each PoE port delivers up to 25W to a Powered Device (PD). The system has a total 100W power budget. The PoE power can be Enabled/ Disabled in the BIOS.

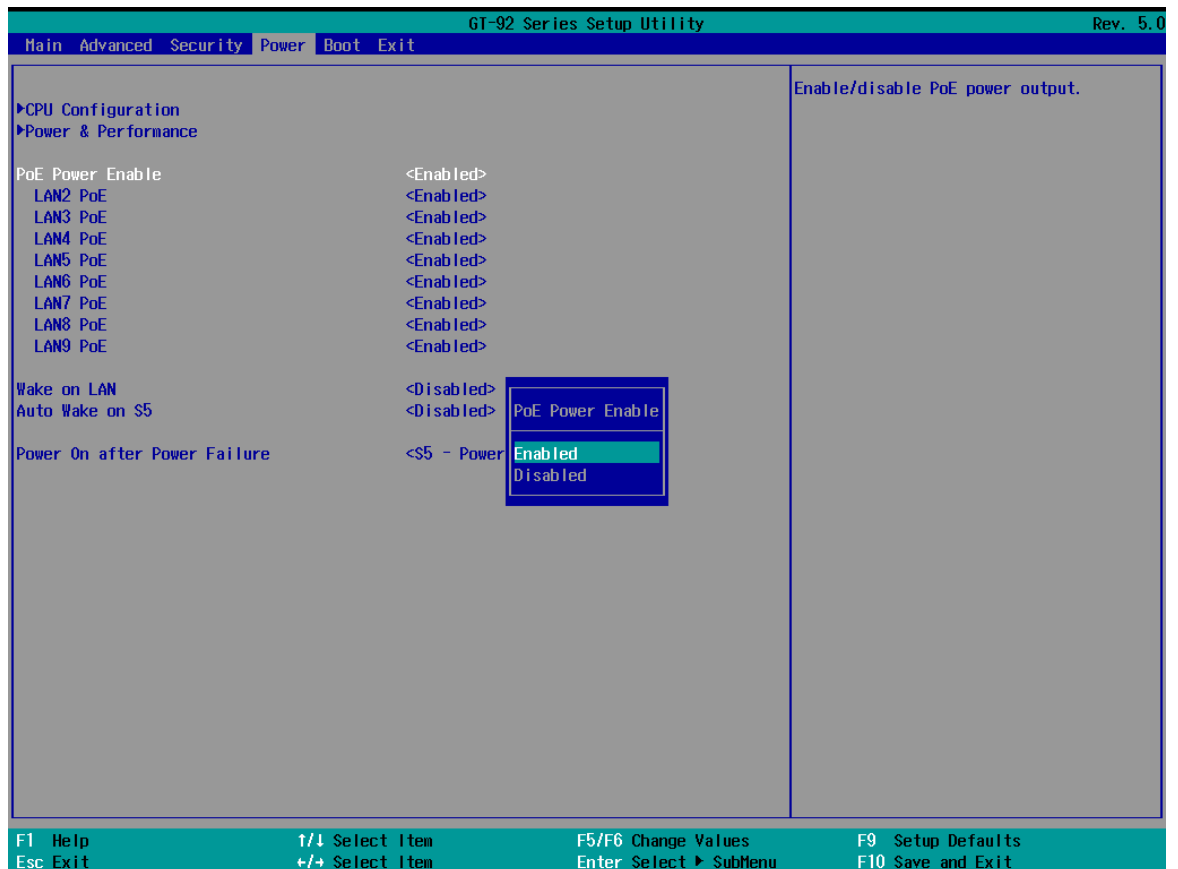

To enable/ disable “PoE Power Enable” option:

1. When system boots up, press F2 to enter BIOS setup utility.
2. Go to **[Power] > [PoE Power Enable]**.
3. Press ENTER to bring up setting options, scroll to the setting (Enabled/ Disabled) you desire and press ENTER to set.

- You can also enable/ disable each port, individually. Use the arrow key to highlight the port, press ENTER to bring up options (Enabled/ Disabled), press ENTER again to select the option.

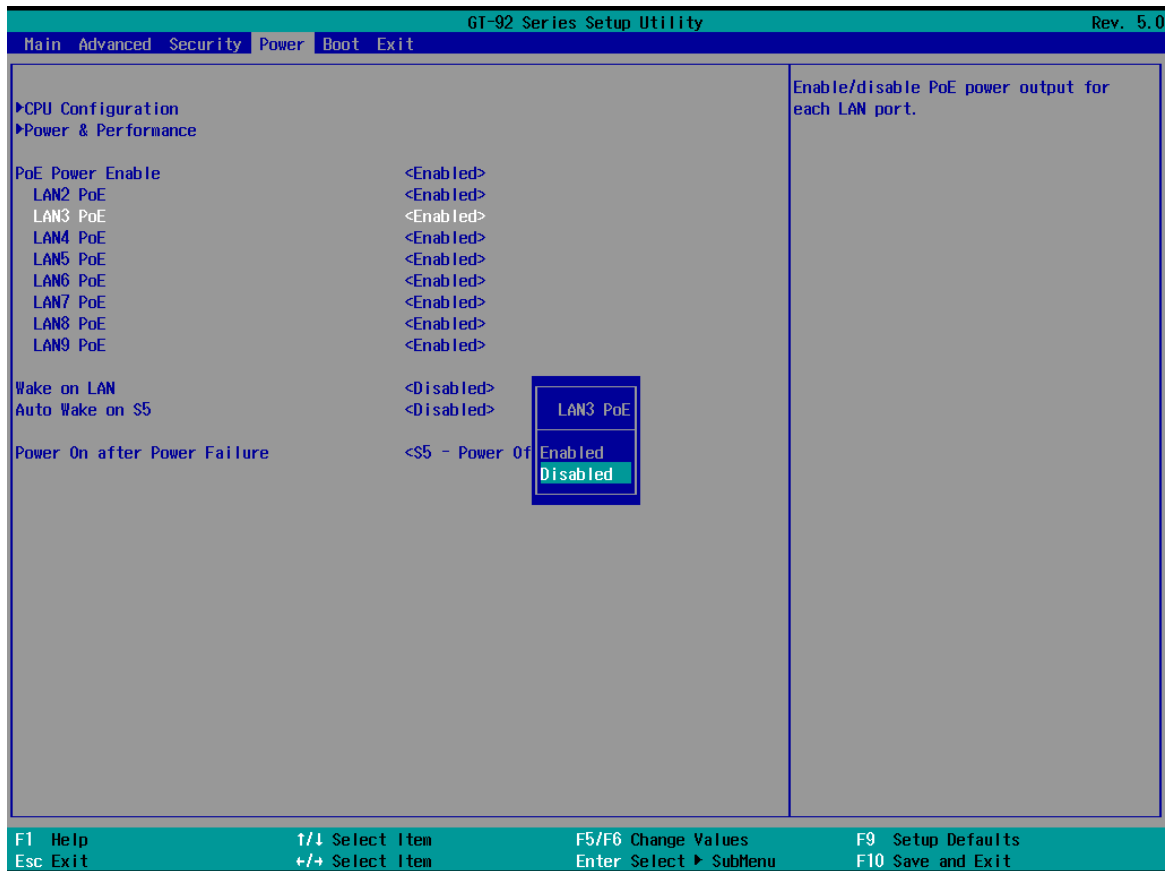
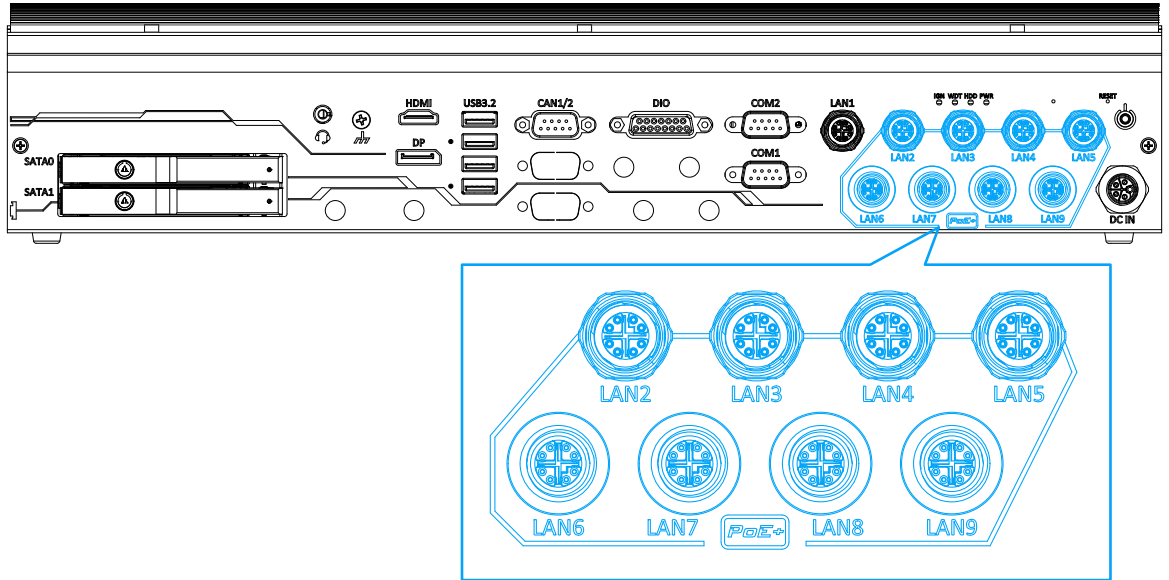

- Press F10 to “Exit Saving Changes”.

4.1.8 Auto Wake on S5

When the system is set to operate in S5 state, the user can specify a time to turn on the system, daily or monthly.

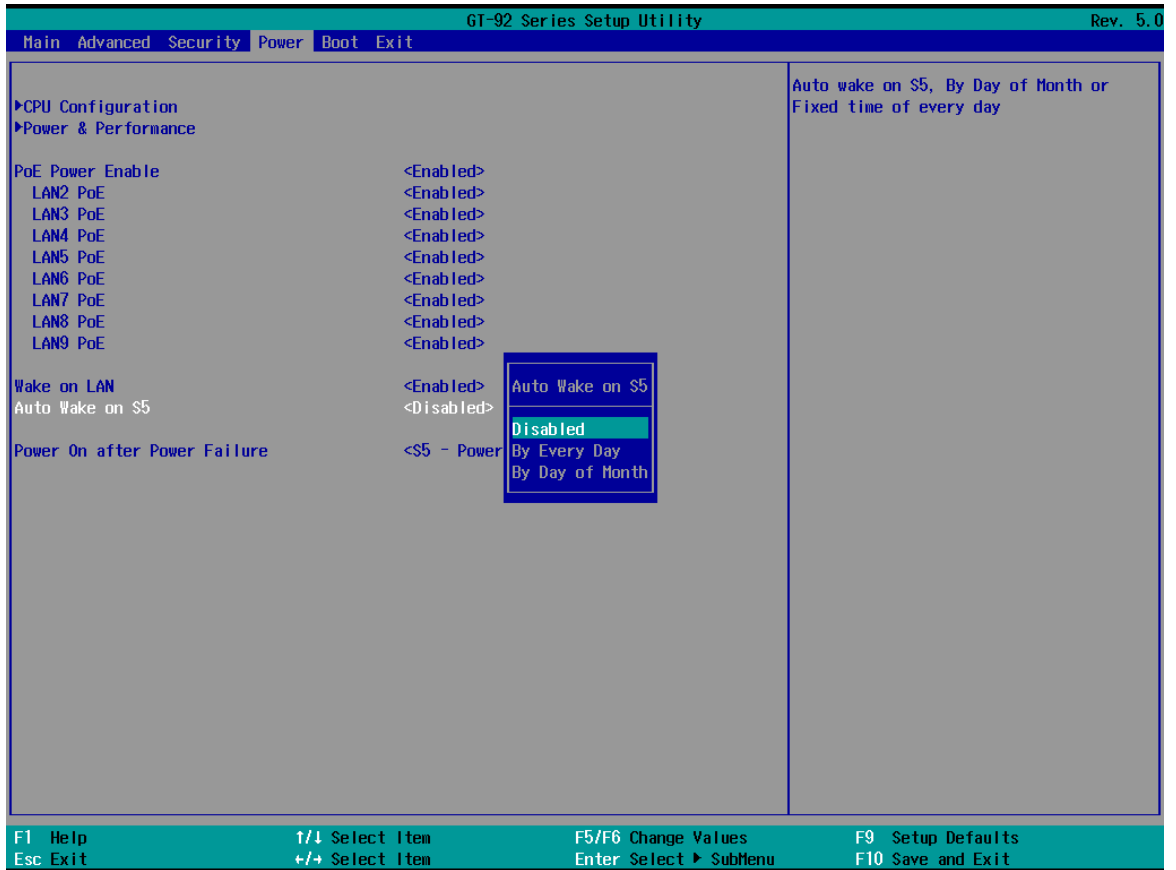

Value	Option	Description
Auto Wake on S5	Disabled	The system does not turn on when operating in state S5.
	By Every Day	The system turns on each day when operating in state S5. Specify the time of day.
	By Day of Month	The system turns on each month when operating in state S5. Specify the day and time.

Highlight your selection, press ENTER and press F10 to “Exit Saving Changes”.

4.1.9 Power On After Power Failure Option

This option defines the behavior of your system when DC power is supplied.

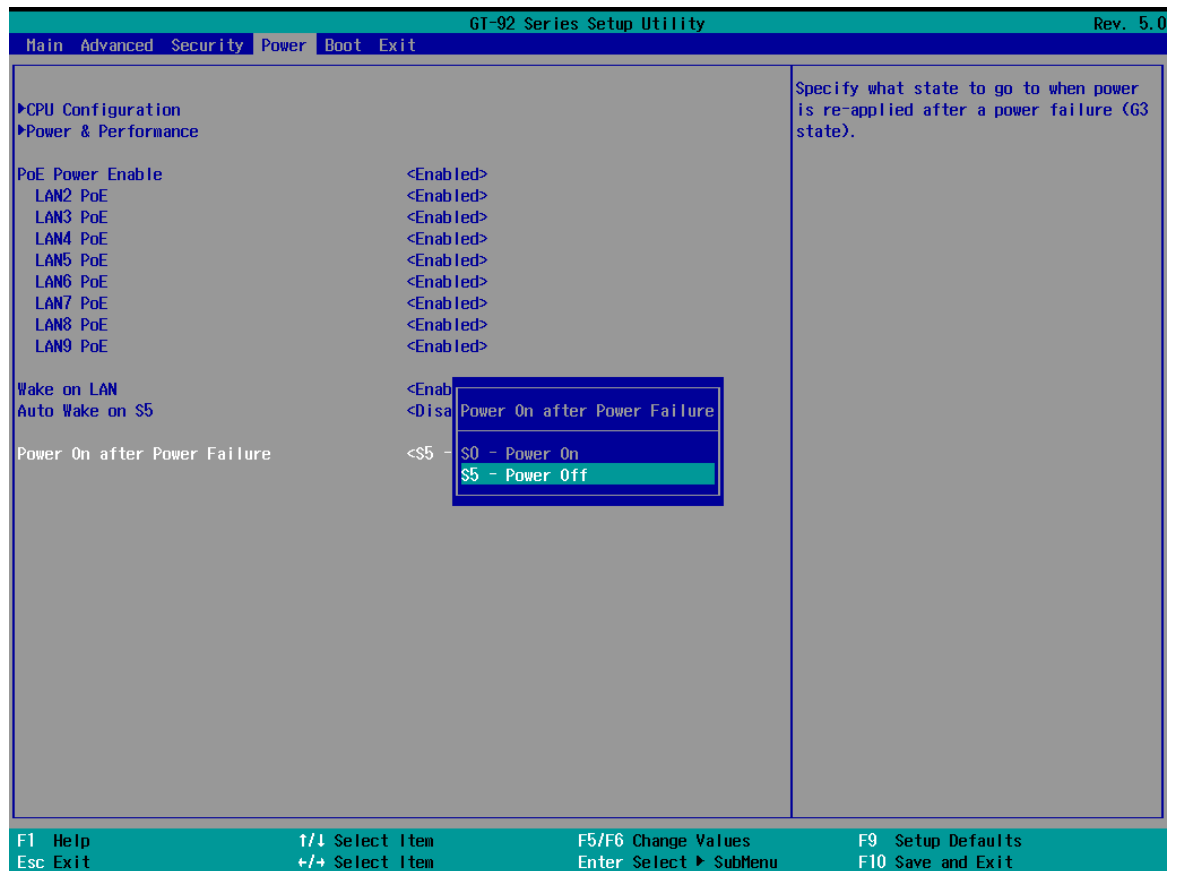

Value	Description
S0 – Power On	System is powered on when DC power is supplied.
S5 – Power Off	System is kept in off state when DC power is supplied.

To set “Power On after Power Failure” option:

1. When system boots up, press F2 to enter BIOS setup utility.
2. Go to **[Power] > [Power On after Power Failure]**.
3. Scroll down to highlight **[Power On after Power Failure]**, press ENTER to bring up setting options, S0 – Power On or S5 – Power Off, and press ENTER to select the setting.
4. Press F10 to “Exit Saving Changes”.

4.1.10 Power & Performance (CPU SKU Power Configuration)

The system supports Intel 14th/ 13th/ 12th Gen LGA 1700 CPUs from 35W to 65W TDP. A unique feature, “**SKU Power Config**” is implemented in BIOS to allow users to specific user-defined SKU power limit. Although the system is designed to have best thermal performance with CPUs of 35W TDP, you can install a 65W CPU and limit its SKU power (to 35W) to obtain more computing power. This feature gives you the flexibility of CPU selection and great balance between computing power and operating temperature range.

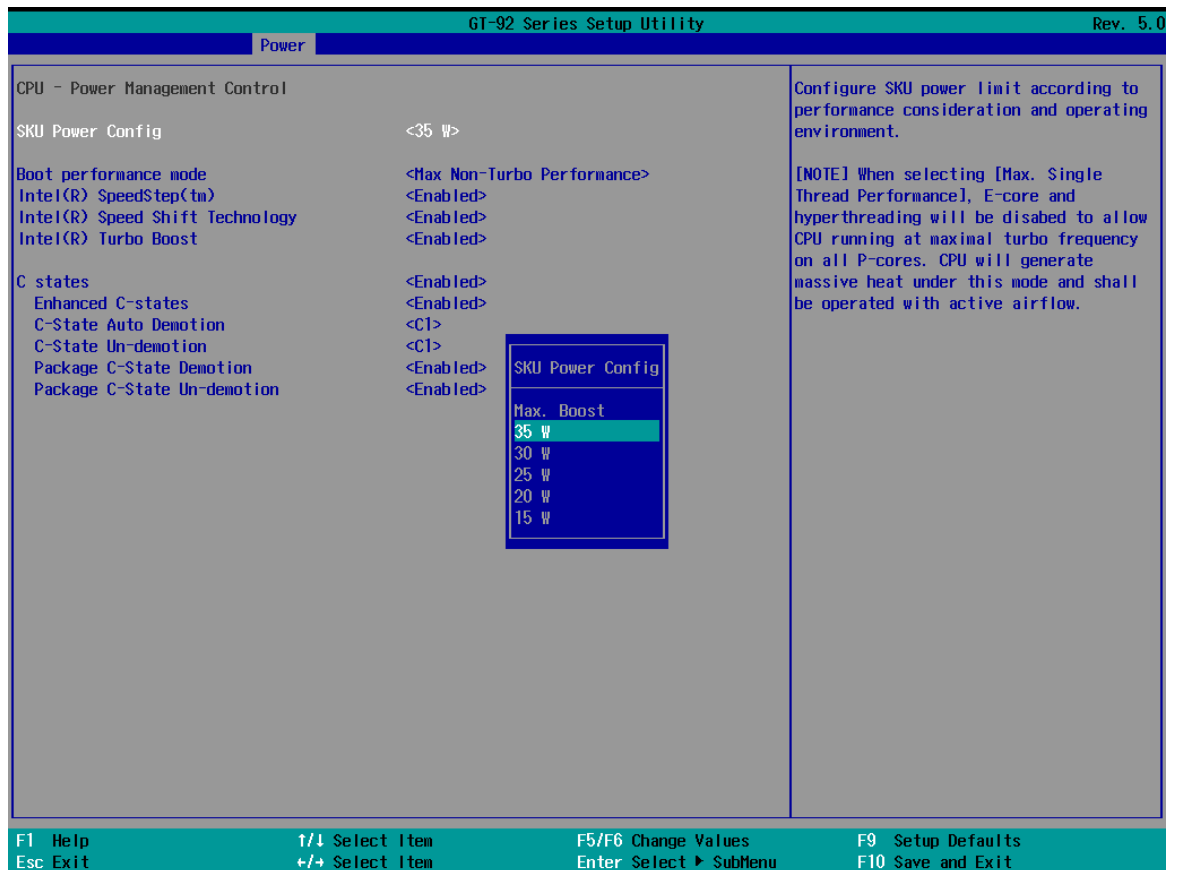

To configure the CPU SKU power limit:

1. When the system boots up, press F2 to enter BIOS setup utility.
2. Go to **[Power]** → **[Power & Performance]** → **[Power Management Control]**.
3. Select a proper value of SKU power limit for **[SKU Power Config]** option.
4. Press F10 to “Exit Saving Changes”.



NOTE

The option "Max. Boost" unleashes the CPU's maximum performance with the highest power consumption. Make sure you're using a power supply with a rated power output four times that of the CPU TDP to ensure reliable system operations.

4.1.11 Wake on LAN Option

Wake-on-LAN (WOL) is a mechanism which allows you to turn on your system via the Ethernet connection. To utilize Wake-on-LAN function, you have to enable this option first in BIOS settings. Please refer "[Powering On Using Wake-on-LAN](#)" to set up the system.

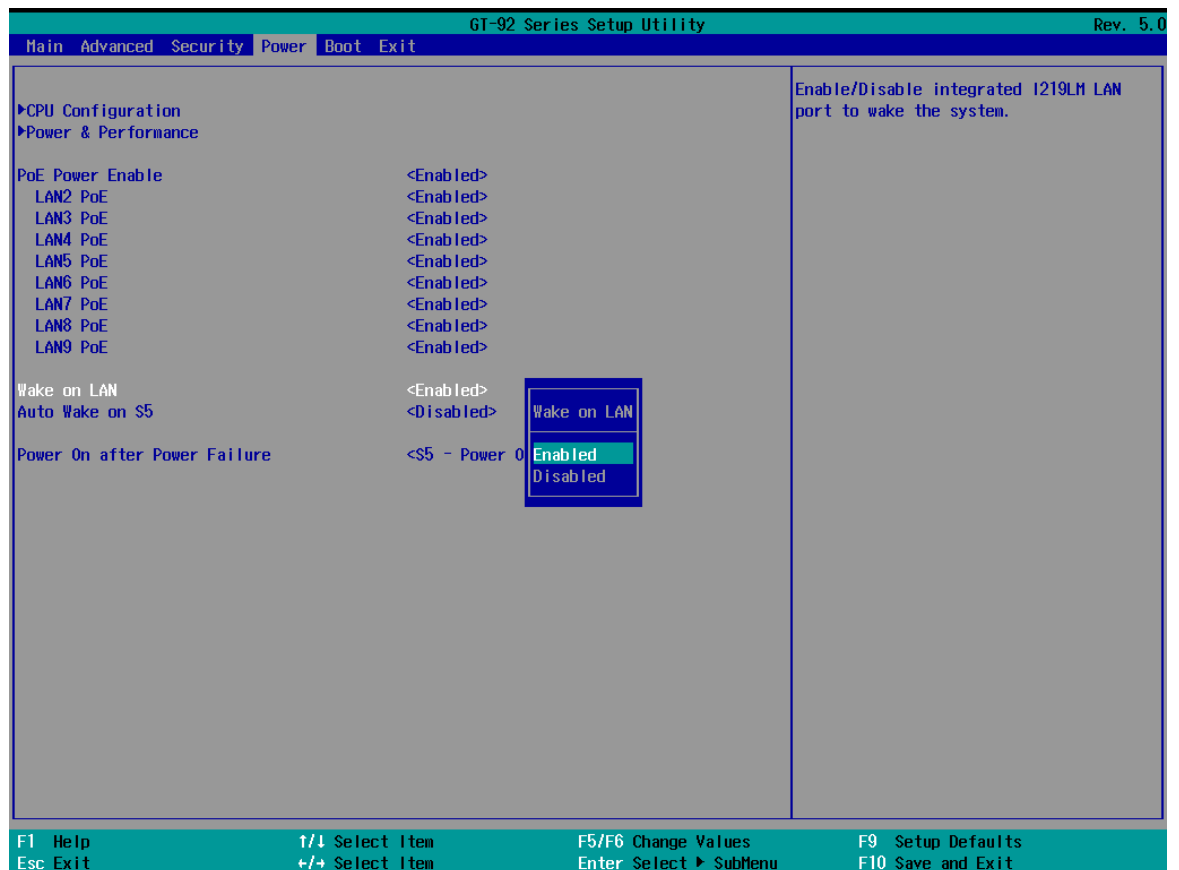

To enable/ disable “Wake on LAN” option:

1. When system boots up, press F2 to enter BIOS setup utility.
2. Go to **[Power] > [Wake on LAN]**.
3. Press ENTER to bring up setting options, scroll to the setting you desire and press Enter to set.
4. Press F10 to “Exit Saving Changes”.

4.1.12 Boot Menu

The Boot menu in BIOS allows you to specify the system’s boot characteristics by setting bootable device components (boot media) and method. Or, you may press F12 upon system start up and select a device you wish boot from.



Value	Option	Description
Boot Type	UEFI Boot Type	Only UEFI boot media listed are approved as boot media.
Quick Boot	Enabled	The system starts up faster because BIOS skips various hardware function tests
	Disabled	The system starts up slower because BIOS goes through various hardware functions tests
Quiet Boot	Enabled	During the boot up sequence, the system will display full screen logo and not show the motherboard POST messages.
	Disabled	During the boot up sequence, the system will display the motherboard POST messages.
Network Stack	Enabled	The system is available for network access using UEFI.

	Disabled	The system is not available for network access using UEFI.
PXE Boot capability	Disabled	Only UEFI Network Stack is supported: Preboot eXecution Environment (PXE) is not supported
	Enabled	By enabling the PXE boot, one can choose to boot via I219 Only .
Add Boot Options	First	Newly detected boot media are placed at the top of the boot order.
	Last	Newly detected boot media are placed at the bottom of the boot order.
ACPI Selection	1.0B/ 3.0/ 4.0/ 5.0/ 6.0	Advanced Configuration and Power Interface allows the operating system to control system power management
USB Boot	Enabled	Allow boot from bootable USB devices.
	Disabled	Does not allow boot from bootable USB devices
Timeout	1, 2, 3, etc (in seconds)	Boot delay time in seconds to give the user time to activate the hotkey to access the BIOS
Automatic Failover	Enabled	Automatically checks for the next bootable device when the set default device fails.
	Disabled	Will only boot from the designated device.
WDT for booting	Disabled, 1, 3, 5, 10 (minutes)	WDT ensures a successful system boot by specifying a timeout value

4.1.13 Add Boot Options (Position New Boot Device)

The “Add Boot Options” allow you to determine whether a newly added device (eg. USB flash disk) is to boot as the first device to boot or the last in the boot sequence.

To set the newly-installed boot device as the first or last boot device:

1. Press **F2** when the system boots up to enter the BIOS setup utility.
2. Go to **[Boot] > [Add Boot Options]** menu.
3. Select **[First]** or **[Last]** for your newly-added boot device and press ENTER.

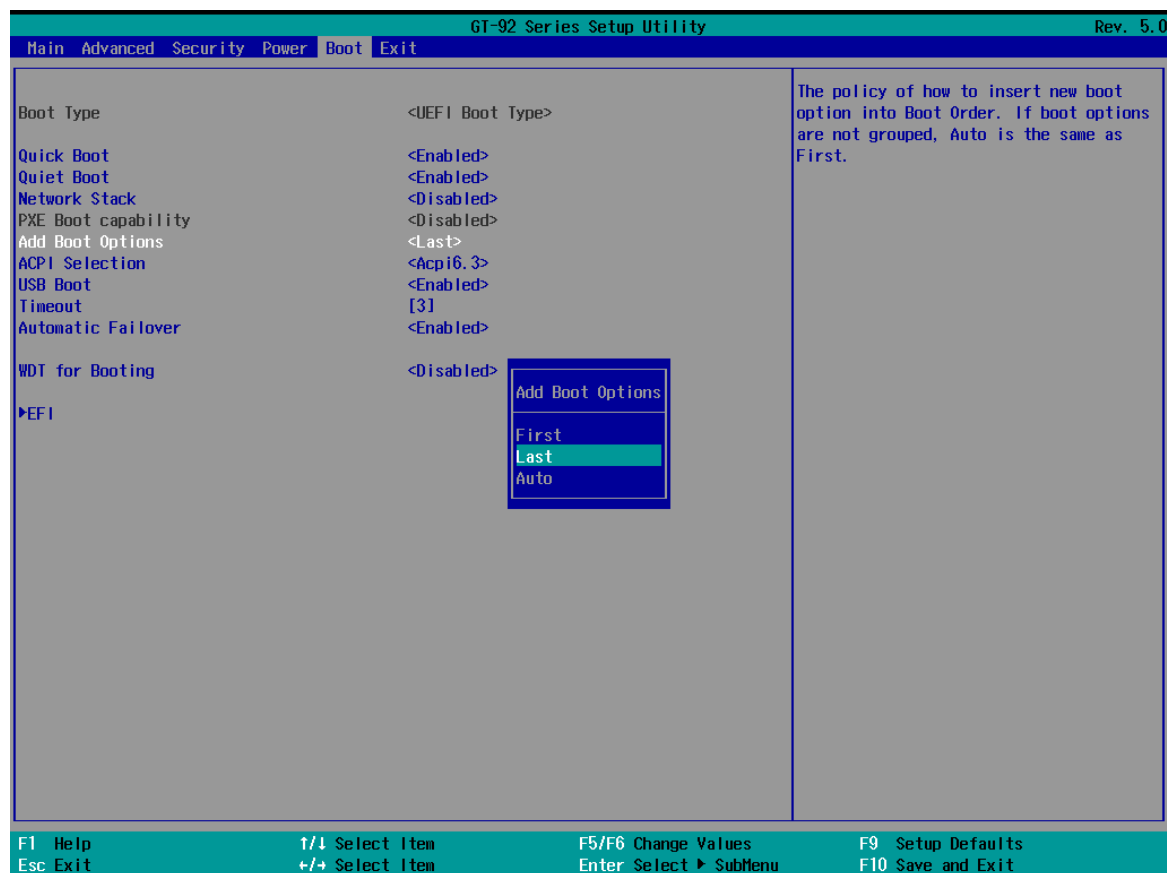

4. Once set, press **F10** to “Exit Saving Changes”.

4.1.14 Watchdog Timer for Booting

The watchdog timer secures the boot process by means of a timer. Once the timer expires, a reset command is issued to initiate another booting process. There are two options in BIOS menu, “*Automatically after POST*” and “*Manually after Entering OS*”. When “*Automatically after POST*” is selected, the BIOS automatically stops the watchdog timer after POST (Power-On Self Test) OK. When “*Manually after Entering OS*” is selected, the user must stop the watchdog timer once booted into the OS. This guarantees the system can always boot into the OS, otherwise another booting process will be initiated. For information about programming watchdog timer, please refer to [Watchdog Timer & Isolated DIO](#).

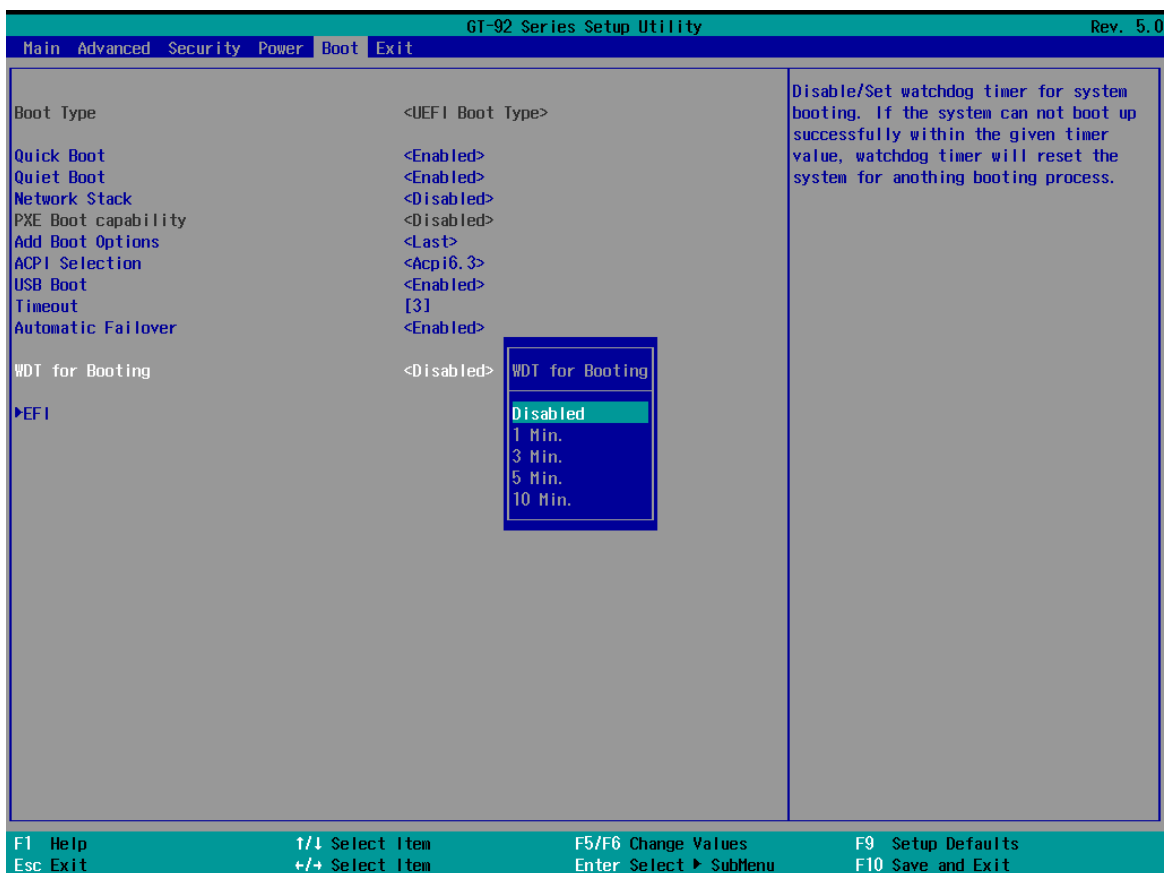

To set the watchdog timer for boot in BIOS:

1. When system boots up, press F2 to enter BIOS setup utility.
2. Go to **[Boot]** menu.
3. Disable or select timeout value for **[WDT for Booting]** option.
4. Once you give a timeout value, the **[WDT Stop Option]** option appears. You can select “*Automatically after POST*” or “*Manually after Entering OS*”.
5. Press F10 to “Exit Saving Changes”.

- When entering MEBx for the first time, it will ask for the default (old) password. Please type “admin” and press ENTER.



- The system will then request that you enter a new password. The new password must consist of at least one 7-bit ASCII non alpha-numeric character, above 32 (eg,!, @, \$) and 8 to 32 characters long. Note that under score “_” is considered an alpha-numeric character.



- After typing your new password, it will bring you to the MEBx settings page. For more MEBx configuration details, please refer to [Intel® MEBX User Guide](#).



4.3 RAID Configuration

To set up a RAID 0 or 1 volume, you need to have at least two hard drives or SSDs installed. The system supports RAID configurations in RAID 0 (striping) or RAID 1 (mirror) mode. Users can select the configuration that best suit their needs with RAID 0 (striping) mode offering better hard drive read/ write performances while RAID 1 (mirror) offers better data security.



WARNING

Please back up the hard drive data before you create or modify RAID volume(s) as the process may cause irreversible data deletion. When creating a RAID volume, it is also recommended to use hard drives from the same batch (same brand, model, capacity, rpm rate, etc.) to avoid performance or capacity allocation issues.

4.3.1 Enabling Volume Management Device (VMD) for RAID Volume Setup

1. When system boots up, press F2 to enter BIOS setup utility.
2. Go to **[Advanced]** > **[System Agent (SA) Configuration]** > **[VMD setup menu]**, and press ENTER.
3. Select **[Enable VMD controller]** and press ENTER, highlight **[Enabled]** and press ENTER.

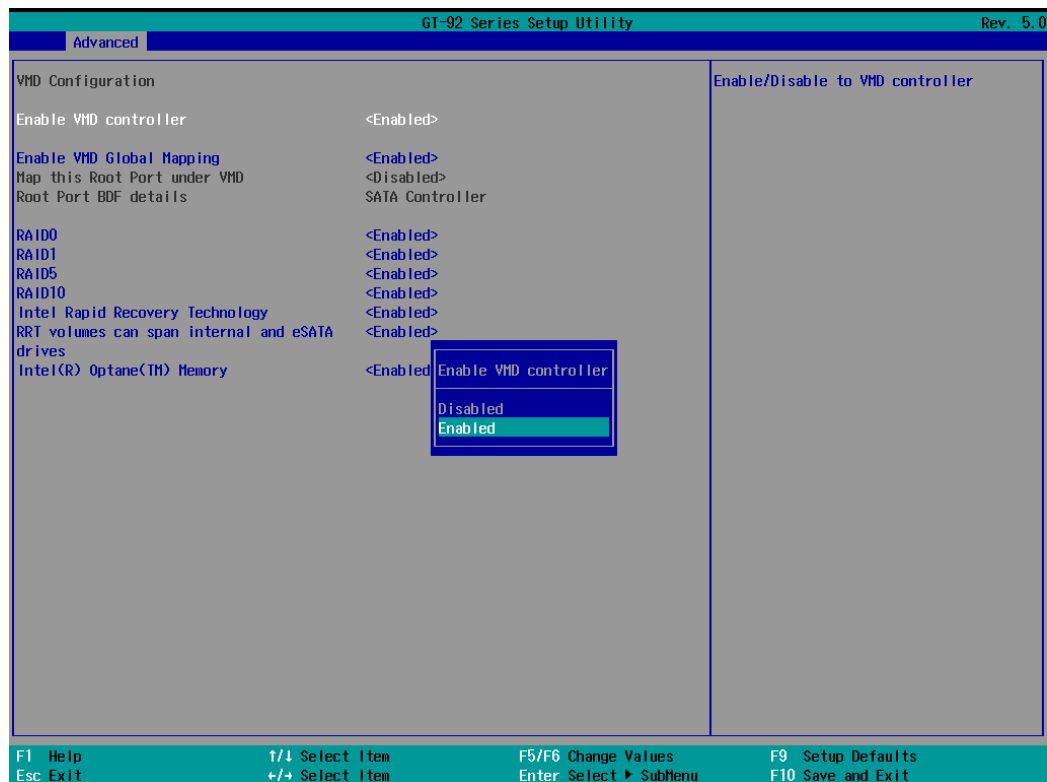

4. Press F10 to “Exit Saving Changes” and reboot the system.
5. When the system reboots, press **[F3]** to enter the Device Manager configuration utility.

4.3.2 RAID Volume Setup

1. Once you've press F3 upon system boot up and you are in the Device Manager configuration utility, select **[Intel® Rapid Storage Technology]** and press ENTER.

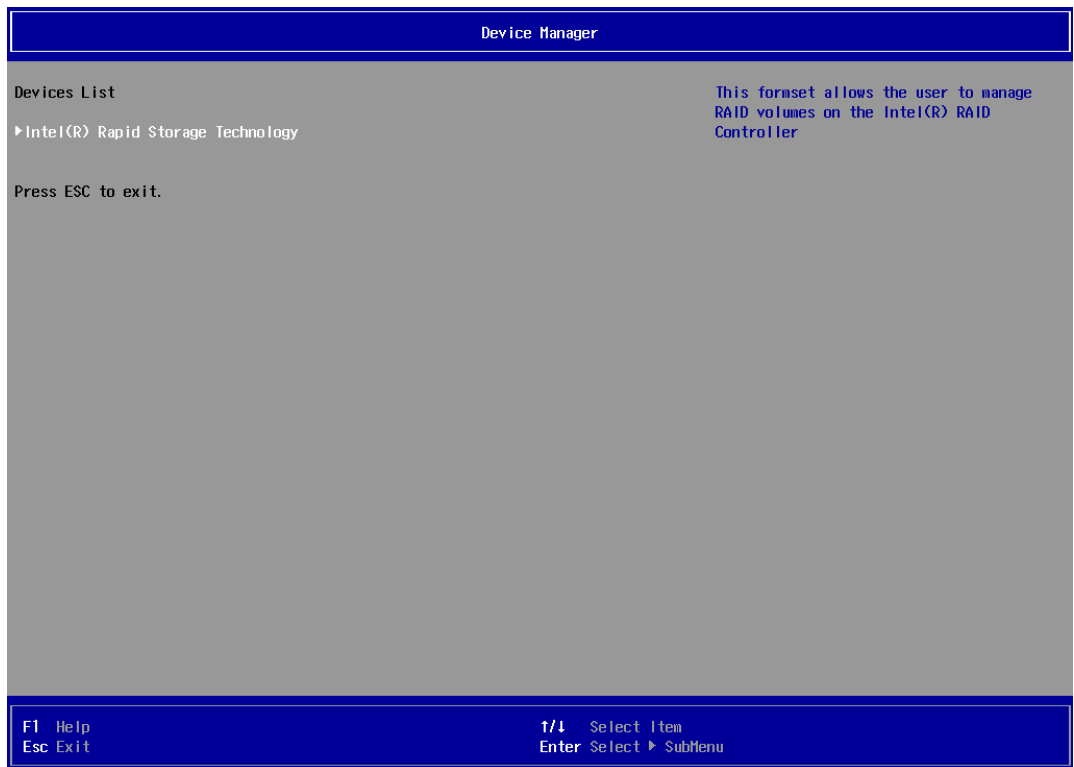

2. The following screen shows Non-RAID physical disks and the option “**Create RAID Volume**”. Highlight “**Create RAID Volume**” and press ENTER to begin creating your RAID volume.

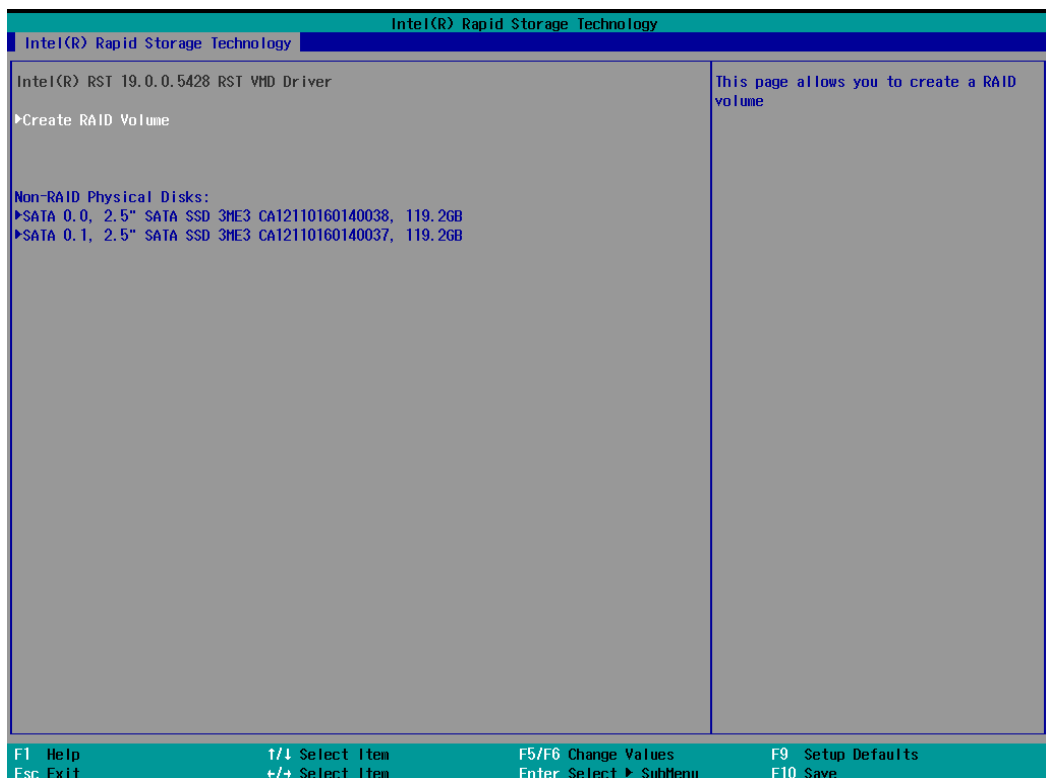

- The Name option allows you to name your RAID volume. Press ENTER when ready to go to the next option.

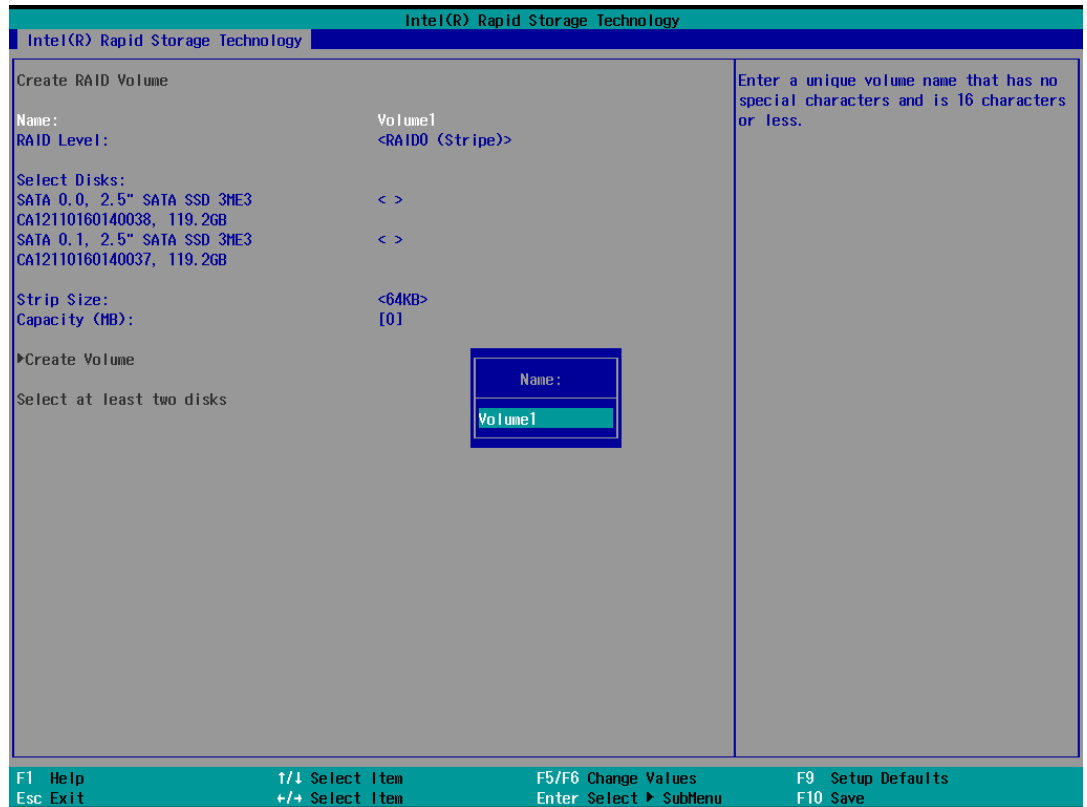

4. The RAID Level option allows you to select RAID-0 (striping) or RAID-1 (mirror) for your RAID volume. Press ENTER when ready.



5. The Select Disks option allows you to select disk drives for your RAID volume. Highlight a drive and press ENTER, use up/ down arrow keys to highlight "x" and press ENTER to confirm the selection. A minimum of two disk drives must be selected for RAID-0 or RAID-1 configuration. Press ENTER when ready.

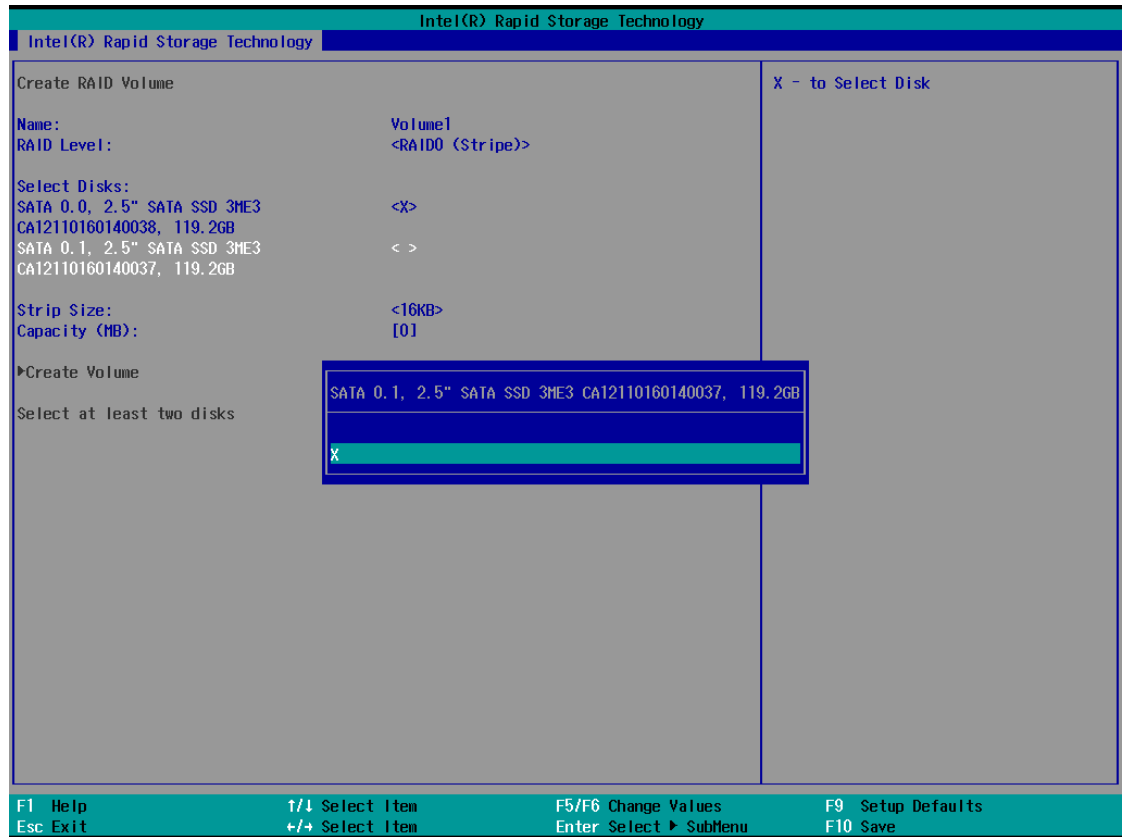

6. The Stripe Size option allows you to configure the stripe size of your RAID volume. Available stripe sizes are 4KB, 8KB, 16KB, 32KB, 64KB, 128KB, use the up and down arrow keys to highlight and press ENTER to confirm the stripe size selection.

*RAID1(Mirror) does not offer Stripe Size options.

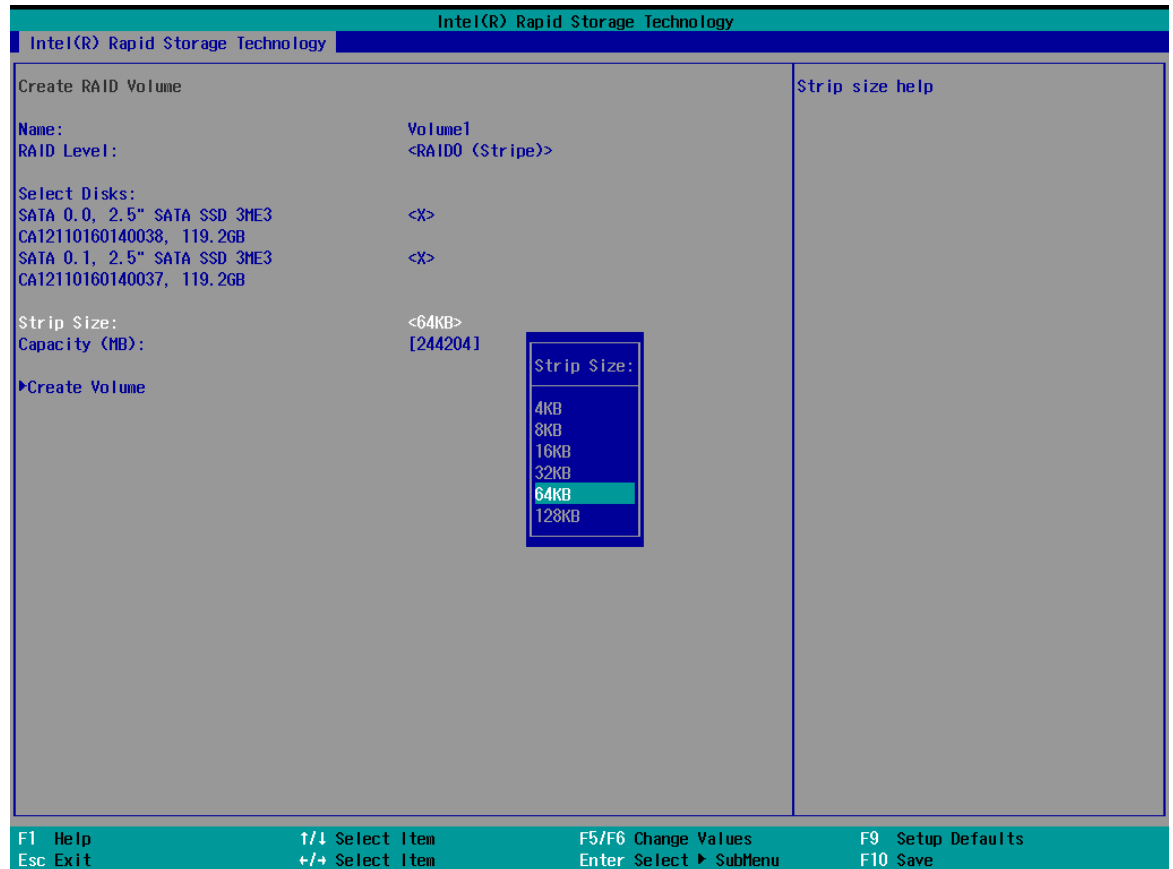

- The Capacity (MB) option allows you to configure the storage capacity of your RAID volume. By default, the full storage capacity will be applied. Once you have entered a capacity, press ENTER to confirm.



- The Create Volume option is the final step in the volume creation process. Highlight “**Create Volume**” and press ENTER to begin creating your RAID volume base on the settings you just configured.

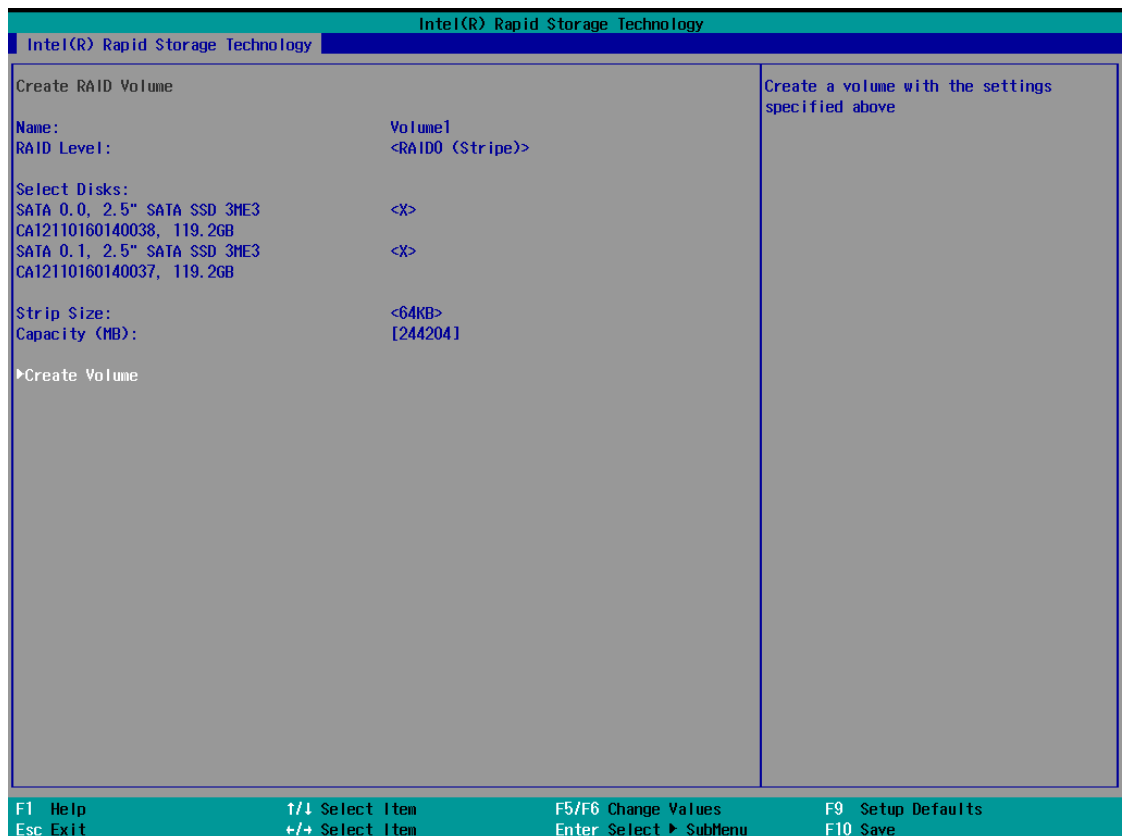

9. A summary and status of the RAID volume will be shown when the RAID volume is successfully created.

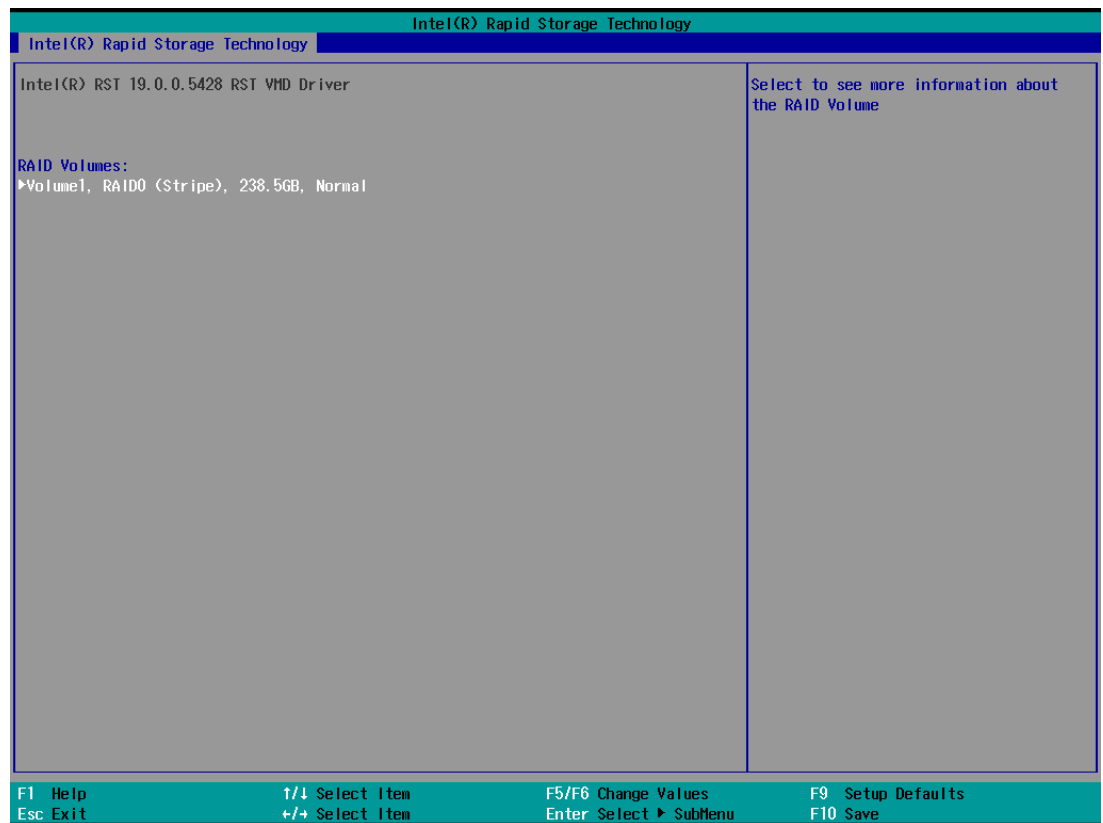

10. Press F10 to save and Esc to exit the Intel® Rapid Storage Technology configuration page.

**NOTE**

The above process was to create a RAID-0 volume. If you wish to create a RAID-1 volume, please perform RAID Volume Setup process and select RAID-1 (Mirror) during step 4.

4.3.3 Loading RAID Driver for Windows Installation

To install Windows on the RAID volume you created, please refer to the following procedure:

1. Please prepare a bootable Windows installation USB drive with [Intel® RST driver](#). Download and unzip the driver files (if need be), copy the driver files onto the Windows installation USB drive.
2. Connect the Windows installation USB drive into one of the USB connections on the system.
3. Windows installation process should automatically begin (if not, please make sure the boot device in BIOS is set properly).
4. Select the “Load Driver” icon.

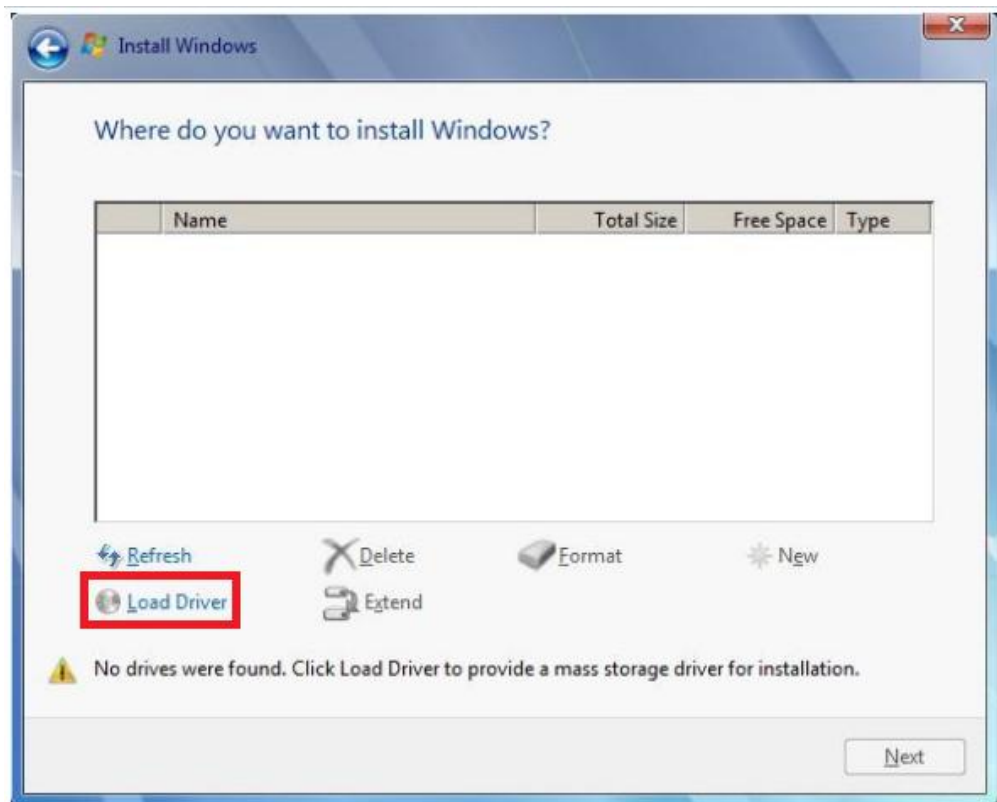

5. In the pop-up Window, select "Browse", go to the directory where you saved the Intel® RST drivers, and click OK.

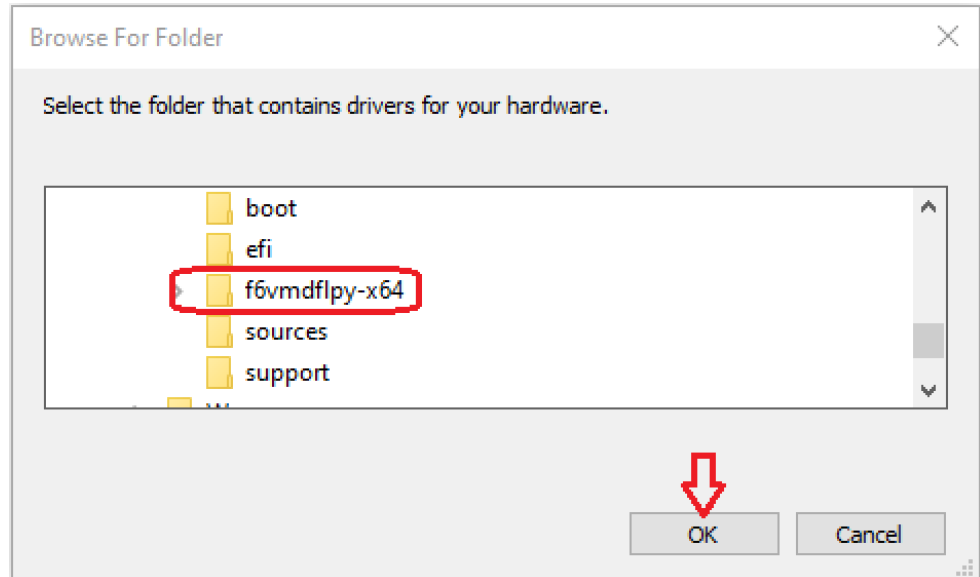
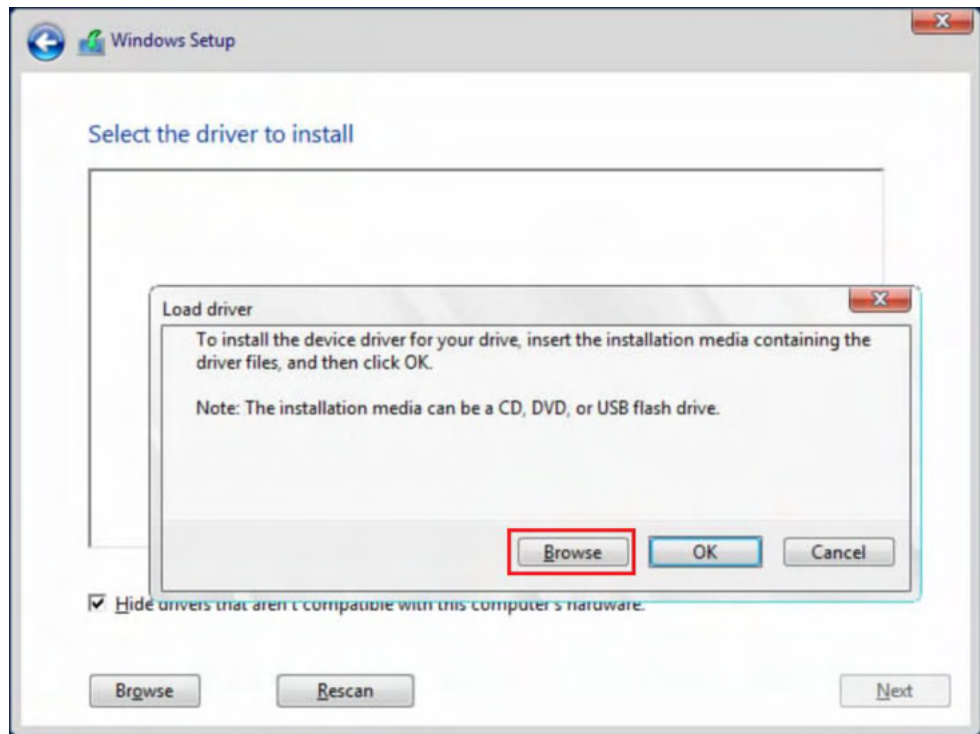

6. Select the driver "Intel RST VMD Controller 467F" and click on Next.

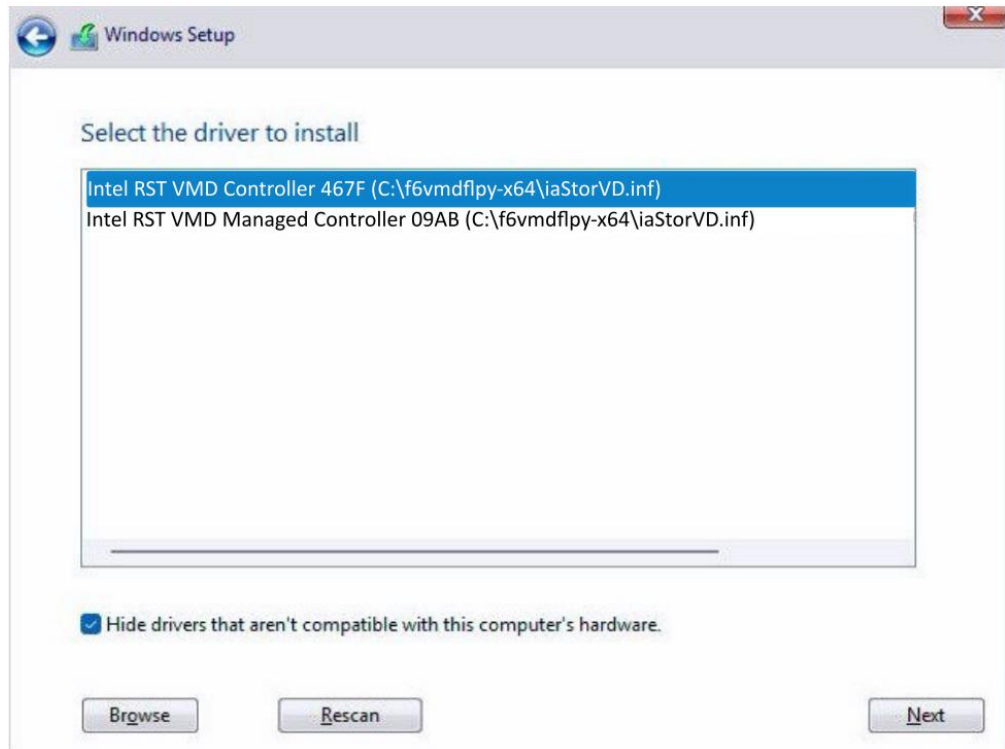

7. The previous created RAID volume shall appear as unallocated space.

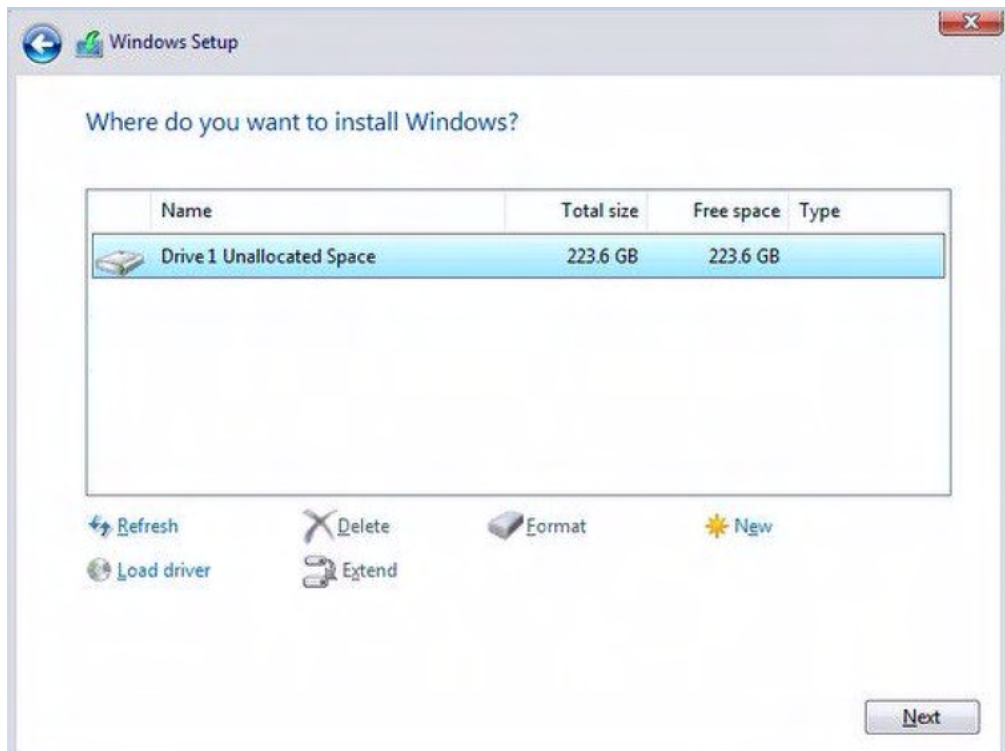

8. From here, just follow the standard Windows installation procedures.

5 OS Support and Driver Installation

5.1 Operating System Compatibility

The system supports most operating system developed for Intel® x86 architecture. The following list contains the operating systems which have been tested by Neosys Technology.

- Microsoft Window 10 LTSC 2021 (x64)
- Ubuntu 20.04.5 LTS, 22.04 LTS, 22.04.1 LTS or other distribution with kernel version ≥ 5.15 */**



NOTE

** For Linux system, user may need to manually compile and install the driver for Intel graphics or I350-AM4 controller if the driver is not embedded in kernel. You can visit Intel website for further information.*

*** For distributions, graphics driver and RAID function may not be completely implemented in its kernel. You may encounter restrictions when using these features, such as triple independent display and RAID. For optimum operation, it is the users' responsibility to manually check for new drivers and upgrades!*

Neosys may remove or update operating system compatibility without prior notice. Please contact us if your operating system of choice is not on the list.

5.2 System Driver Installation

The system drivers are available online, please click on [GT-92 series](#) to download the drivers.

5.3 Driver Installation for Watchdog Timer Control

Neosys provides a driver package which contain function APIs for Watchdog Timer control function. You should install the driver package (WDT_DIO_Setup.exe) in prior to use these functions. Please download the latest version for compatibility.

Please refer to [GT-92 series](#) to download WDT_DIO.

Appendix A Using WDT & DIO

The watchdog timer (WDT) function to ensure reliable system operation. The WDT is a hardware mechanism to reset the system if the watchdog timer is expired. Users can start the WDT and keeping resetting the timer to make sure the system or program is running. Otherwise, the system shall be reset.

In this section, we'll illustrate how to use the function library provided by Neosys to program the WDT functions. Currently, WDT driver library supports Windows 10 x64 and WOW64 platform. For other OS support, please contact Neosys Technology for further information.

Installing WDT_DIO Library

The WDT_DIO function library is delivered in the form of a setup package named **WDT_DIO_Setup.exe**. In prior to program WDT, you should execute the setup program and install the WDT library. Please use the following WDT_DIO_Setup packages according to your operating systems and application.

- For Windows 64-bit OS with 64-bit application (x64 mode), please install the latest WDT_DIO_Setup_.exe file. Please click on the respective series [GT-92 series](#) to download WDT_DIO.

WDT and DIO Library Installation

To setup WDT & DIO Library, please follow instructions below.

1. Execute **WDT_DIO_Setup.exe** and the following dialog appears.

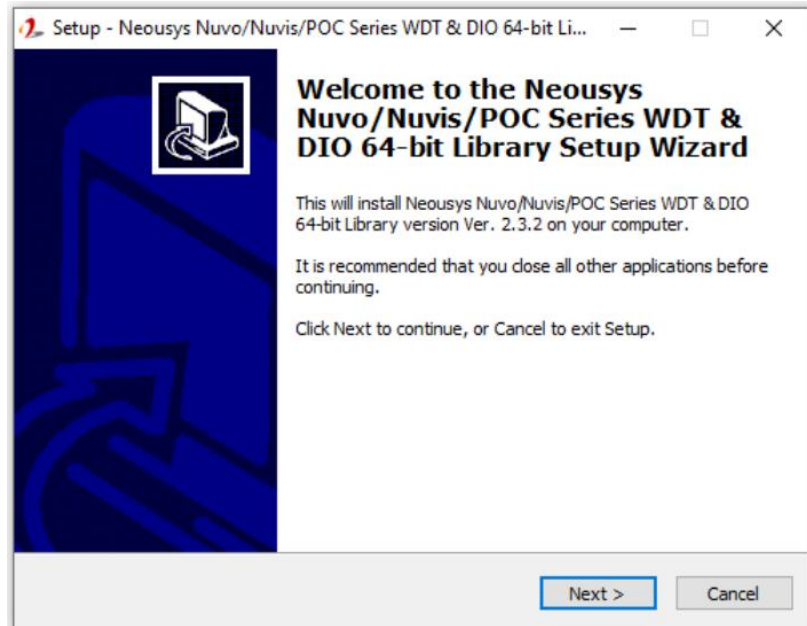

2. Click "Next >" and specify the directory of installing related files. The default directory is `C:\Neosys\WDT_DIO`.

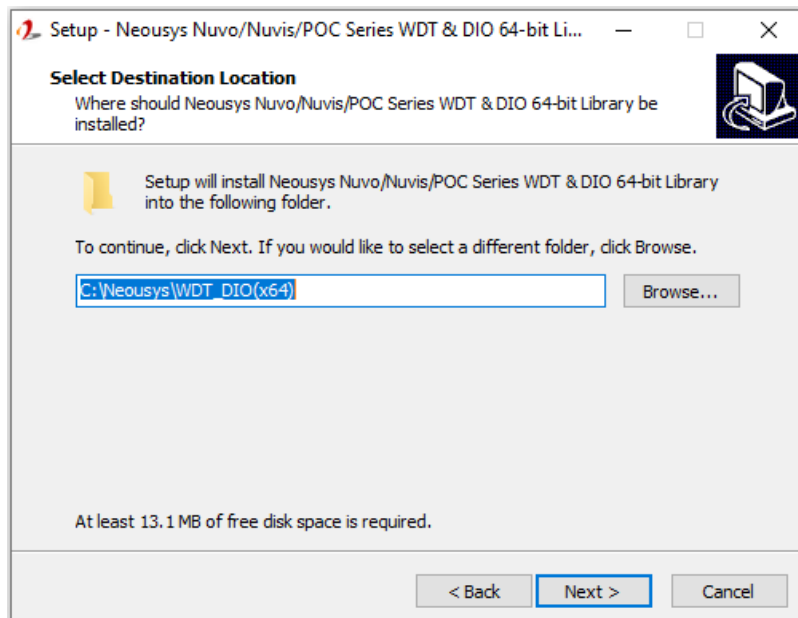

- Once the installation has finished, a dialog will appear to prompt you to reboot the system. The WDT & DIO library will take effect after the system has rebooted.

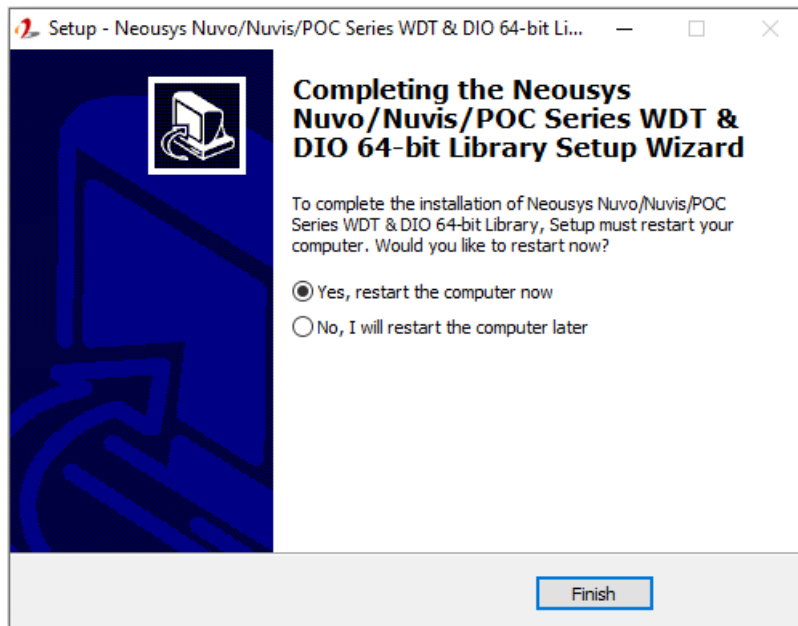

- When programming your WDT or DIO program, the related files are located in

Header File:	\Include
Library File:	\Lib
Function	\Manual
Reference:	
Sample Code:	\Sample\WDT_Demo (Demo for Watchdog Timer)

WDT Functions

InitWDT

Syntax	BOOL InitWDT(void);
Description:	Initialize the WDT function. You should always invoke InitWDT() before set or start watchdog timer.
Parameter	None
Return Value	TRUE: Successfully initialized FALSE: Failed to initialize
Usage	BOOL bRet = InitWDT()

SetWDT

Syntax	BOOL SetWDT(WORD tick, BYTE unit);
Description	Set timeout value and unit for watchdog timer. When InitWDT() is invoked, a default timeout value of 255 seconds is assigned.
Parameter	<i>tick</i> WORD value (1 ~ 65535) to indicate timeout ticks. <i>unit</i> BYTE value (0 or 1) to indicate unit of timeout ticks. 0 : unit is minute 1 : unit is second
Return Value	If value of unit is correct (0 or 1), this function returns TRUE, otherwise FALSE.
Usage	WORD tick=255; BYTE unit=1; //unit is second. BOOL bRet = SetWDT(tick, unit); //timeout value is 255 seconds

StartWDT

Syntax	BOOL StartWDT(void);
Description	Starts WDT countdown. Once started, the WDT LED indicator will begin blinking. If ResetWDT() or StopWDT is not invoked before WDT countdowns to 0, the WDT expires and the system resets.
Parameter	None
Return Value	If the timeout value is given in correct format (WDT started), this function returns TRUE, otherwise FALSE
Usage	BOOL bRet = StartWDT()

ResetWDT

Syntax	BOOL ResetWDT(void);
Description	Reset the timeout value to the value given by SetWDT().If ResetWDT() or StopWDT is not invoked before WDT countdowns to 0, the WDT expires and the system resets.
Parameter	None
Return Value	Always returns TRUE
Usage	BOOL bRet = ResetWDT()

StopWDT

Syntax	BOOL StopWDT(void);
Description	Stops the countdown of WDT. When WDT has stopped, the WDT LED indicator stops blinking.
Parameter	None
Return Value	Always returns TRUE
Usage	BOOL bRet = StopWDT()

Appendix B PoE On/ Off Control

GT-92 series offer 802.3at PoE+ ports and users are allowed to manually turn on or off the power supply of each PoE port. This can be useful in power device (PD) fault-recovery or power reset. The APIs are part of Neosys WDT_DIO driver package. Please follow the instructions in [Appendix A Using WDT & DIO](#) for installation before programming PoE on/off control function.



NOTE

GT-92GC will be shown in illustrations for demonstration purposes.

GetStatusPoEPort

Syntax	BYTE GetStatusPoEPort (Byte port);
Description	Get current on/off status of designated PoE port.
Parameter	<i>port</i> BYTE value specifies the index of PoE port. Please refer to the following illustration, <i>port</i> should be a value of 2 ~ 9
Return Value	BYTE value indicating PoE on/off status 0 if port is disabled (off) 1 if port is enabled (on)
Usage	BYTE bEnabled = GetStatusPoEPort (1); //Get on/off status of PoE Port#1

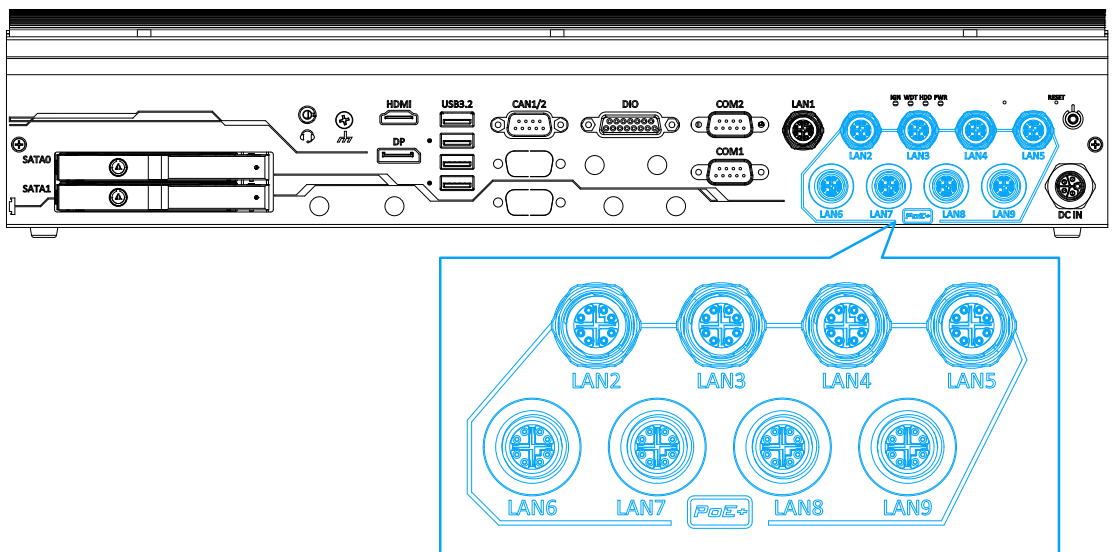

EnablePoEPort

Syntax	BOOL EnablePoEPort (BYTE port);
Description	Turn on PoE power of designated PoE port.
Parameter	<p><i>port</i></p> <p>BYTE value specifies the index of PoE port. Please refer to the following illustration, <i>port</i> should be a value of 2 ~ 9</p>
Return Value	<p>TRUE if enabled success</p> <p>FALSE if fail to enable.</p>
Usage	BOOL bRet = EnablePoEPort (1); //Turn on PoE Port#1

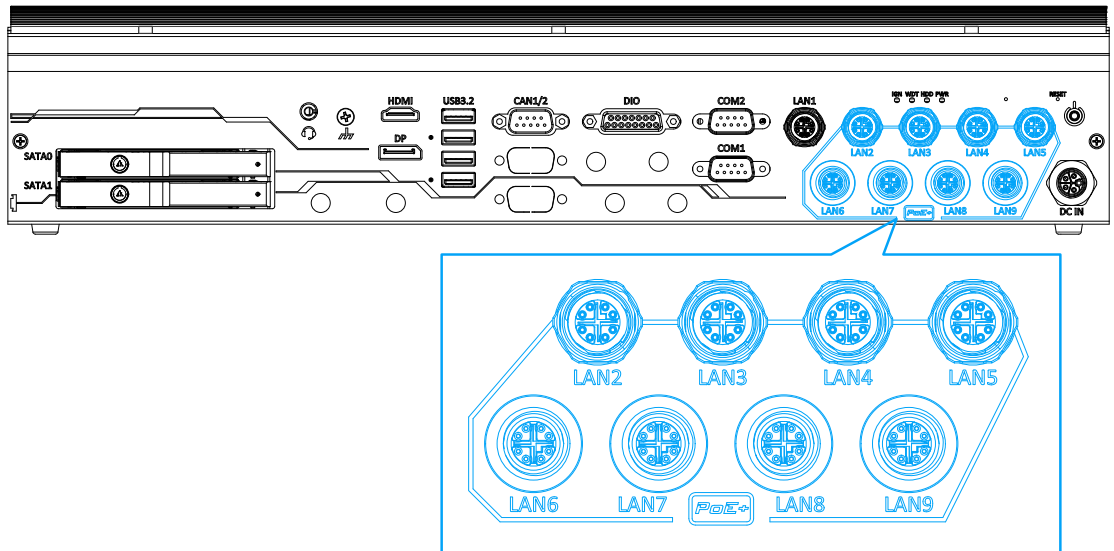

DisablePoEPort

Syntax	BOOL DisablePoEPort (BYTE port);
Description	Turn off PoE power of designated PoE port
Parameter	<i>port</i> BYTE value specifies the index of PoE port. Please refer to the following illustration, <i>port</i> should be a value of 2 ~ 9
Return Value	TRUE if disabled success FALSE if fail to disable
Usage	BOOL bRet = DisablePoEPort (1); //Turn off PoE Port#1

