

**Neousys Technology Inc.**

**NRU-156U3-FT Series**

**User Manual**

Revision 1.0

# Table of Contents

Table of Contents .....	2
Legal Information .....	3
Contact Information .....	4
Notices .....	5
Safety Precautions .....	6
Service and Maintenance .....	7
ESD Precautions .....	7
About This Manual .....	8

## 1 Introduction

1.1 NRU-156U3-FT Specification .....	10
1.2 NRU-154PoE-FT Specification .....	11
1.3 Dimensions of NRU-15x-FT Series .....	12
1.4 Flattop Heatsink Mounting Measurements .....	13

## 2 Setting Up Your NX154PoE

2.1 Unpacking Your NRU-15x-FT system .....	14
2.2 NRU-156U3-FT Camera Connectivity .....	15
2.2.1 USB 3.2 Gen 2 Ports .....	16
2.2.2 USB 3.2 Gen 1 Ports .....	16
2.2.3 8-pin Terminal Block .....	17
2.3 NRU-154PoE-FT .....	18
2.3.1 Gigabit Power over Ethernet Ports .....	19
2.3.2 8-pin Terminal Block .....	20
2.4 Onboard System Connectivity .....	21
2.4.1 Ethernet Port .....	22
2.4.2 DisplayPort .....	23
2.4.3 USB2.0 Port .....	23
2.4.4 6-pin 12V DC Input .....	24
2.5 Onboard NVIDIA Jetson Orin NX Module .....	25
2.6 Onboard M.2 2242 M Key Slot for NVMe SSD .....	26
2.7 DIP Switch .....	27

## 3 System Installation

3.1 System Disassembly .....	29
3.2 NVIDIA Jetson SoM .....	32
3.3 M.2 2242 M Key NVMe SSD Installation .....	34
3.4 Reinstalling the Enclosure .....	35
3.5 Installing NRU-15x-FT into Enclosure .....	38

## 4 Reflashing the NRU-15x-FT

# Legal Information

All Neosys Technology Inc. products shall be subject to the latest Standard Warranty Policy.

Neosys Technology Inc. may modify, update or upgrade the software, firmware or any accompanying user documentation without prior notice. Neosys Technology Inc. will provide access to these new software, firmware or documentation releases from download sections of our website or through our service partners.

Before installing any software, applications or components provided by a third party, customer should ensure that they are compatible and interoperable with Neosys Technology Inc. product by checking in advance with Neosys Technology Inc.. Customer is solely responsible for ensuring the compatibility and interoperability of the third party's products. Customer is further solely responsible for ensuring its systems, software, and data are adequately backed up as a precaution against possible failures, alteration, or loss.

For questions in regards to hardware/ software compatibility, customers should contact Neosys Technology Inc. sales representative or technical support.

To the extent permitted by applicable laws, Neosys Technology Inc. shall NOT be responsible for any interoperability or compatibility issues that may arise when (1) products, software, or options not certified and supported; (2) configurations not certified and supported are used; (3) parts intended for one system is installed in another system of different make or model.

# Contact Information

---

**Headquarters**  
**(Taipei, Taiwan)**

**Neosys Technology Inc.**

15F, No.868-3, Zhongzheng Rd., Zhonghe Dist., New Taipei City, 23586, Taiwan

Tel: +886-2-2223-6182 Fax: +886-2-2223-6183 [Email](#), [Website](#)

---

**Americas**  
**(Illinois, USA)**

**Neosys Technology America Inc.**

3384 Commercial Avenue, Northbrook, IL 60062, USA

Tel: +1-847-656-3298 [Email](#), [Website](#)

---

**China**

**Neosys Technology (China) Ltd.**

Room 612, Building 32, Guiping Road 680, Shanghai

Tel: +86-2161155366 [Email](#), [Website](#)

# Notices

<b>Copyright</b>	All rights reserved. This publication may not be reproduced, transmitted, transcribed, stored in a retrieval system, or translated into any language or computer language, in any form or by any means, electronic, mechanical, magnetic, optical, chemical, manual or otherwise, without the prior written consent of Neosys Technology, Inc.
<b>Disclaimer</b>	This manual is intended to be used as an informative guide only and is subject to change without prior notice. It does not represent commitment from Neosys Technology Inc. Neosys Technology Inc. shall not be liable for any direct, indirect, special, incidental, or consequential damages arising from the use of the product or documentation, nor for any infringement on third party rights.
<b>Patents and Trademarks</b>	Neosys, the Neosys logo, Expansion Cassette, MezIO™ are registered patents and trademarks of Neosys Technology, Inc. Windows is a registered trademark of Microsoft Corporation. Intel®, Core™ are registered trademarks of Intel Corporation NVIDIA®, GeForce® are registered trademarks of NVIDIA Corporation All other names, brands, products or services are trademarks or registered trademarks of their respective owners.
<b>FCC Conformity</b>	This equipment has been tested and found to comply with the limits for a Class A digital device, pursuant to part 15 of the FCC Rules. These limits are designed to provide reasonable protection against harmful interference when the equipment is operated in a commercial environment. This equipment generates, uses, and can radiate radio frequency energy and, if not installed and used in accordance with the instruction manual, may cause harmful interference to radio communications. Operation of this equipment in a residential area is likely to cause harmful interference in which case the user will be required to correct the interference at his own expense.
<b>CE Conformity</b>	The product(s) described in this manual complies with all applicable European Union (CE) directives if it has a CE marking. For computer systems to remain CE compliant, only CE-compliant parts may be used. Maintaining CE compliance also requires proper cable and cabling techniques.

# Safety Precautions

Read these instructions carefully before you install, operate, or transport the system.

- Install the system or DIN rail associated with, at a sturdy location
- Install the power socket outlet near the system where it is easily accessible
- Secure each system module(s) using its retaining screws
- Place power cords and other connection cables away from foot traffic.
- Do not place items over power cords and make sure they do not rest against data cables
- Shutdown, disconnect all cables from the system and ground yourself before touching internal modules
- Ensure that the correct power range is being used before powering the device
- Should a module fail, arrange for a replacement as soon as possible to minimize down-time
- If the system is not going to be used for a long time, disconnect it from mains (power socket) to avoid transient over-voltage

# Service and Maintenance

- ONLY qualified personnel should service the system
- Shutdown the system, disconnect the power cord and all other connections before servicing the system
- When replacing/ installing additional components (expansion card, memory module, etc.), insert them as gently as possible while assuring proper connector engagement

## ESD Precautions

- Handle add-on module, motherboard by their retention screws or the module's frame/ heat sink.
- Avoid touching the PCB circuit board or add-on module connector pins
- Use a grounded wrist strap and an anti-static work pad to discharge static electricity when installing or maintaining the system
- Avoid dust, debris, carpets, plastic, vinyl and styrofoam in your work area.
- Do not remove any module or component from its anti-static bag before installation

# About This Manual

This manual introduces and describes how to setup/ install Neosys Technology NRU-15x-FT series, available in an ultra-compact enclosure formfactor. It is a turnkey industrial-grade frame grabber solution with AI computation capabilities that incorporates drivers for selected Ethernet/ GigE cameras with video streaming sample codes.

## Revision History

Version	Date	Description
1.0	Jul. 2024	Initial release



# 1 Introduction

The NRU-150-FT series is a compact, fanless edge AI computer incorporating Jetson Orin NX and independent 2.5GbE PoE+ or USB 3 camera connectivity. Its special flattop heatsink is designed to be mounted inside a sealed enclosure to aid metal processing, food processing, smart agriculture, or roadside applications, where it can be protected from environments that contain dust, metal particles or fluid.



**NRU-156U3-FT**



**NRU-154PoE-FT**

Benefiting from the power efficient NVIDIA® Jetson Orin™ NX, the NRU-150-FT series can deliver up to 100 TOPS inference performance in a 25W power package. Offering full bandwidth each port to complement versatile video inputs for edge inspection, NRU-154PoE-FT features 4x 2.5GbE PoE+ ports for IP cameras and industrial GigE cameras, and NRU-156U3-FT features 6x USB 3.2 ports for industrial USB3 cameras.

The flattop heatsink design further expands application scenarios by allowing users to mount the NRU-150-FT series inside a sealed enclosure and conduct the heat to the outer surface, offering a -25 to 60°C wide-temperature fanless operation. It makes NRU-150-FT suitable for environments such as dusty roadsides, humidity farms, and harbors. Moreover, it is also applicable to versatile AI-based factory automation for metal, wood, food, and chemical processing.

By integrating full-bandwidth 2.5GbE PoE+/ USB3 ports for camera connectivity, 100 TOPS AI inference performance, unique flattop heatsink for enclosed installation, and a vast array of NVIDIA AI JetPack toolkits, the NRU-150-FT series presents more possibilities for edge inspection in harsh environments, where dustproof, waterproof, or flameproof protection is needed.

## 1.1 NRU-156U3-FT Specification

System Core	
<b>Processor</b>	Supporting NVIDIA® Jetson Orin™ NX system-on-module (SOM), comprising NVIDIA® Ampere GPU and ARM Cortex CPU
<b>Memory</b>	8GB/ 16GB LPDDR5 @ 3200 MHz on SOM
Storage Interface	
<b>M.2 NVMe</b>	1x M.2 2242 M key socket (PCIe Gen4 x2) for NVMe SSD
Deployment I/O Interface	
<b>Bus Interface</b>	X1, Gen2 PCI Express
<b>USB3</b>	2x USB 3.2 Gen2 (10Gbps) ports 4x USB 3.2 Gen1 (5Gbps) ports
<b>Serial Port</b>	1x RS-232 port and 1x isolated RS-485 port
Development I/O Interface	
<b>Ethernet port</b>	1x Gigabit Ethernet
<b>USB</b>	2x USB 2.0 ports 1x micro USB (OTG)
<b>Video Port</b>	1x DisplayPort, supporting 3840x2160 at 60Hz
<b>DC Input</b>	12V DC power input (for standalone development, or when total power consumption exceeds 66W)
Mechanical	
<b>Dimension</b>	116mm (W) x 171mm (D) x 27mm (H) (without wall-mount bracket)
<b>Weight</b>	1.0 kg
Environmental	
<b>Operating Temperature</b>	-25°C to 60°C with airflow (20W TDP mode) * fanless operating temperature while mounted on 50 x 50 x 0.2cm metallic plate of cabinet/ enclosure
<b>Storage Temperature</b>	-40°C to 85°C
<b>Humidity</b>	10% to 90%, non-condensing
<b>Shock</b>	Shock operating, MIL-STD-810H, Method 516.8, Procedure I
<b>EMC</b>	EMC CE/FCC Class A, according to EN 55032 & EN 55035

\* For sub-zero and over 60°C operating temperature, a wide temperature NVMe is required.

## 1.2 NRU-154PoE-FT Specification

System Core	
<b>Processor</b>	Supporting NVIDIA® Jetson Orin™ NX system-on-module (SOM), comprising NVIDIA® Ampere GPU and ARM Cortex CPU
<b>Memory</b>	8GB/ 16GB LPDDR5 @ 3200 MHz on SOM
Storage Interface	
<b>M.2 NVMe</b>	1x M.2 2242 M key socket (PCIe Gen4 x2) for NVMe SSD
Deployment I/O Interface	
<b>Bus Interface</b>	X1, Gen2 PCI Express
<b>PoE</b>	4x IEEE 802.3at PoE+ Max 25.5W per port. Total 50W power budget for 4 ports
<b>Ethernet</b>	4x 2.5GBASE-T Ethernet ports
<b>Serial Port</b>	1x RS-232 port and 1x isolated RS-485 port
Development I/O Interface	
<b>Ethernet port</b>	1x Gigabit Ethernet
<b>USB</b>	2x USB 2.0 ports 1x micro USB (OTG)
<b>Video Port</b>	1x DisplayPort, supporting 3840x2160 at 60Hz
<b>DC Input</b>	12V DC power input (for standalone development, or when total power consumption exceeds 66W)
Mechanical	
<b>Dimension</b>	116mm (W) x 171mm (D) x 27mm (H) (without wall-mount bracket)
<b>Weight</b>	1.0 kg
Environmental	
<b>Operating Temperature</b>	-25°C to 60°C with airflow (20W TDP mode) * fanless operating temperature while mounted on 50 x 50 x 0.2cm metallic plate of cabinet/ enclosure
<b>Storage Temperature</b>	-40°C to 85°C
<b>Humidity</b>	10% to 90%, non-condensing
<b>Shock</b>	Shock operating, MIL-STD-810H, Method 516.8, Procedure I
<b>EMC</b>	EMC CE/FCC Class A, according to EN 55032 & EN 55035

\* For sub-zero and over 60°C operating temperature, a wide temperature NVMe is required.

### 1.3 Dimensions of NRU-15x-FT Series



*Both NRU-156U3-FT and NRU-154PoE-FT share the same dimensions. Therefore, only NRU-156U3-FT will be shown for demonstration purposes.*

*All measurements are in millimeters (mm).*

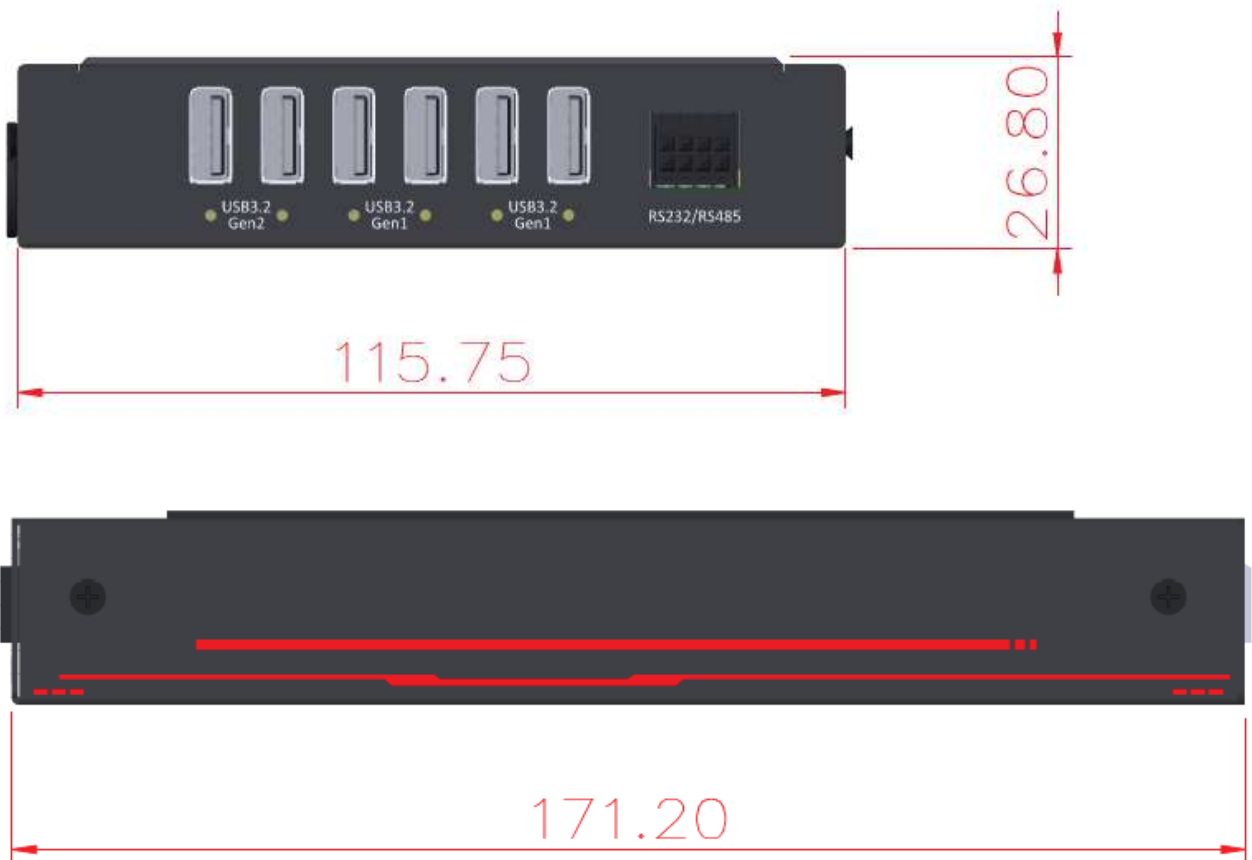

## 1.4 Flattop Heatsink Mounting Measurements



### NOTE

*All measurements are in millimeters (mm).*

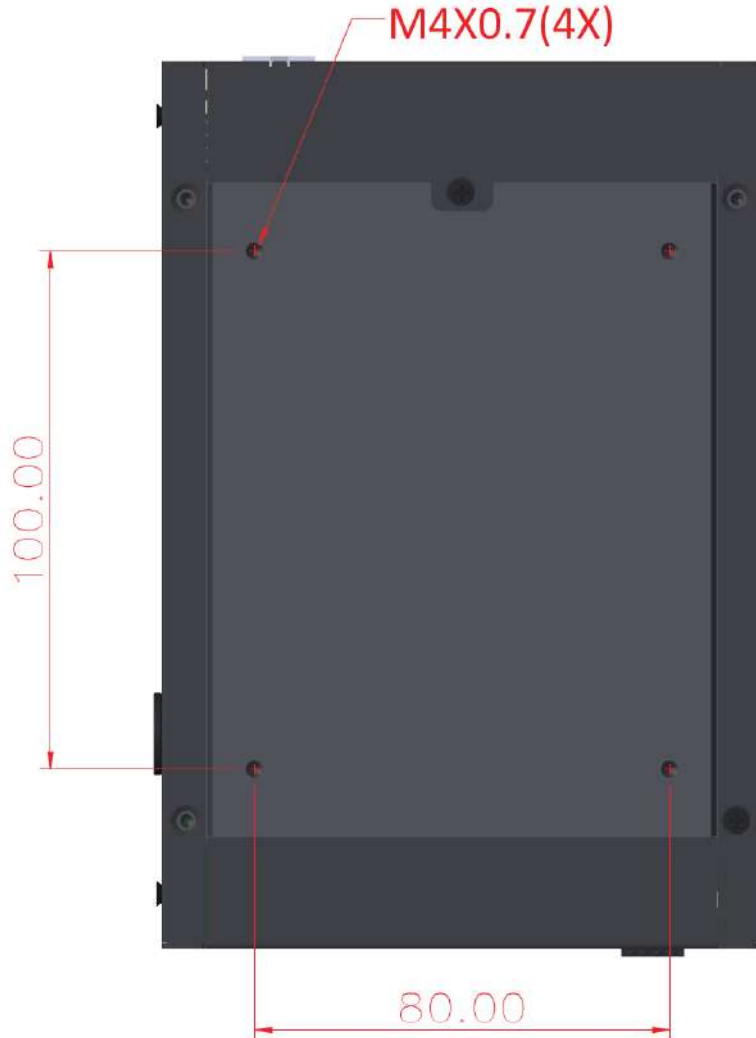

## 2 Setting Up Your NX154PoE

### 2.1 Unpacking Your NRU-15x-FT system

Upon receiving the NRU-15x-FT system, please check immediately if the package contains all the items listed in the following table. If any item is missing or damaged, please contact your local dealer or Neousys Technology.

Item	Description	Qty
1	NRU-15x-FT frame grabber	1
2	6P(2x3) 4.2mm wafer to 2x cord end terminal 20cm cable	1
3	Inline splicing connector for development	2
4	Push-in 8-pole(2x4) terminal block for RS232 and isolated RS485	1
5	NRU-15x-FT wall mount bracket	2
6	Screw pack	1

## 2.2 NRU-156U3-FT Camera Connectivity

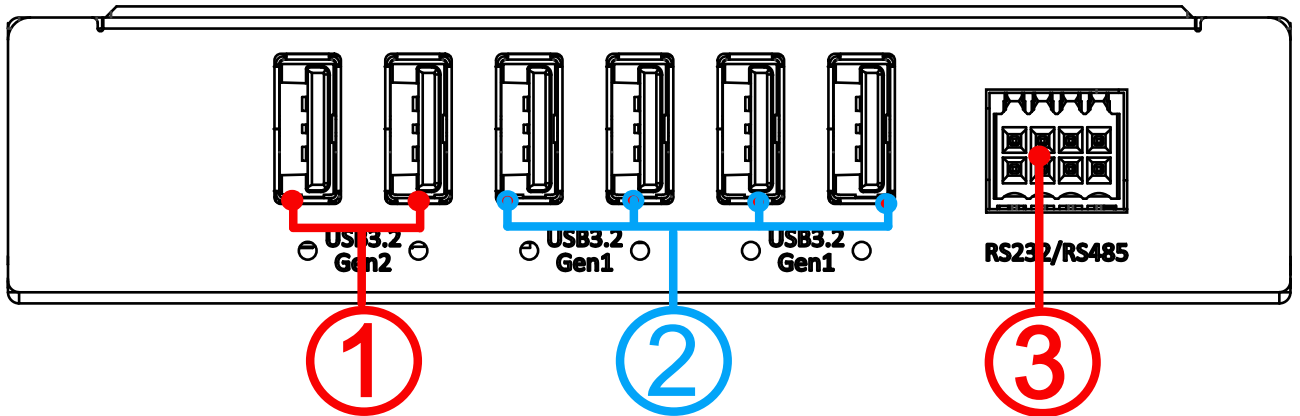

No.	Item	Description
1.	USB 3.2 Gen 2 ports	USB 3.2 Gen 2 port (SuperSpeed+) offers up to 10Gbps, twice the bandwidth over existing SuperSpeed USB3.1 Gen. 1 connection. They are backward compatible with USB3.2 Gen1 and USB2.0.
2.	USB 3.2 Gen 1 ports	USB 3.2 Gen 1 offers up to 5Gbps of data-throughput performance. They are backward compatible with USB2.0.
3.	8-pin terminal block	The 8-pin terminal includes signals for a RS-232 and an isolated RS-485 COM.

### 2.2.1 USB 3.2 Gen 2 Ports

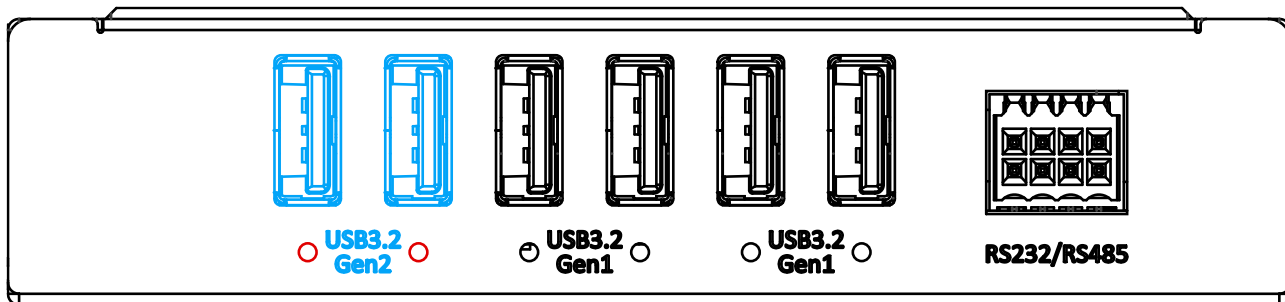

The system’s USB 3.2 Gen 2 ports (10Gbps) are backward compatible with USB3.2 Gen.1 USB 2.0, USB 1.1 and USB 1.0 devices.

Indicated in **red** are screw-lock mechanisms to ensure connectivity in constant shock and vibration conditions.

Legacy USB support is also provided so you can use USB keyboard/mouse in DOS environment.

### 2.2.2 USB 3.2 Gen 1 Ports

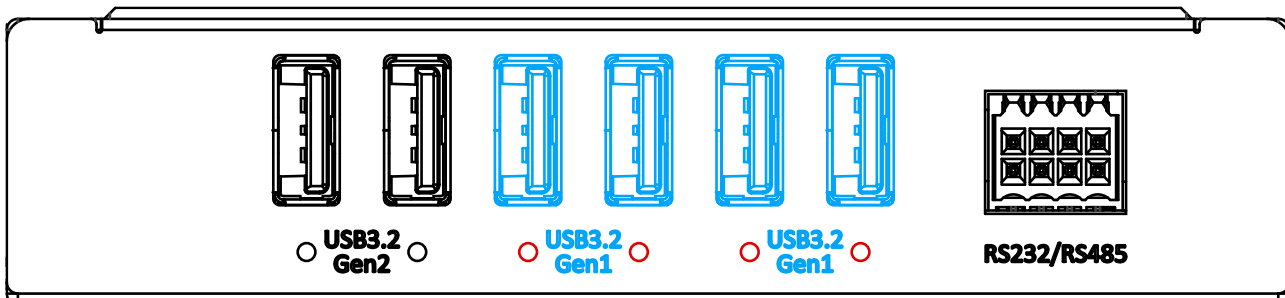

The system’s USB 3.2 Gen1x1 ports (5Gbps) are backward compatible with USB 2.0, USB 1.1 and USB 1.0 devices.

Indicated in **red** are screw-lock mechanisms to ensure connectivity in constant shock and vibration conditions.

Legacy USB support is also provided so you can use USB keyboard/mouse in DOS environment.



### 2.2.3 8-pin Terminal Block

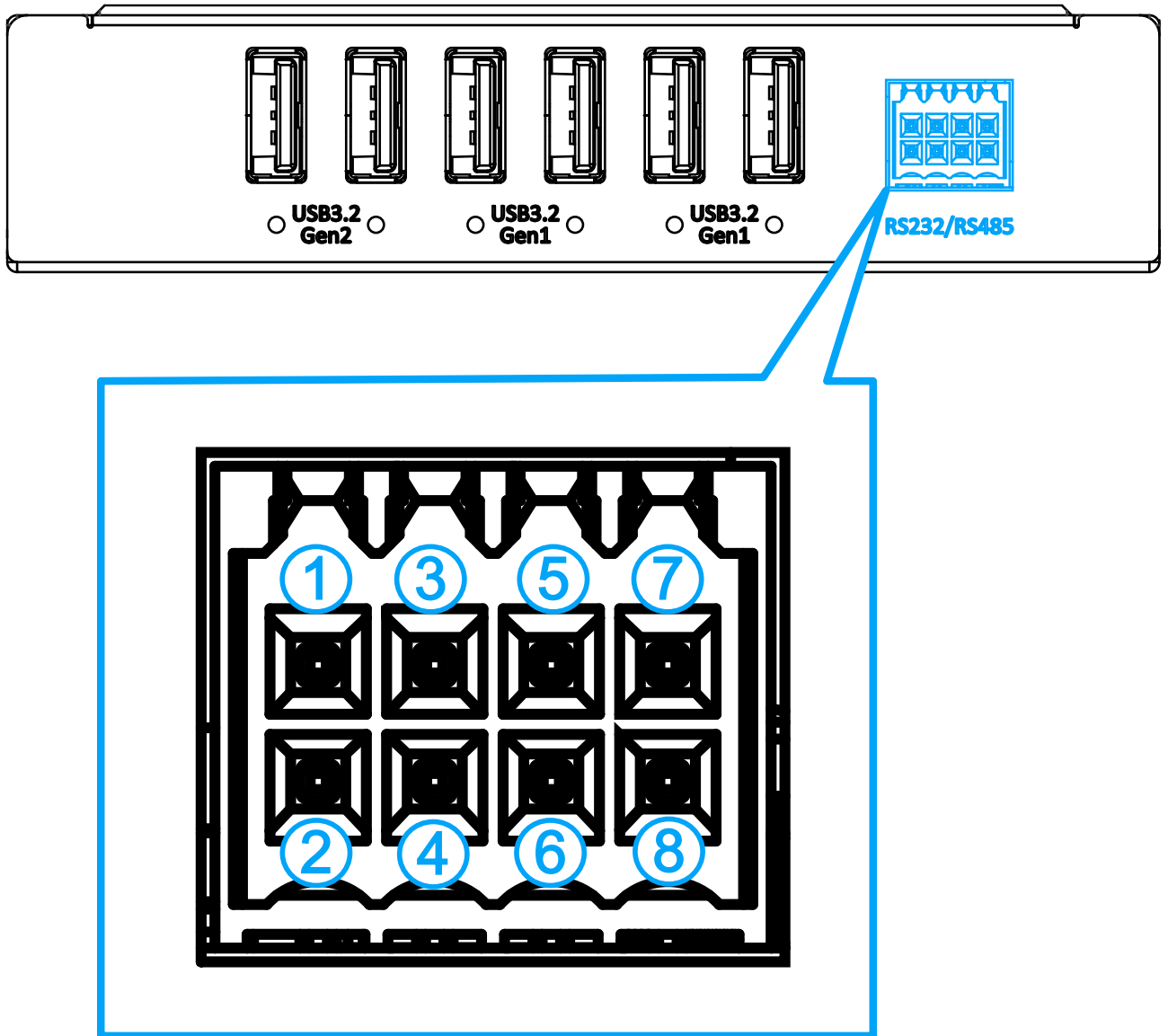

The terminal includes signals for a RS-232 and an isolated RS-485 COM. For pin definitions, please refer to the following table:

Pin	Description	Pin	Description
1	-	5	RS-485_GND
2	-	6	RS-232_GND
3	RS485_DATA+	7	RS-232_TX
4	RS-485_DATA-	8	RS-232_RX

## 2.3 NRU-154PoE-FT

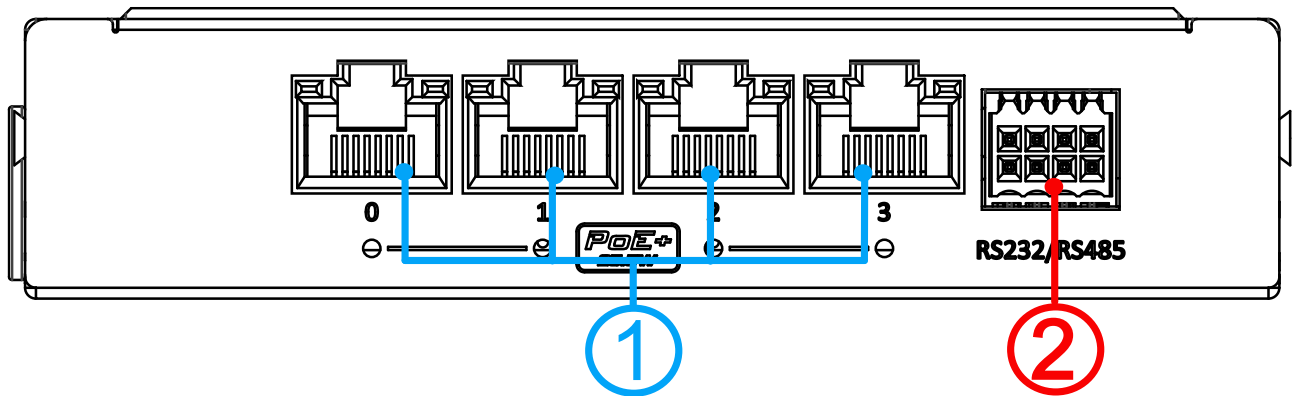





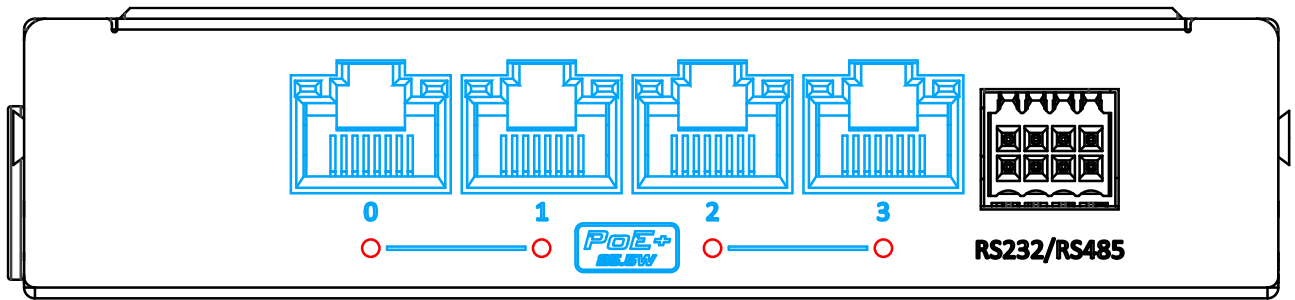





No.	Item	Description
1.	Gigabit Power Over Ethernet ports	4x 2.5GBASE-T Ethernet ports in compliance with IEEE 802.3at PoE+, maximum 25.5W per port, and a total 50W power budget for 4 ports
2.	8-pin terminal block	The 8-pin terminal includes signals for a RS-232 and an isolated RS-485 COM.

### 2.3.1 Gigabit Power over Ethernet Ports



The NRU-154PoE series offers four Gigabit Ethernet ports with Power over Ethernet (PoE) functionality. Indicated in **red** are screw-lock mechanisms to ensure connectivity in constant shock and vibration conditions.

Power over Ethernet (PoE) supplies electrical power and data on a standard CAT-5/ CAT-6 Ethernet cable. Acting as a PoE PSE (Power Sourcing Equipment), compliant with IEEE 802.3at, each PoE port delivers up to 25W to a Powered Device (PD). The four ports have a total 50W power budget. PoE ports can automatically detect and determine if the connected device requires power or not, so it is compatible with standard Ethernet devices as well. Please refer to the following LED indicators for port statuses.

LAN Speed	LED Status	LED Color/ Behavior
10Mbps	Link/ Active	 Orange (blinking)
	Speed	 Off
100Mbps	Link/ Active	 Orange (blinking)
	Speed	 Off
1.0Gbps	Link/ Active	 Orange (blinking)
	Speed	 Green
2.5Gbps	Link/ Active	 Orange (blinking)
	Speed	 Orange
No link	Link/ Active	 Off
	Speed	 Off

### 2.3.2 8-pin Terminal Block

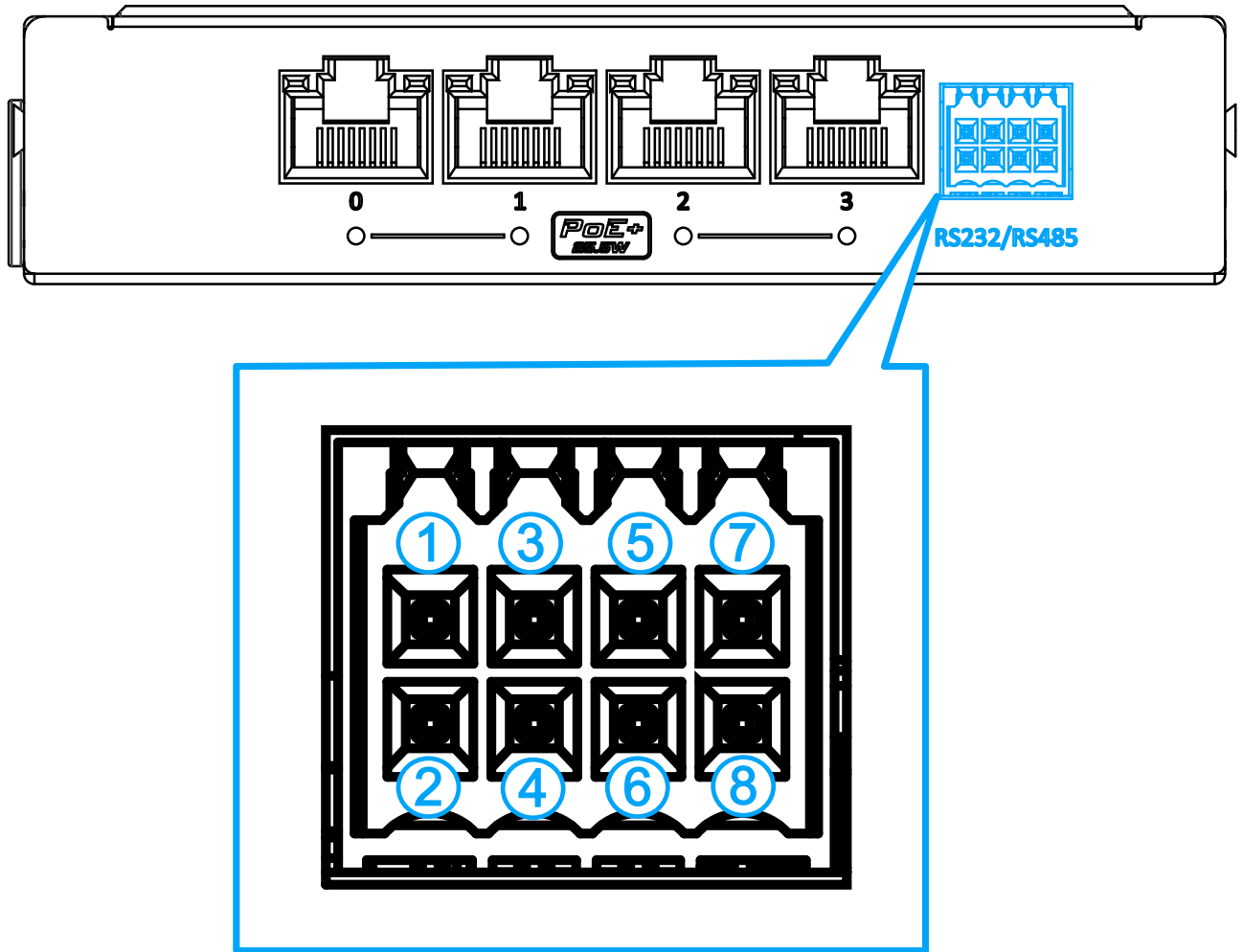

The terminal includes signals for a RS-232 and an isolated RS-485 COM. For pin definitions, please refer to the following table:

Pin	Description	Pin	Description
1	-	5	RS-485_GND
2	-	6	RS-232_GND
3	RS485_DATA+	7	RS-232_TX
4	RS-485_DATA-	8	RS-232_RX

## 2.4 Onboard System Connectivity



**NOTE**

*NRU-15x-FT systems share the same onboard system connectivity.*

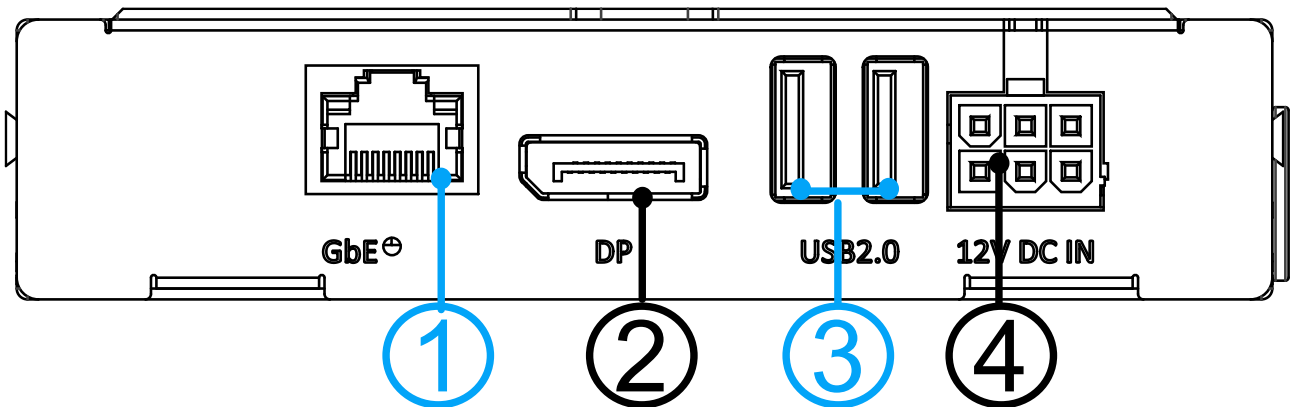

No.	Item	Description
1.	Gigabit Ethernet	The Ethernet ports support 10/ 100/ 1000Mbps network connections.
2.	DisplayPort	Support display resolutions up to 3840 x 2160. Compatible with HDMI/ DVI via an <b>active</b> adapter/ cable (support resolution may vary).
3	USB2.0 ports	The USB 2.0 ports are compatible with USB 1.1 / 1.0.
4	6-pin 12V DC input	The 6-pin supports 12V DC input as power source.

### 2.4.1 Ethernet Port

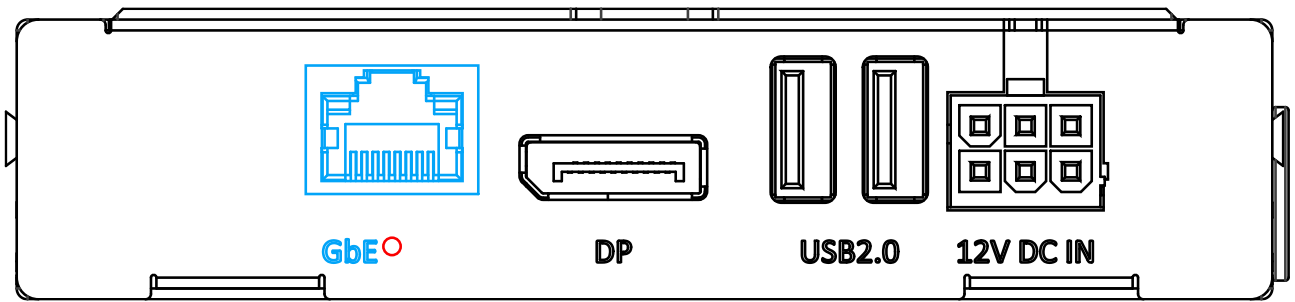

There is an Ethernet port that is compatible with 1000/ 100/ 10 Mbit link speeds. Relevant drivers may need to be installed before you can utilize the port. Indicated in **red** are screw-lock mechanisms to ensure connectivity in constant shock and vibration conditions.

Please refer to the table below for LED connection statuses.

LAN Speed	LED	LAN
10 Mbps	Link/Active	Orange (blink)
	Speed	Off
100 Mbps	Link/Active	Orange (blink)
	Speed	Off
1.0 Gbps	Link/Active	Orange (blink)
	Speed	Orange
No Link	Link/Active	Off
	Speed	Off

## 2.4.2 DisplayPort

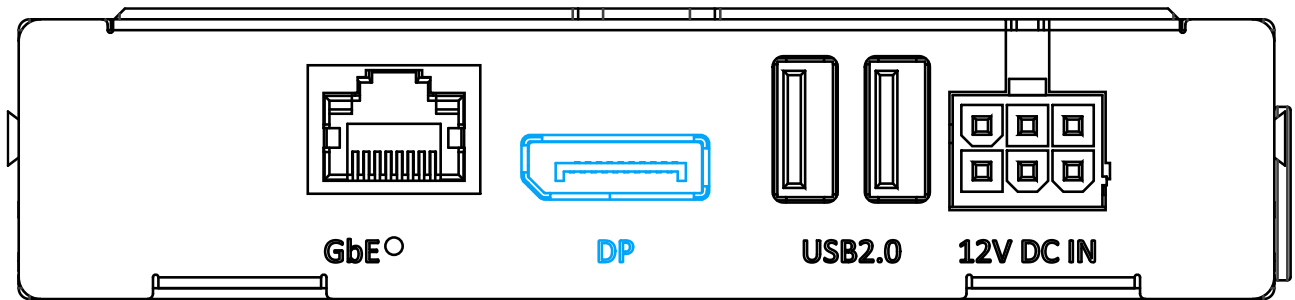

The system has a DisplayPort (DP) output which is a digital display interface that mainly connect video source and carry audio to a display device. It can deliver up to 3840 x 2160 in resolution and is designed to support **active** DP adapter/ cable. You can connect to display devices using DP-to-HDMI cable or DP-to-DVI cable.

Relevant drivers may need to be installed before you can utilize the port.



**DP-to-HDMI**



**DP-to-DVI**

## 2.4.3 USB2.0 Port

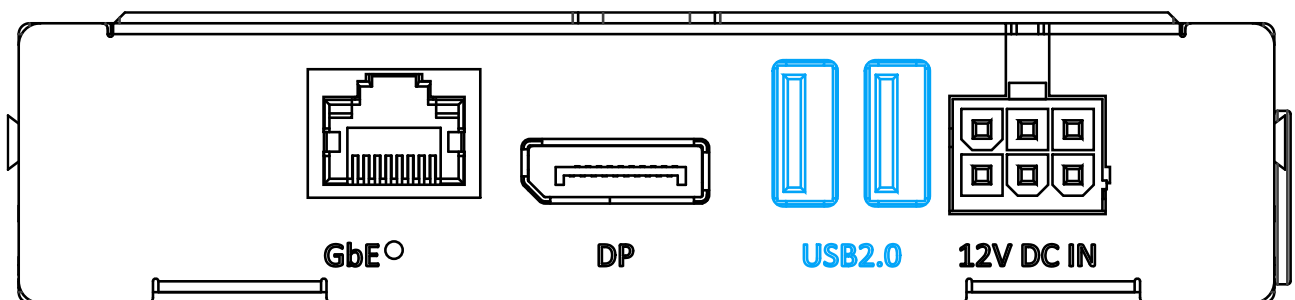

The USB2.0 ports are backward compatible with USB 1.1 and USB 1.0 devices.

Relevant drivers may need to be installed before you can utilize the port.

### 2.4.4 6-pin 12V DC Input

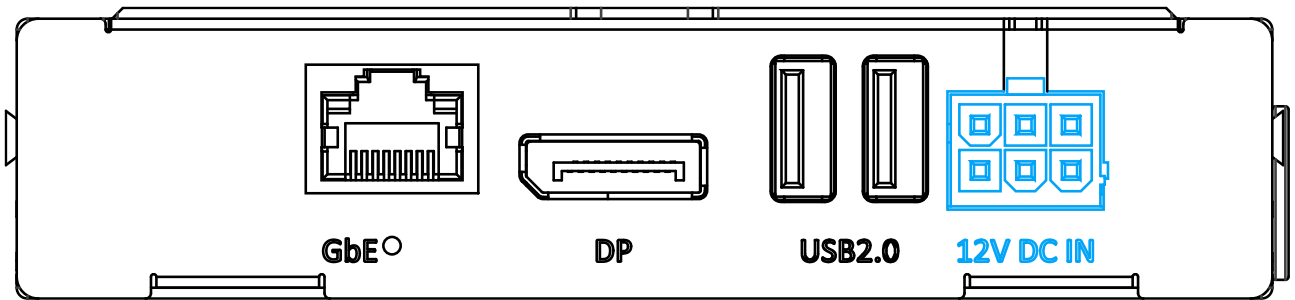

The 4-pin plug can support 12V DC input as the power source.

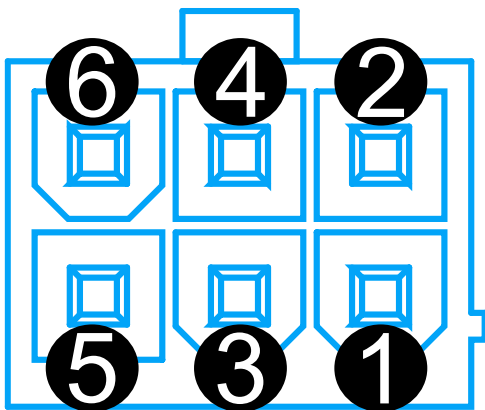

#### Pin Definition

Pin	Description
1	12V
2	GND
3	12V
4	GND
5	12V
6	GND



## 2.5 Onboard NVIDIA Jetson Orin NX Module

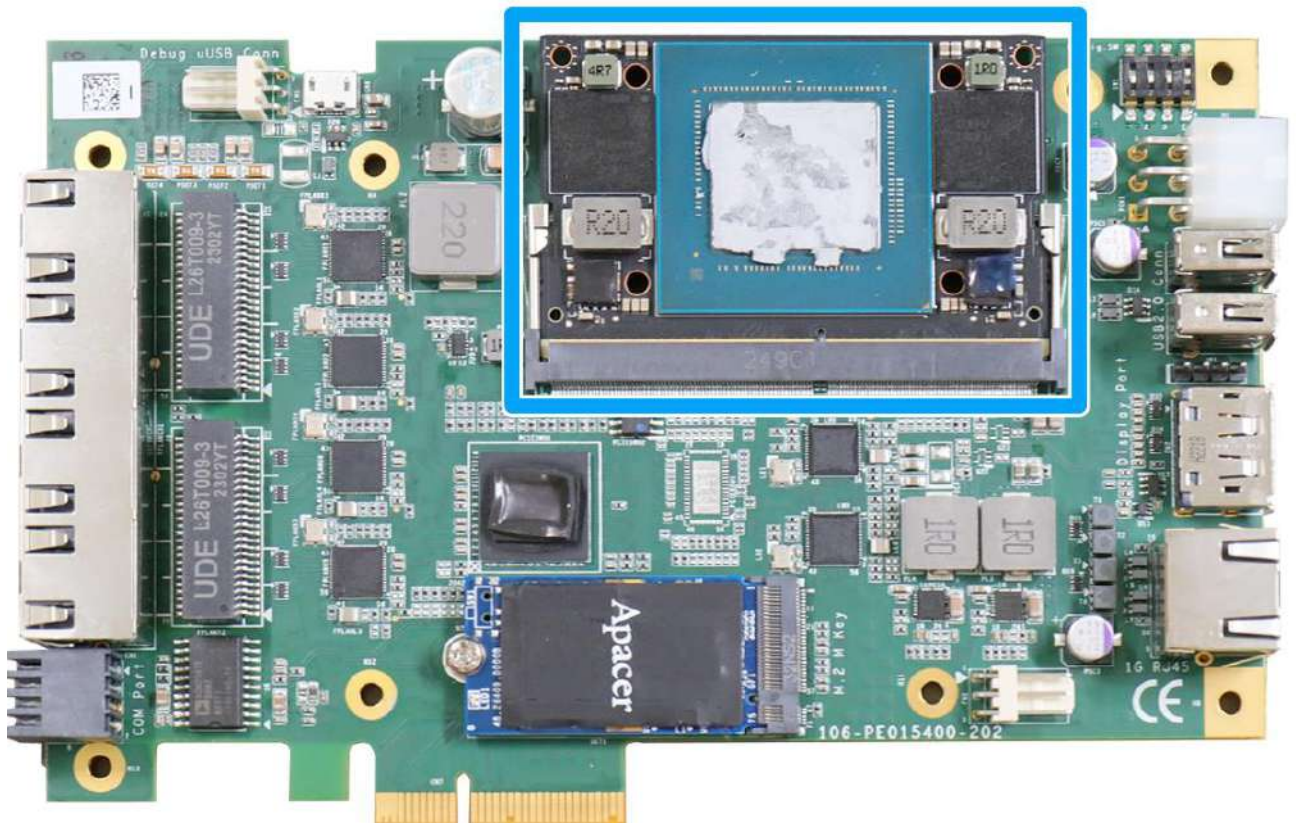

The system features a dedicated slot for NVIDIA Jetson Orin NX module .



### NOTE

*If your system came with an NVIDIA Jetson Orin NX preinstalled, the thermal pad protection film (for the SoM and NVMe SSD) at the bottom of the heatsink will be removed during the factory installation process.*

## 2.6 Onboard M.2 2242 M Key Slot for NVMe SSD

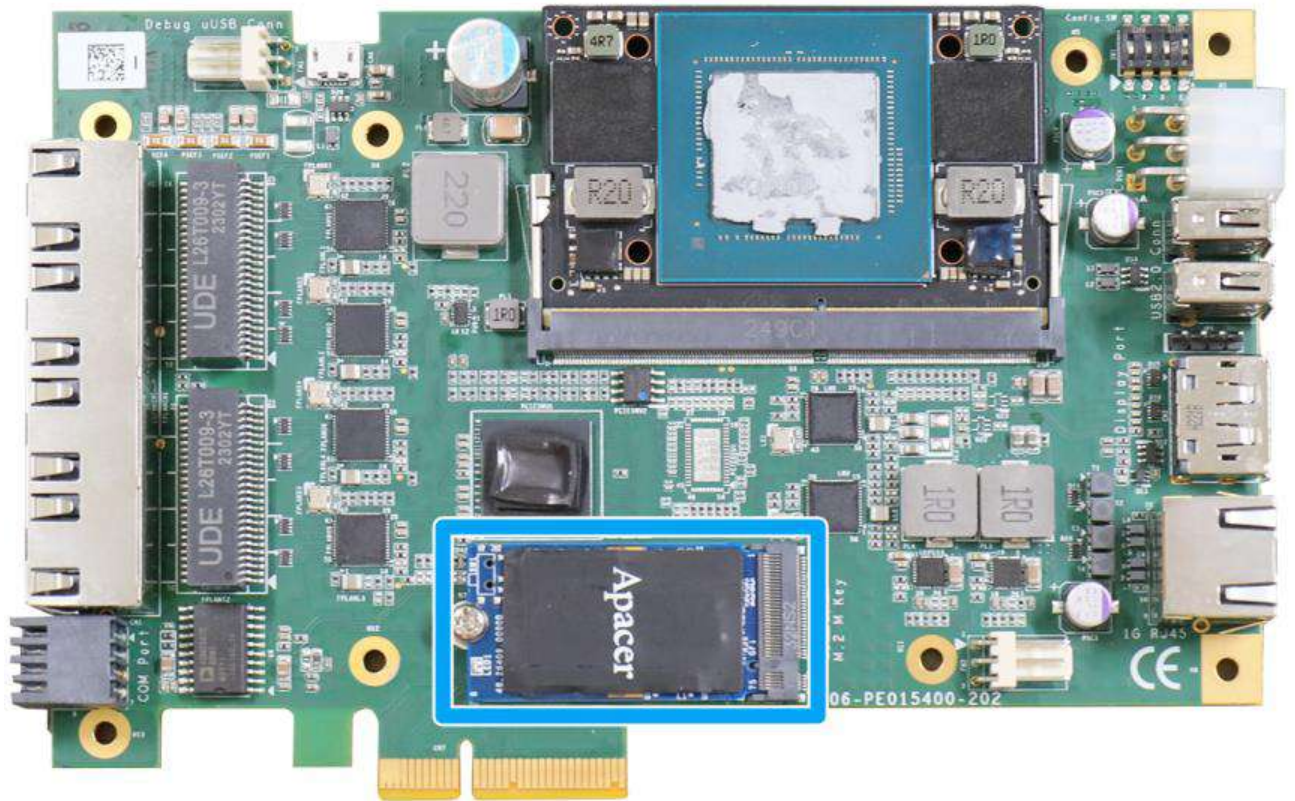

The system has a Gen3 x1 PCIe M.2 2242 slot for you to install an NVMe SSD. The M.2 NVMe SSD offers significantly better system performances when compared to a 2.5" SSD.



### NOTE

*If your system came with an NVIDIA Jetson Orin NX preinstalled, the thermal pad protection film (for the SoM and NVMe SSD) at the bottom of the heatsink will be removed during the factory installation process.*



## 2.7 DIP Switch

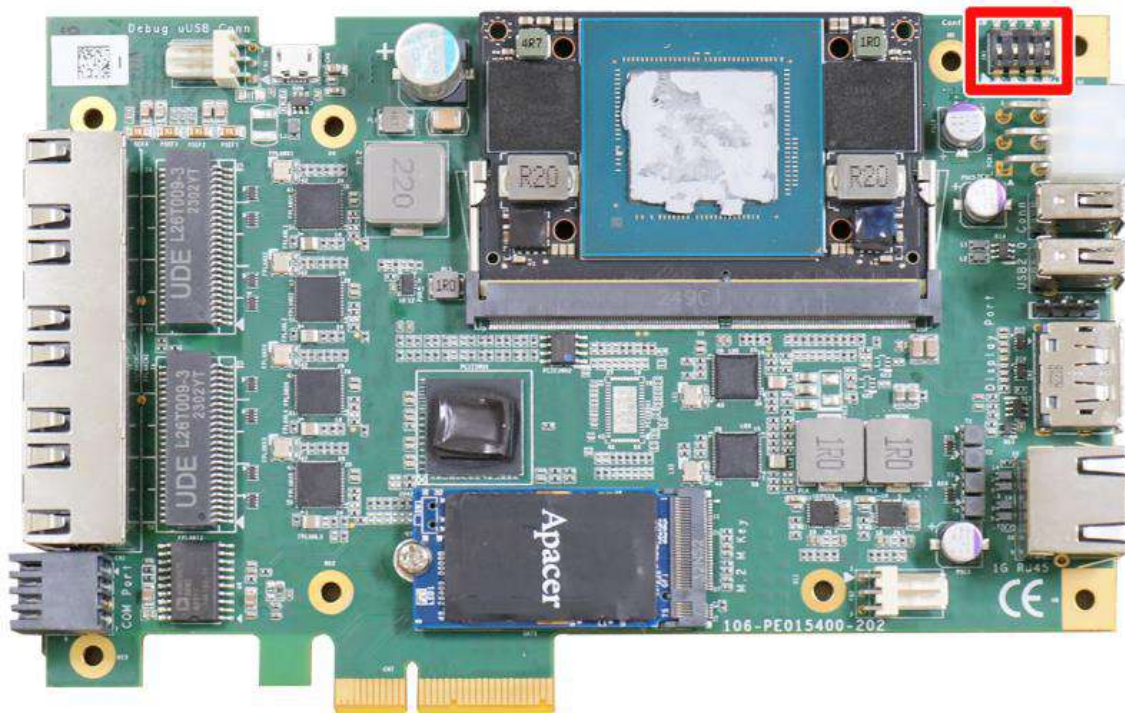

The frame grabber card has a DIP switch (indicated in red) on the top right corner of the card. By configuring the DIP 1/2 switches, you can manually set the default IP of the card (NX side), allowing up to four cards to be installed into the same host computer. For DIP switch settings, please refer to the table on the right:

DIP 1/ DIP 2	NX Side IP	Host Side IP
	150.150.50.50	150.150.50.51
	150.150.51.50	150.150.51.51
	150.150.52.50	150.150.52.51
	150.150.53.50	150.150.53.51

DIP Switch	Off	On
1	Board ID, High Bit = 0	Board ID, High Bit = 1
2	Board ID, Low Bit = 0	Board ID, Low Bit = 1
3	Boots into OS	Boots in recovery mode
4	Power by PCIe	Power by 6-pin (12V) input

## 3 System Installation

Before disassembling the system enclosure and installing the card, please read the following instructions:

- **DO NOT** remove the card out of the anti-static until you are ready to install it into the system.
- It is recommended that only qualified service personnel should install and service this product to avoid injury or damage to the system.
- Please observe all ESD procedures at all times to avoid damaging the equipment.
- Before disassembling your system, please make sure the system has powered off, all cables and antennae (power, video, data, etc.) are disconnected.
- Place the system on a flat and sturdy surface (remove from mounts or out of server cabinets) before proceeding with the installation/ replacement procedure.

### 3.1 System Disassembly

1. Remove the screws indicated on top and bottom of the onboard system connectivity end.



**Top screw**



**Bottom screws**

2. Remove the onboard system connection panel.



3. Remove the screws indicated and gently remove the flattop heatsink and PCB board out of the enclosure.

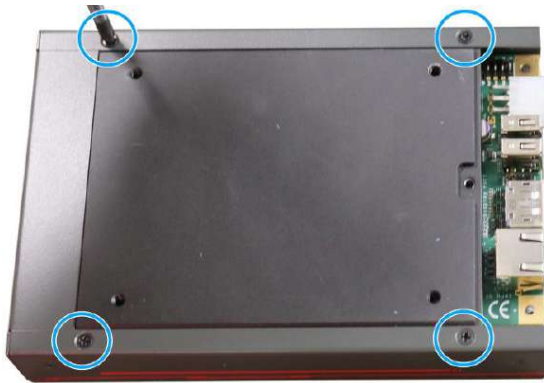

**Screws holding the flattop heatsink with enclosure**

**Remove from enclosure**

4. Remove the screws on the back of the PCB board.

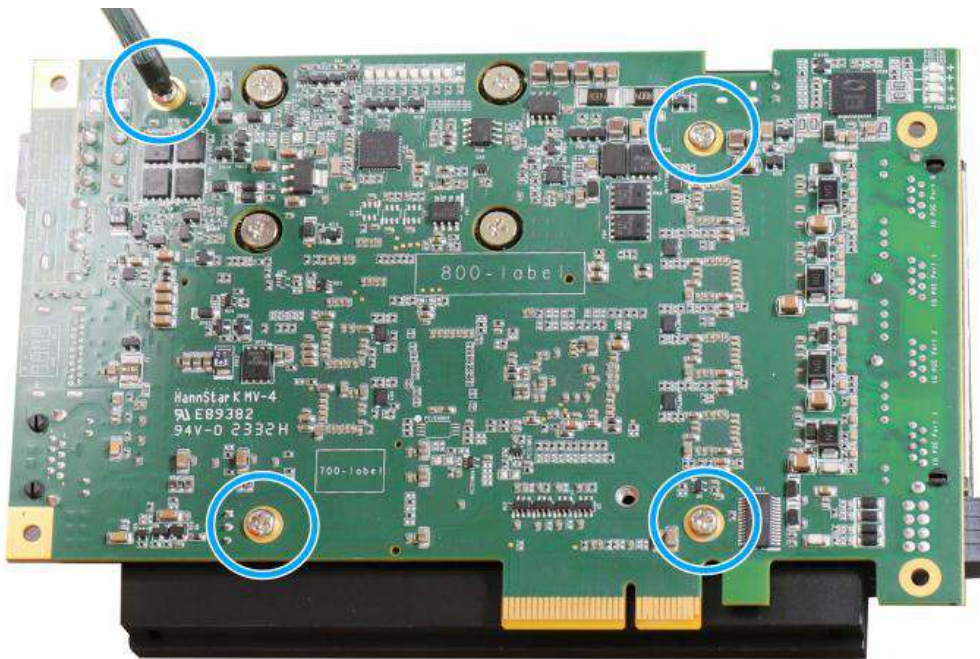

5. Separate the flattop heatsink from the PCB to gain access to the Jetson SoM and M.2 expansion slot.

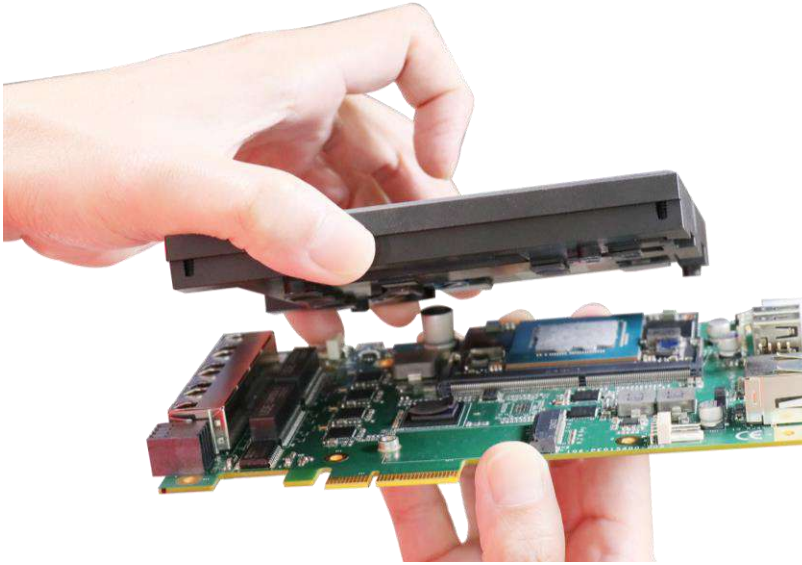



## 3.2 NVIDIA Jetson SoM

To NVIDIA Jetson Orin NX system on module (SoM) should already be installed in your system. Should you need to uninstall/ install the SoM, please refer to the following instructions:

1. Please refer to [System Disassembly](#) to gain access to internal components.
2. Turn the PCB board upside-down, and remove the screws indicated.

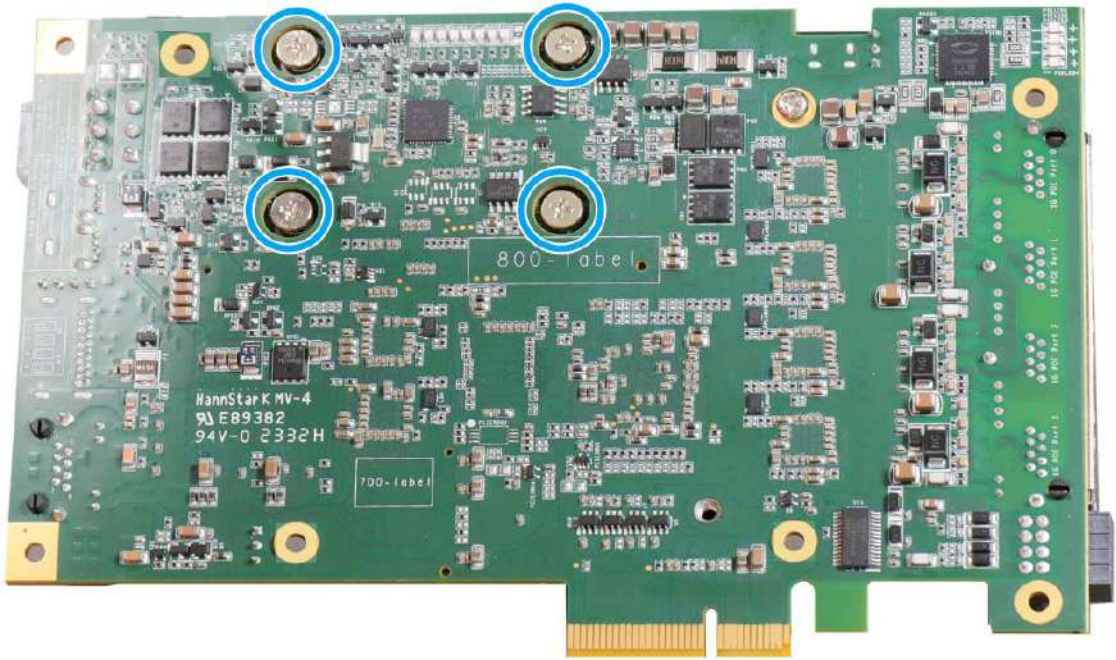

3. Turn the PCB board back around and push the two retaining clips on the side outward and the SoM should lift away from the PCB automatically.

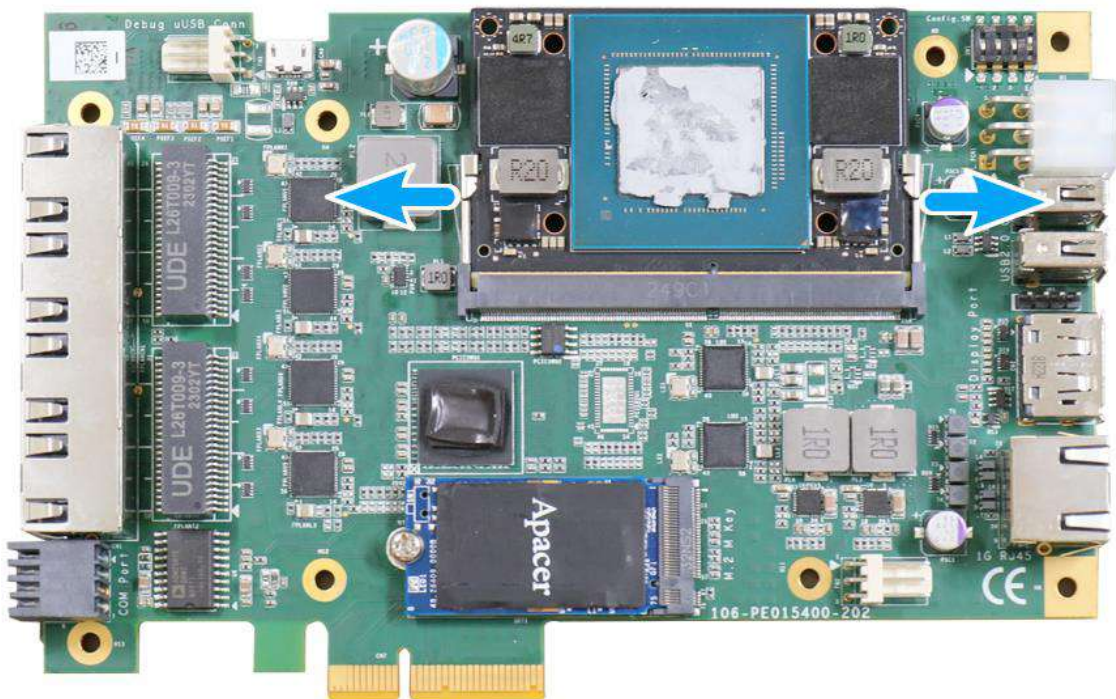



4. Remove the SoM and insert the new SoM into the slot on a 45-degree angle. Gently press the SoM module towards the PCB until the retaining clips click onto the SoM.

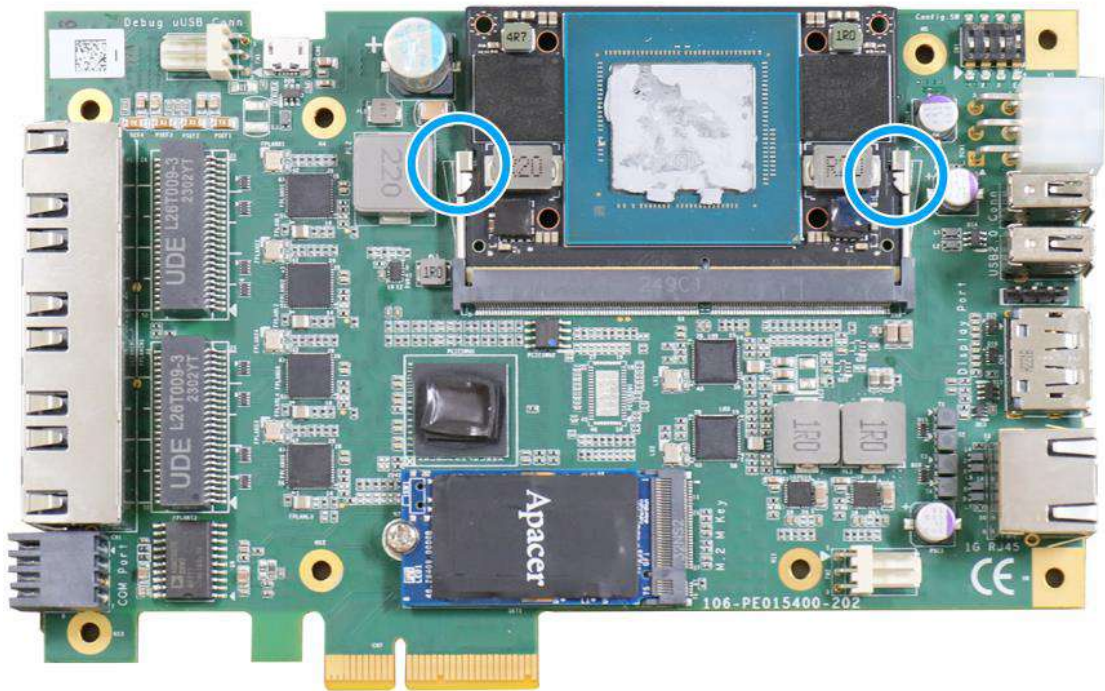

5. [Reinstall the system](#) when done. For other installation procedures, please refer to respective sections.

### 3.3 M.2 2242 M Key NVMe SSD Installation

To install the M.2 2242 M key NVMe SSD, please refer to the following instructions:

1. To remove the heatsink, please refer to [System Disassembly](#).
2. Insert the M.2 2242 NVMe SSD on a 45-degree angle into the slot.

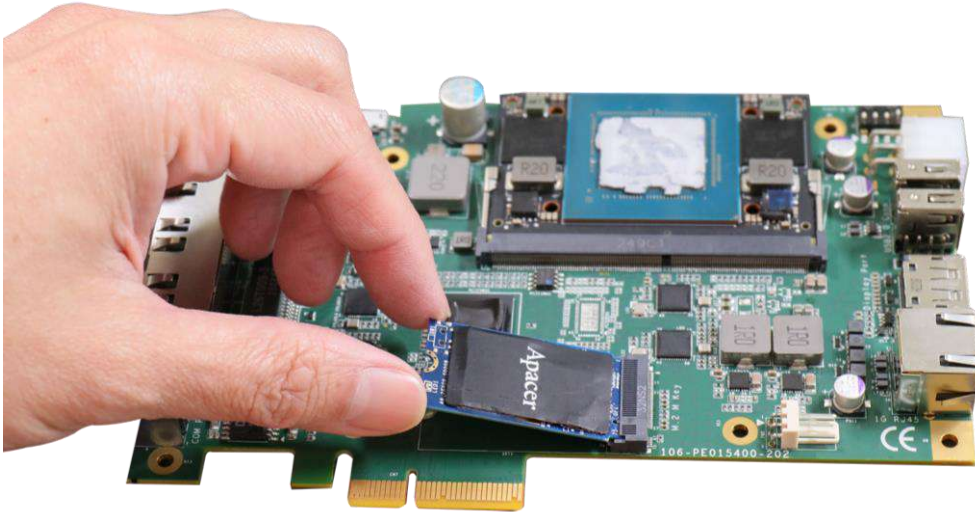

3. Press the SSD down and secure it with a screw.

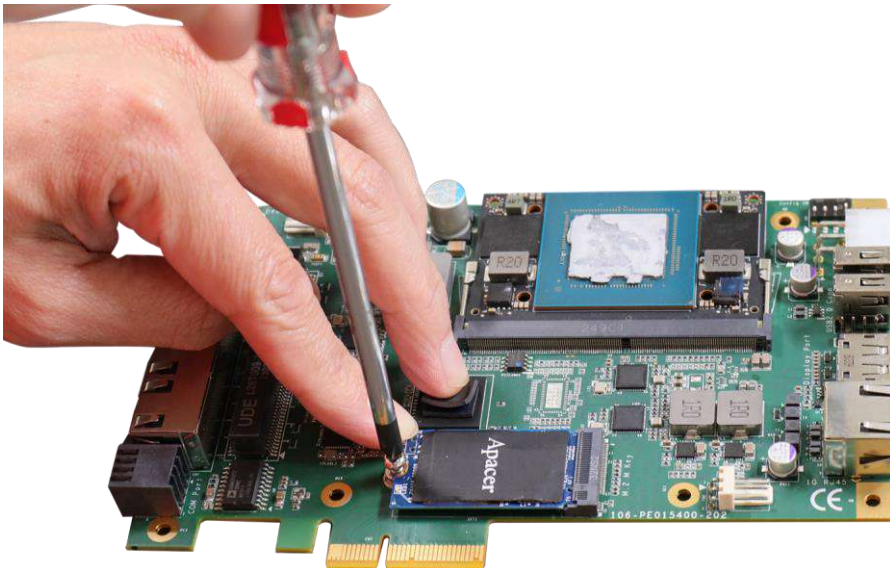

4. Remove the thermal pad protective film at the bottom of the heatsink.
5. [Reinstall the system](#) when done. For other installation procedures, please refer to respective sections.

### 3.4 Reinstalling the Enclosure

1. Place the heatsink back onto the PCB board, and turn them upside-down.



2. Secure the screws indicated to complete the heatsink installation process.

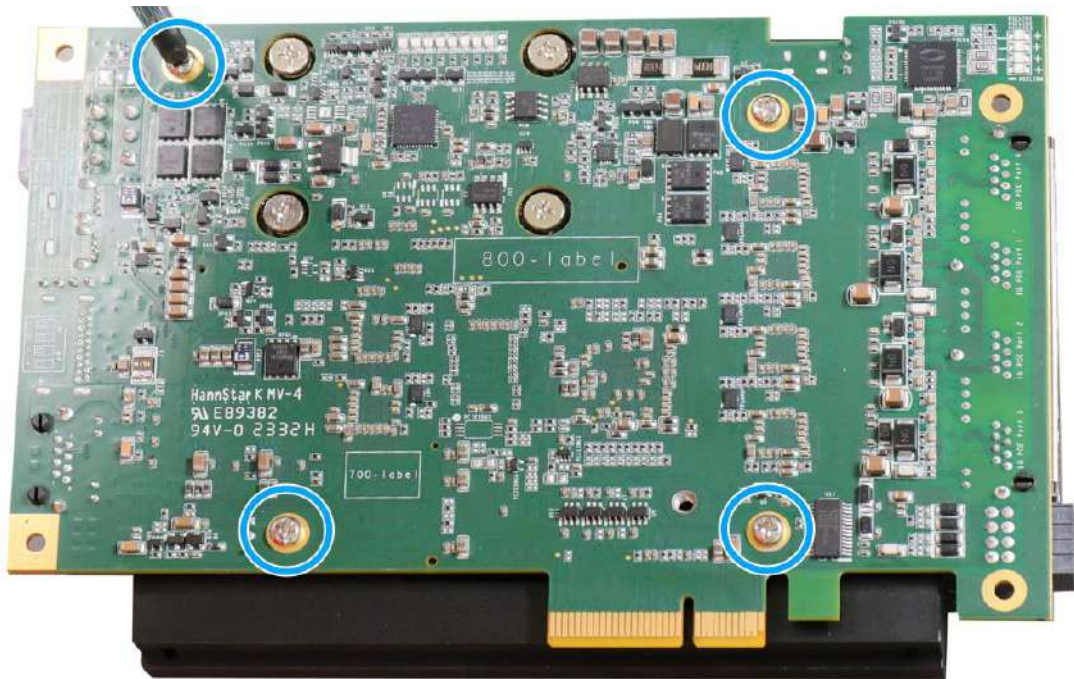



3. Insert the PCB/ heatsink back into the enclosure



4. Secure the screws indicated.

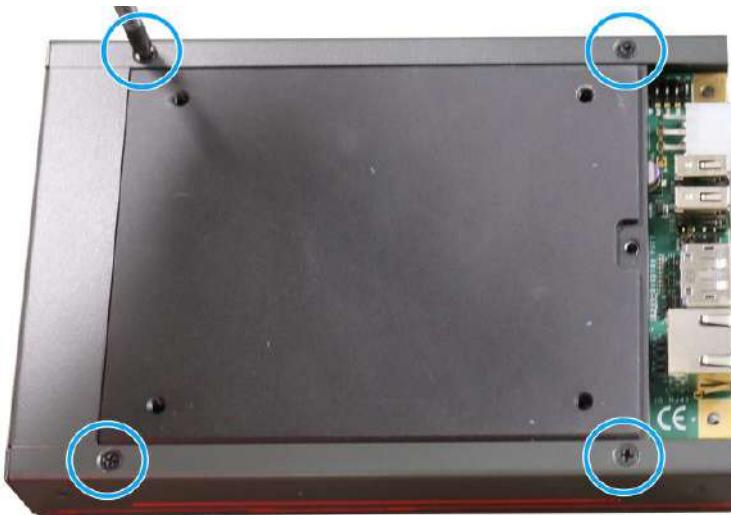

5. Attach the onboard system connection panel back onto the enclosure.



- Secure the screws on top and bottom of the onboard system connection end to complete the enclosure installation process.



### 3.5 Installing NRU-15x-FT into Enclosure



*NRU-15x-FT can be installed on the inside wall of the splash/ explosion/ proof boxes or junction enclosures as long as its flattop heatsink is placed on a flat surface and making full contact with a metallic surface.*

To install the NRU-15x-FT onto the host computer, please refer to the following instructions:

1. Take the bracket and screw set out of the accessory box, and install them onto the NRU-15x-FT system.

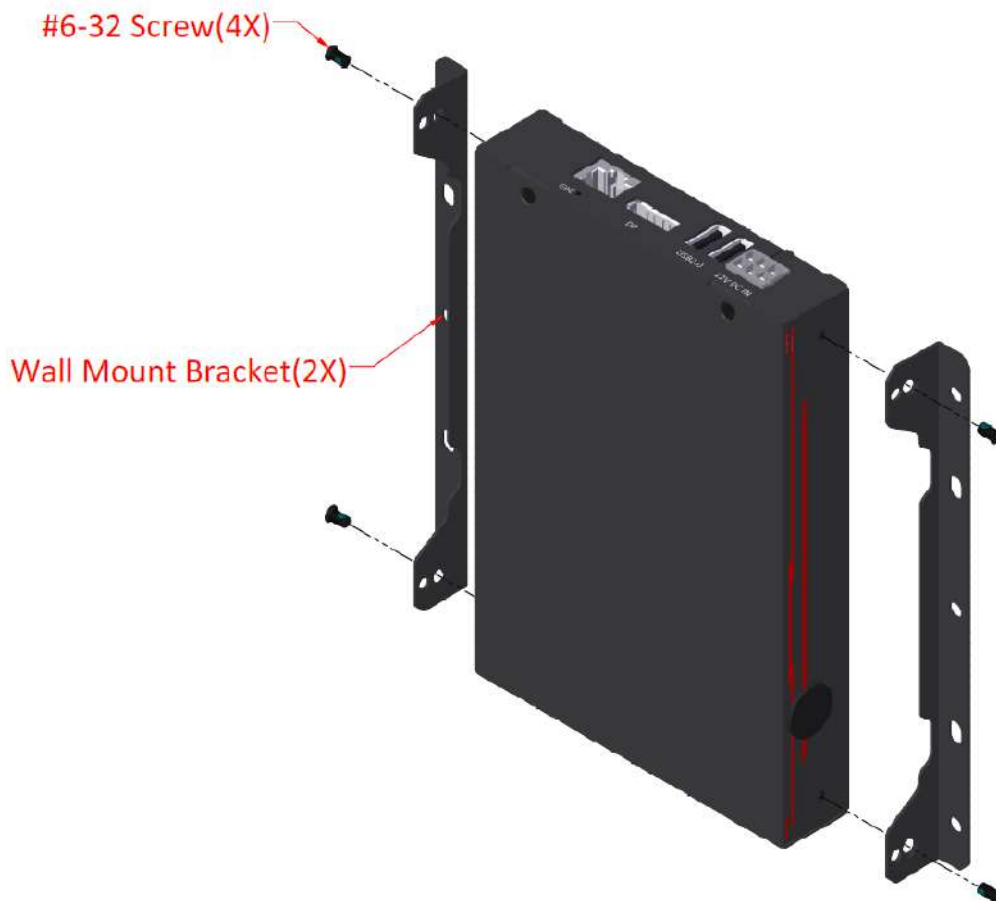

2. Secure the system onto the wall of the enclosure while making sure the flattop heatsink side makes full contact.

## 4 Reflashing the NRU-15x-FT

NRU-15x\_FT is shipped with JetPack 5.x installed as a turnkey solution. If you are familiar and experienced with the platform, you can skip this section and start your development.

This section will show you how to reflash the system with a pre-built system image by Neosys. Just like Jetson Orin NX Developer Kit, the NRU-15x-FT series can't install its system by itself. In other words, you will need another computer, **Host Machine**, to reflash the NRU-15x-FT via a microUSB to USB type A cable.

For detailed reflash process procedure, please refer to this [link](#).