

Neosys Technology Inc.

Nuvo-10000

User Manual

Revision 1.2

Table of Contents

Table of Contents	2
Legal Information	4
Contact Information	5
Declaration of Conformity	5
Copyright Notice	6
Safety Precautions	7
Service and Maintenance	8
ESD Precautions	8
About This Manual	9

1 Introduction

1.1 Product Specifications.....	11
1.1.1 Nuvo-10003 Specifications	11
1.1.2 Nuvo-10007 Specifications	14
1.1.3 Nuvo-10034 Specifications	17
1.2 Nuvo-10003 Dimensions	20
1.2.1 Nuvo-10003 I/O Panel View	20
1.2.2 Nuvo-10003 Side View	21
1.2.3 Nuvo-10003 Bottom View	21
1.3 Nuvo-10007/ 10034 Dimension	22
1.3.1 Nuvo-10007/ 10034 I/O Panel View	22
1.3.2 Nuvo-10007/ 10034 Side View.....	23
1.3.3 Nuvo-10007/ 10034 Bottom View	23

2 Overview

2.1 Nuvo-10000 Packing List	24
2.2 Nuvo-10000 Series I/O Panel	25
2.2.1 Reset Button	27
2.2.2 Power Button	28
2.2.3 3.5mm Speaker/ Headphone Output Jack	29
2.2.4 HDMI Port	30
2.2.5 DisplayPort.....	31
2.2.6 USB3.2 Gen2x1	32
2.2.7 LED Indicators	33
2.2.8 Gigabit Ethernet Port	34
2.2.9 2.5G Ethernet Port	35
2.2.10 USB3.2 Gen1x1 Port	36
2.2.11 Clear CMOS Button	37
2.2.12 COM2 Port	38
2.2.13 COM1 Port	39
2.2.14 3-pin Terminal Block for DC Input	40
2.2.15 COM3/ 4/ 5 Port	41
2.3 Internal I/O Functions.....	42
2.3.1 SODIMM DRAM Slot	42
2.3.2 mini-PCIe Slot & Pin Definition.....	43
2.3.3 M.2 2280 M Key Slot (SATA Signal Only)	45
2.3.4 SATA Ports	47
2.3.5 On/ Off Ctrl & Status Output.....	48
2.3.6 4-Pin Power Connector	50
2.3.7 8-pin Connector for GPU (up to 115W)	51
2.3.8 Internal USB.....	52

3 System Installation

3.1 Disassembling the System	54
3.2 Installing Internal Components	56

3.2.1	CPU Installation for Barebone System.....	56
3.2.2	Remove and Replace the Existing CPU	64
3.2.3	DDR5 SO-DIMM Installation	71
3.2.4	M.2 2280 M Key SATA SSD Installation.....	73
3.2.5	mini-PCIe slot, Mini-SIM (2FF) Card and Antenna Installation	75
3.2.6	HDD/ SSD Installation.....	77
3.2.7	On/ Off Control & Status LED Cable Installation (Optional)	79
3.3	Installing the System Enclosure	81
3.4	Wall-mount Bracket Installation	83
3.5	Powering On the System	84
3.5.1	Powering On Using the Power Button.....	84
3.5.2	Powering On Using Wake-on-LAN.....	85
3.5.3	Configure your Windows system.....	87

4 System Configuration

4.1	BIOS Settings	88
4.1.1	COM Port Configuration.....	89
4.1.2	COM Port High Speed Mode	90
4.1.3	Delay for PEG Initialization	91
4.1.4	Fan Control Configuration.....	92
4.1.5	Power On After Power Failure Option	96
4.1.6	Power & Performance (CPU SKU Power Configuration)	97
4.1.7	Wake on LAN Option	98
4.1.8	Boot Menu	99
4.1.9	Add Boot Options.....	101
4.1.10	Watchdog Timer for Booting.....	102
4.2	AMT Configuration	103
4.3	RAID Configuration	106
4.3.1	Enabling Volume Management Device (VMD) for RAID Volume Setup	106
4.3.2	RAID Volume Setup	108
4.3.3	Loading RAID Driver for Windows Installation	115

5 OS Support and Driver Installation

5.1	Operating System Compatibility	118
5.2	Driver Installation	119
5.3	Driver Installation for Watchdog Timer Control	119

Appendix A Using WDT & DIO

WDT and DIO Library Installation	121
WDT Functions.....	122
InitWDT	122
SetWDT	123
StartWDT	123
ResetWDT	124
StopWDT	124

Legal Information

All Neosys Technology Inc. products shall be subject to the latest Standard Warranty Policy

Neosys Technology Inc. may modify, update or upgrade the software, firmware or any accompanying user documentation without any prior notice. Neosys Technology Inc. will provide access to these new software, firmware or documentation releases from download sections of our website or through our service partners.

Before installing any software, applications or components provided by a third party, customer should ensure that they are compatible and interoperable with Neosys Technology Inc. product by checking in advance with Neosys Technology Inc.. Customer is solely responsible for ensuring the compatibility and interoperability of the third party's products. Customer is further solely responsible for ensuring its systems, software, and data are adequately backed up as a precaution against possible failures, alternation, or loss.

For questions in regards to hardware/ software compatibility, customers should contact Neosys Technology Inc. sales representative or technical support.

To the extent permitted by applicable laws, Neosys Technology Inc. shall NOT be responsible for any interoperability or compatibility issues that may arise when (1) products, software, or options not certified and supported; (2) configurations not certified and supported are used; (3) parts intended for one system is installed in another system of different make or model.

Contact Information

**Headquarters
(Taipei, Taiwan)**

Neosys Technology Inc.
15F, No.868-3, Zhongzheng Rd., Zhonghe Dist., New Taipei City, 23586, Taiwan
Tel: +886-2-2223-6182 Fax: +886-2-2223-6183 [Email](#), [Website](#)

**Americas
(Illinois, USA)**

Neosys Technology America Inc.
3384 Commercial Avenue, Northbrook, IL 60062, USA
Tel: +1-847-656-3298 [Email](#), [Website](#)

China

Neosys Technology (China) Ltd.
Room 612, Building 32, Guiping Road 6100, Shanghai
Tel: +86-2161155366 [Email](#), [Website](#)

Declaration of Conformity

FCC

This equipment has been tested and found to comply with the limits for a Class A digital device, pursuant to part 15 of the FCC Rules. These limits are designed to provide reasonable protection against harmful interference when the equipment is operated in a commercial environment. This equipment generates, uses, and can radiate radio frequency energy and, if not installed and used in accordance with the instruction manual, may cause harmful interference to radio communications. Operation of this equipment in a residential area is likely to cause harmful interference in which case the user will be required to correct the interference at own expense.

CE

The product(s) described in this manual complies with all applicable European Union (CE) directives if it has a CE marking. For computer systems to remain CE compliant, only CE-compliant parts may be used. Maintaining CE compliance also requires proper cable and cabling techniques.

Copyright Notice

All rights reserved. This publication may not be reproduced, transmitted, transcribed, stored in a retrieval system, or translated into any language or computer language, in any form or by any means, electronic, mechanical, magnetic, optical, chemical, manual or otherwise, without the prior written consent of Neousys Technology, Inc.

Disclaimer

This manual is intended to be used as an informative guide only and is subject to change without prior notice. It does not represent commitment from Neousys Technology Inc. Neousys Technology Inc. shall not be liable for any direct, indirect, special, incidental, or consequential damages arising from the use of the product or documentation, nor for any infringement on third party rights.

Patents and Trademarks

Neousys, the Neousys logo, Expansion Cassette, MezIO™ are registered patents and trademarks of Neousys Technology, Inc.

Windows is a registered trademark of Microsoft Corporation.

Intel®, Core™ are registered trademarks of Intel Corporation

NVIDIA® is a registered trademark of NVIDIA Corporation

All other names, brands, products or services are trademarks or registered trademarks of their respective owners.

Safety Precautions

- Read these instructions carefully before you install, operate, or transport the system.
- Install the system or DIN rail associated with, at a sturdy location
- Install the power socket outlet near the system where it is easily accessible
- Secure each system module(s) using its retaining screws
- Place power cords and other connection cables away from foot traffic. Do not place items over power cords and make sure they do not rest against data cables
- Shutdown, disconnect all cables from the system and ground yourself before touching internal modules
- Ensure that the correct power range is being used before powering the device
- Should a module fail, arrange for a replacement as soon as possible to minimize down-time
- If the system is not going to be used for a long time, disconnect it from mains (power socket) to avoid transient over-voltage

Service and Maintenance

- ONLY qualified personnel should service the system
- Shutdown the system, disconnect the power cord and all other connections before servicing the system
- When replacing/ installing additional components (expansion card, memory module, etc.), insert them as gently as possible while assuring proper connector engagement

ESD Precautions

- Handle add-on module, motherboard by their retention screws or the module's frame/ heat sink. Avoid touching the PCB circuit board or add-on module connector pins
- Use a grounded wrist strap and an anti-static work pad to discharge static electricity when installing or maintaining the system
- Avoid dust, debris, carpets, plastic, vinyl and styrofoam in your work area.
- Do not remove any module or component from its anti-static bag before installation

About This Manual

This manual introduces Neosys Nuvo-10000 Series featuring Intel® 14th/ 13th /12th Gen Core™ 65W/ 35W processors with up to 7 slot expandability. The system is capable of supporting one 115W NVIDIA® graphics card for modern AI applications.

The guide also demonstrates the system's installation procedures.

Revision History

Version	Date	Description
1.0	Apr. 2024	Initial release
1.1	May. 2024	Updated the required DC input voltage when the system is operating under certain power load
1.2	Jul. 2024	Added On/Off Control Status pin number illustration on I/O panel

1 Introduction

Nuvo-10000 series is the ideal choice to replace your bulky rack-mount or wall-mount IPC systems. The system offers up to seven PCIe/ PCI slots in its compact chassis to deliver the same level of expandability as off-the-shelf 4U 19" IPCs. Users can install a wide variety of AIO, DIO, communication, image capture and motion control cards for versatile applications.



Leveraging Intel® 14th/ 13th/ 12th-Gen Alder Lake Core™ i desktop processors with Q670 chipset, Nuvo-10000 series delivers exceptional computing power over traditional IPCs in a comparatively compact size with a competitive price. It features eight USB 3.2 ports with screw-lock mechanism for USB3 cameras. There is one GbE, one 2.5 GbE, 5 COM ports, and accommodates two 2.5" HDDs/ SSDs with the addition of an internal SATA port for a third HDD/SSD. The system can also support a 115W NVIDIA® GPU to offer significant AI computing power for modern deep-learning applications.

Driven by the increasing demand for industrial IoT, vision inspection and machine automation, Nuvo-10000 series is a flexible all-around rugged solution that can satisfy various industrial applications. With an assortment of I/O ports and flexible 7-slot PCIe/ PCI expandability, Nuvo-10000 series is geared for the fifth industrial revolution.

1.1 Product Specifications

1.1.1 Nuvo-10003 Specifications

System Core	
Processor	Supporting Intel® 14th-Gen Core™ CPU (LGA1700 socket, 65W/ 35W TDP) - Intel® Core™ i9-14900/ i9-14900T - Intel® Core™ i7-14700/ i7-14700T - Intel® Core™ i5-14500/ i5-14400/ i5-14500T - Intel® Core™ i3-14100/ i3-14100T
	Supporting Intel® 13th-Gen Core™ CPU (LGA1700 socket, 65W/ 35W TDP) - Intel® Core™ i9-13900E/ i9-13900TE - Intel® Core™ i7-13700E/ i7-13700TE - Intel® Core™ i5-13500E/ i5-13400E/ i5-13500TE - Intel® Core™ i3-13100E/ i3-13100TE
	Supporting Intel® 12th-Gen Core™ CPU (LGA1700 socket, 35W/ 65W TDP) - Intel® Core™ i9-12900E/ i9-12900TE - Intel® Core™ i7-12700E/ i7-12700TE - Intel® Core™ i5-12500E/ i5-12500TE - Intel® Core™ i3-12100E/ i3-12100TE - Intel® Pentium® G7400E/ G7400TE - Intel® Celeron® G6900E/ G6900TE
Chipset	Intel® Q670E platform controller hub
Graphics	Integrated Intel® UHD Graphics 770 (32EU)/ 730 (24EU)
Memory	Up to 64 GB DDR5 4800 SDRAM (two SODIMM slots)
AMT	Supports Intel vPro/ AMT 16.0
TPM	Supports dTPM2.0
I/O Interface	
Ethernet	1x 2.5G Ethernet port by I226-IT 1x Gigabit Ethernet port by I219-LM
Video port	1x HDMI 1.4b, supporting 3840 x 2160 resolution 1x DisplayPort, supporting 4096 x 2304 resolution
Serial Port	2x software-programmable RS-232/422/485 ports (COM1/ COM2) 3x 3-wire RS-232 ports (COM3/ COM4/ COM5)
USB3.2	4x USB 3.2 Gen2 (10 Gbps) ports

	4x USB 3.2 Gen2 (5 Gbps) ports
USB2.0	1x USB 2.0 port with Type-A connector (internal)
Audio	1x 3.5mm jack for mic-in and speaker-out
Storage Interface	
SATA	2x SATA ports for internal 2.5" HDD/ SSD installation
M.2	1x M.2 2280 SATA interface
Expansion Bus	
PCI Express	1x PCIe x16 slot @ Gen3, 16-lanes 2x PCIe x8 slot @ Gen3, 4-lanes
mini PCIe	2x full-size mini PCI Express socket
Power Supply	
DC Input	1x 3-pin pluggable terminal block for 12V to 35V DC input *
Remote Ctrl. & LED Output	1x 10-pin (2x5) wafer connector for remote on/off control and status LED output
Max. power consumption	For reference only, actual consumption may vary depending on configuration. With i7-12700 (65W mode): 141.4W (Max.) @ 24V With i7-12700 (65W mode): 146.4W (Max.) @ 48V With i7-12700TE (35W mode): 106.6W (Max.) @ 24V With i7-12700TE (35W mode): 111.8W (Max.) @ 48V With i5-12400 (35W mode): 105.1W (Max.) @ 24V With i5-12400 (35W mode): 110.9W (Max.) @ 48V With i5-12400 (65W mode): 120.5W (Max.) @ 24V With i5-12400 (65W mode): 126.2W (Max.) @ 48V
Mechanical	
Dimension	157.1(W) x 280(D) x 188.3(H) mm (Nuvo-10003)
Weight	4.2kg
Mounting	Wall-mount (standard)
Environmental	
Operating temperature	-25°C to 60°C **
Storage temperature	-40°C to 85°C
Humidity	10% to 90%, non-condensing
Vibration	Operating, MIL-STD-810H, Method 514.6, Category 4
Shock	Operating, MIL-STD-810H, Method 516.6, Procedure I, Table 516.6-II
EMC	CE/ FCC Class A, according to EN 55032 & EN 55035

- * When system load is 150W or less, the required DC input range is 12V to 35V; when the system load is between 151W and 320W (with a GPU card), the required DC input is 24V to 35V.
- ** For sub-zero operating temperature, a wide temperature HDD or solid state disk (SSD) is required.

1.1.2 Nuvo-10007 Specifications

System Core	
Processor	Supporting Intel® 14th-Gen Core™ CPU (LGA1700 socket, 65W/ 35W TDP) <ul style="list-style-type: none"> - Intel® Core™ i9-14900/ i9-14900T - Intel® Core™ i7-14700/ i7-14700T - Intel® Core™ i5-14500/ i5-14400/ i5-14500T - Intel® Core™ i3-14100/ i3-14100T
	Supporting Intel® 13th-Gen Core™ CPU (LGA1700 socket, 65W/ 35W TDP) <ul style="list-style-type: none"> - Intel® Core™ i9-13900E/ i9-13900TE - Intel® Core™ i7-13700E/ i7-13700TE - Intel® Core™ i5-13500E/ i5-13400E/ i5-13500TE - Intel® Core™ i3-13100E/ i3-13100TE
	Supporting Intel® 12th-Gen Core™ CPU (LGA1700 socket, 35W/ 65W TDP) <ul style="list-style-type: none"> - Intel® Core™ i9-12900E/ i9-12900TE - Intel® Core™ i7-12700E/ i7-12700TE - Intel® Core™ i5-12500E/ i5-12500TE - Intel® Core™ i3-12100E/ i3-12100TE - Intel® Pentium® G7400E/ G7400TE - Intel® Celeron® G6900E/ G6900TE
Chipset	Intel® Q670E platform controller hub
Graphics	Integrated Intel® UHD Graphics 770 (32EU)/ 730 (24EU)
Memory	Up to 64 GB DDR5 4800 SDRAM (two SODIMM slots)
AMT	Supports Intel vPro/ AMT 16.0
TPM	Supports dTPM 2.0
I/O Interface	
Ethernet	1x 2.5G Ethernet port by I226-IT 1x Gigabit Ethernet port by I219-LM
Video port	1x HDMI 1.4b, supporting 3840 × 2160 resolution 1x DisplayPort, supporting 4096 x 2304 resolution
Serial Port	2x software-programmable RS-232/422/485 ports (COM1/ COM2) 3x 3-wire RS-232 ports (COM3/ COM4/ COM5)
USB3.2	4x USB 3.2 Gen2 (10 Gbps) ports

	4x USB 3.2 Gen2 (5 Gbps) ports
USB2.0	1x USB 2.0 port with Type-A connector (internal)
Audio	1x 3.5mm jack for mic-in and speaker-out
Storage Interface	
SATA	2x SATA ports for internal 2.5" HDD/ SSD installation
M.2	1x M.2 2280 SATA interface
Expansion Bus	
PCI Express	2x PCIe x16 slot @ Gen3, 8-lanes 3x PCIe x8 slot @ Gen3, 4-lanes 2x PCIe x4 slot @ Gen3, 2-lanes
mini PCIe	2x full-size mini PCI Express socket
Power Supply	
DC Input	1x 3-pin pluggable terminal block for 12V to 35V DC input
Remote Ctrl. & LED Output	1x 10-pin (2x5) wafer connector for remote on/off control and status LED output
Max. power consumption	For reference only, actual consumption may vary depending on configuration. With i7-12700 (65W mode): 141.4W (Max.) @ 24V With i7-12700 (65W mode): 146.4W (Max.) @ 48V With i7-12700TE (35W mode): 106.6W (Max.) @ 24V With i7-12700TE (35W mode): 111.8W (Max.) @ 48V With i5-12400 (35W mode): 105.1W (Max.) @ 24V With i5-12400 (35W mode): 110.9W (Max.) @ 48V With i5-12400 (65W mode): 120.5W (Max.) @ 24V With i5-12400 (65W mode): 126.2W (Max.) @ 48V
Mechanical	
Dimension	240.7(W) x 280(D) x 188.3(H) mm
Weight	5.2kg
Mounting	Wall-mount (standard)
Environmental	
Operating temperature	-25°C to 60°C
Storage temperature	-40°C to 85°C
Humidity	10% to 90%, non-condensing
Vibration	Operating, MIL-STD-810H, Method 514.6, Category 4
Shock	Operating, MIL-STD-810H, Method 516.6, Procedure I, Table 516.6-II
EMC	CE/ FCC Class A, according to EN 55032 & EN 55035

- * When system load is 150W or less, the required DC input range is 12V to 35V; when the system load is between 151W and 320W (with a GPU card), the required DC input is 24V to 35V.
- ** For sub-zero operating temperature, a wide temperature HDD or solid state disk (SSD) is required.

1.1.3 Nuvo-10034 Specifications

System Core	
Processor	Supporting Intel® 14th-Gen Core™ CPU (LGA1700 socket, 65W/ 35W TDP) - Intel® Core™ i9-14900/ i9-14900T - Intel® Core™ i7-14700/ i7-14700T - Intel® Core™ i5-14500/ i5-14400/ i5-14500T - Intel® Core™ i3-14100/ i3-14100T
	Supporting Intel® 13th-Gen Core™ CPU (LGA1700 socket, 65W/ 35W TDP) - Intel® Core™ i9-13900E/ i9-13900TE - Intel® Core™ i7-13700E/ i7-13700TE - Intel® Core™ i5-13500E/ i5-13400E/ i5-13500TE - Intel® Core™ i3-13100E/ i3-13100TE
	Supporting Intel® 12th-Gen Core™ CPU (LGA1700 socket, 35W/ 65W TDP) - Intel® Core™ i9-12900E/ i9-12900TE - Intel® Core™ i7-12700E/ i7-12700TE - Intel® Core™ i5-12500E/ i5-12500TE - Intel® Core™ i3-12100E/ i3-12100TE - Intel® Pentium® G7400E/ G7400TE - Intel® Celeron® G6900E/ G6900TE
Chipset	Intel® Q670E platform controller hub
Graphics	Integrated Intel® UHD Graphics 770 (32EU)/ 730 (24EU)
Memory	Up to 64 GB DDR5 4800 SDRAM (two SODIMM slots)
AMT	Supports Intel vPro/ AMT 16.0
TPM	Supports dTPM 2.0
I/O Interface	
Ethernet	1x 2.5G Ethernet port by I226-IT 1x Gigabit Ethernet port by I219-LM
Video port	1x HDMI 1.4b, supporting 3840 x 2160 resolution 1x DisplayPort, supporting 4096 x 2304 resolution
Serial Port	2x software-programmable RS-232/422/485 ports (COM1/ COM2) 3x 3-wire RS-232 ports (COM3/ COM4/ COM5)
USB3.2	4x USB 3.2 Gen2 (10 Gbps) ports 4x USB 3.2 Gen2 (5 Gbps) ports
USB2.0	1x USB 2.0 port with Type-A connector (internal)
Audio	1x 3.5mm jack for mic-in and speaker-out

Storage Interface	
SATA	2x SATA ports for internal 2.5" HDD/ SSD installation
M.2	1x M.2 2280 SATA interface
Expansion Bus	
PCI Express	2x PCIe x16 slot @ Gen3, 8-lanes 2x PCIe x8 slot @ Gen3, 4-lanes
mini PCIe	2x full-size mini PCI Express socket
Power Supply	
DC Input	1x 3-pin pluggable terminal block for 12V to 35V DC input
Remote Ctrl. & LED Output	1x 10-pin (2x5) wafer connector for remote on/off control and status LED output
Max. power consumption	For reference only, actual consumption may vary depending on configuration. With i7-12700 (65W mode): 141.4W (Max.) @ 24V With i7-12700 (65W mode): 146.4W (Max.) @ 48V With i7-12700TE (35W mode): 106.6W (Max.) @ 24V With i7-12700TE (35W mode): 111.8W (Max.) @ 48V With i5-12400 (35W mode): 105.1W (Max.) @ 24V With i5-12400 (35W mode): 110.9W (Max.) @ 48V With i5-12400 (65W mode): 120.5W (Max.) @ 24V With i5-12400 (65W mode): 126.2W (Max.) @ 48V
Mechanical	
Dimension	240.7(W) x 280(D) x 188.3(H) mm
Weight	5.2kg
Mounting	Wall-mount (standard)
Environmental	
Operating temperature	-25°C to 60°C
Storage temperature	-40°C to 85°C
Humidity	10% to 90%, non-condensing
Vibration	Operating, MIL-STD-810H, Method 514.6, Category 4
Shock	Operating, MIL-STD-810H, Method 516.6, Procedure I, Table 516.6-II
EMC	CE/ FCC Class A, according to EN 55032 & EN 55035

* When system load is 150W or less, the required DC input range is 12V to 35V; when the system load is between 151W and 320W (with a GPU card), the required DC input is 24V to 35V.

** For sub-zero operating temperature, a wide temperature HDD or solid state disk (SSD) is required.

1.2 Nuvo-10003 Dimensions

 NOTE

All measurements are in millimeters (mm).

1.2.1 Nuvo-10003 I/O Panel View

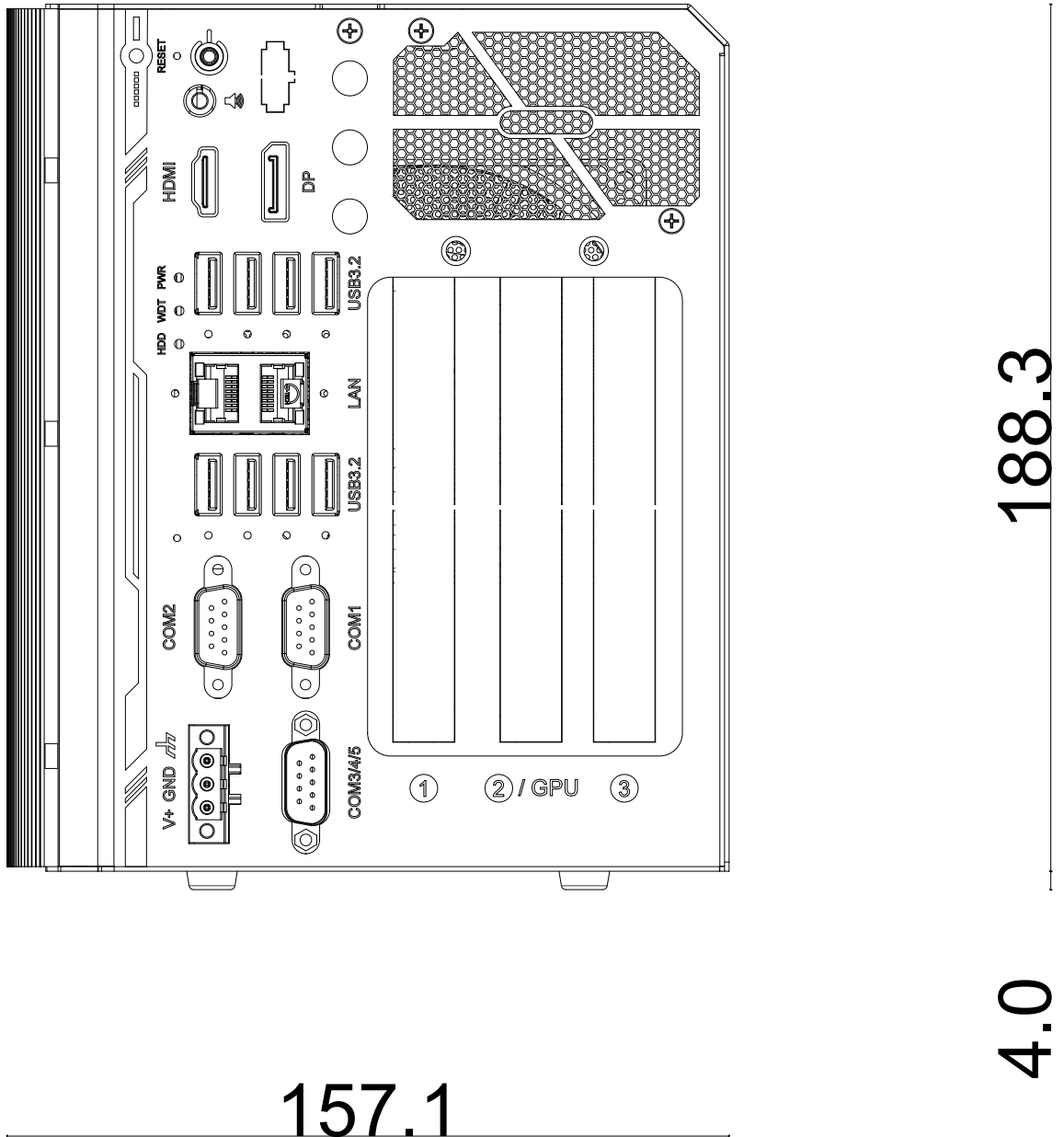

1.2.2 Nuvo-10003 Side View

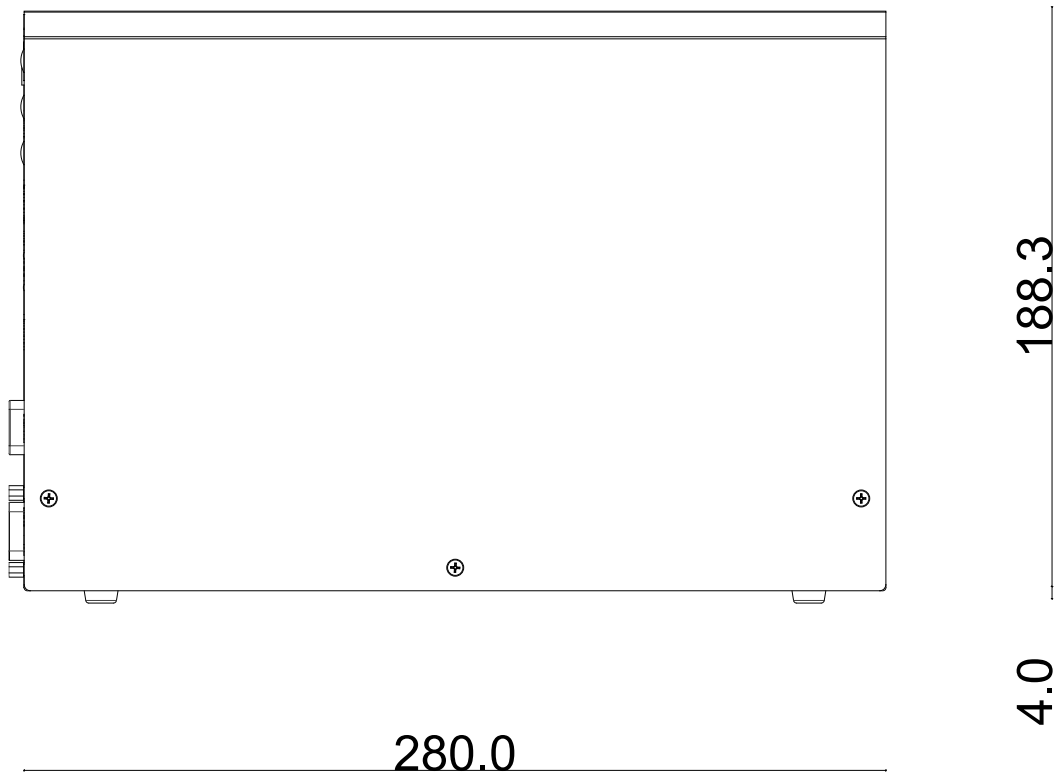

1.2.3 Nuvo-10003 Bottom View

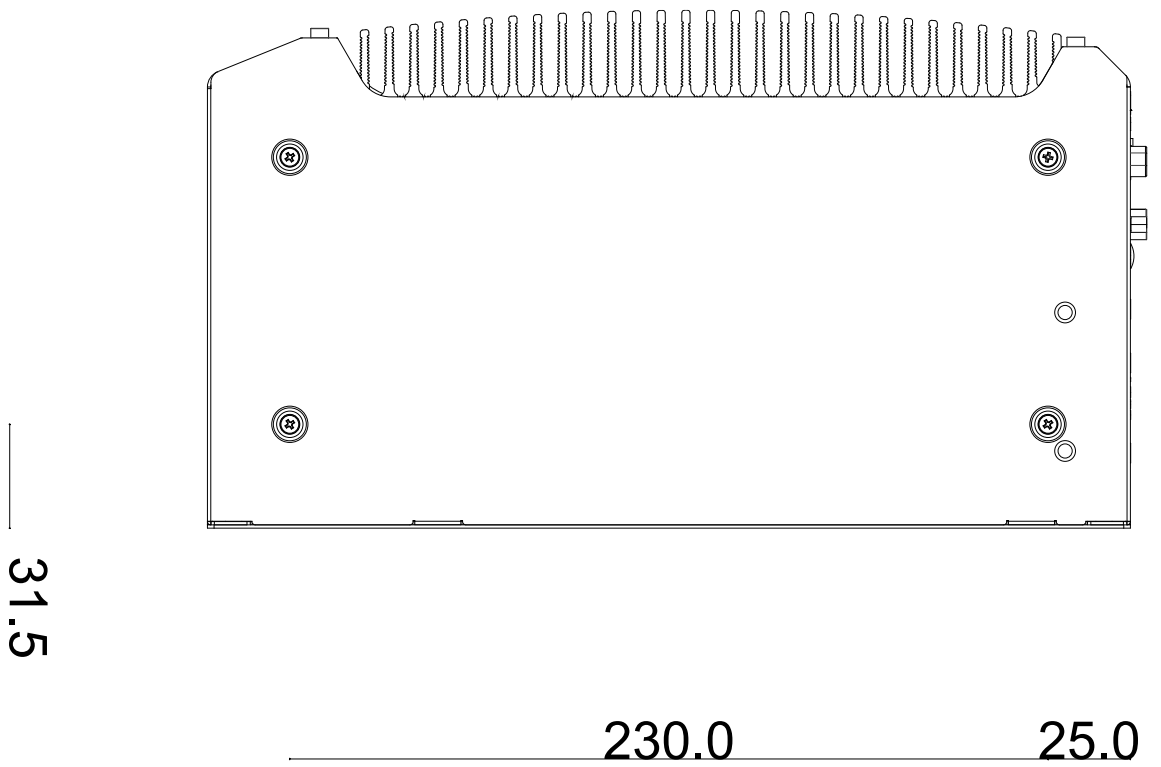

1.3 Nuvo-10007/ 10034 Dimension

 **NOTE**

Nuvo-10007/ 10034 systems share the same external dimensions.

All measurements are in millimeters (mm).

1.3.1 Nuvo-10007/ 10034 I/O Panel View

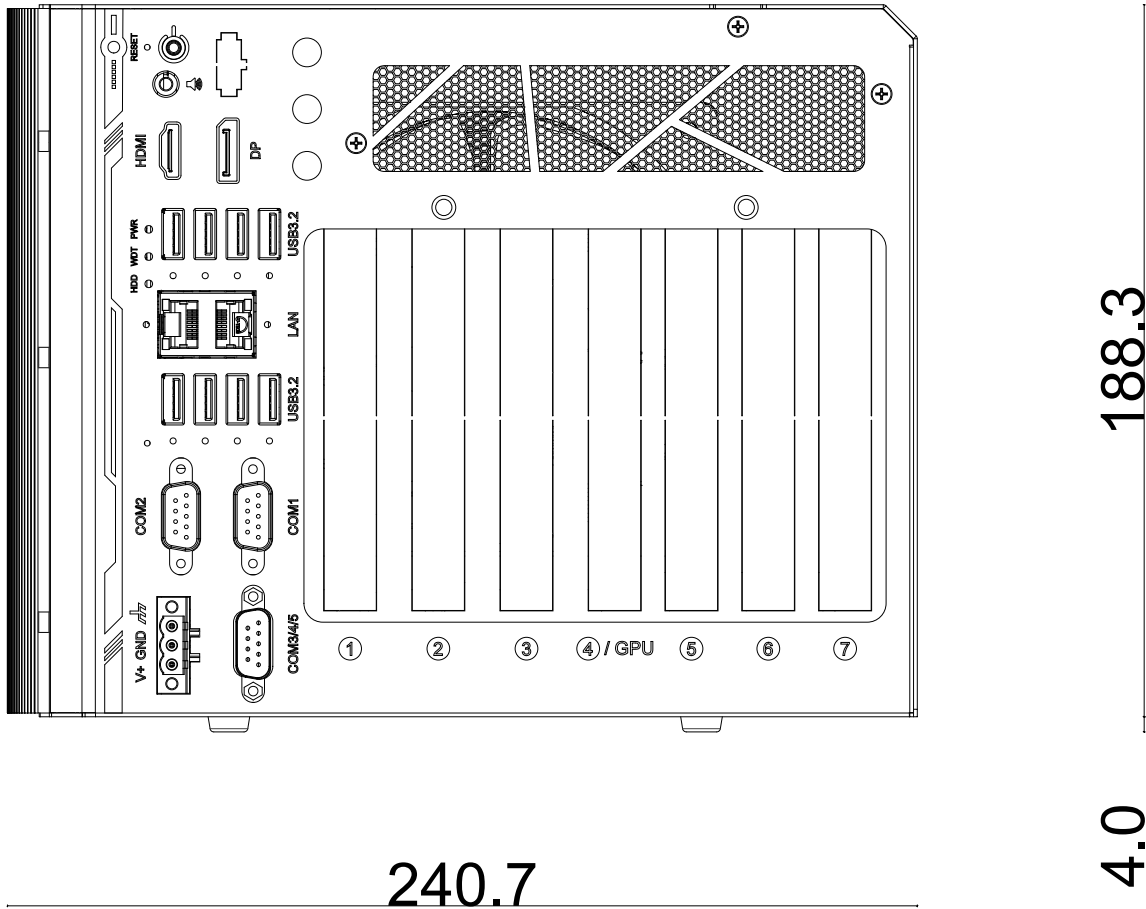

1.3.2 Nuvo-10007/ 10034 Side View

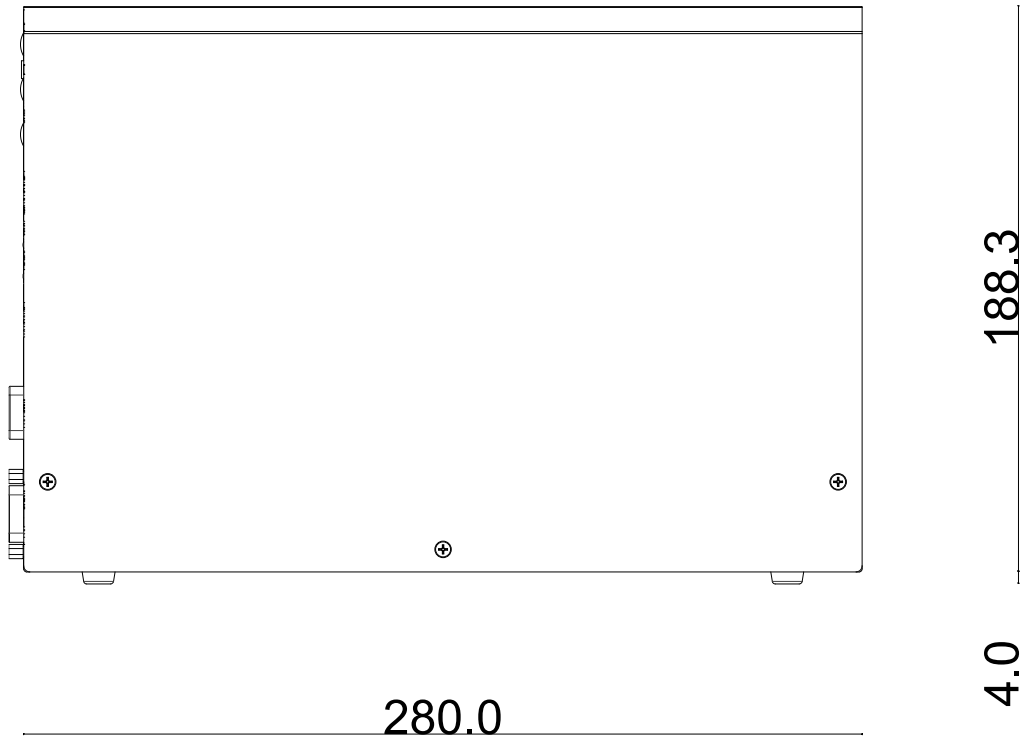

1.3.3 Nuvo-10007/ 10034 Bottom View

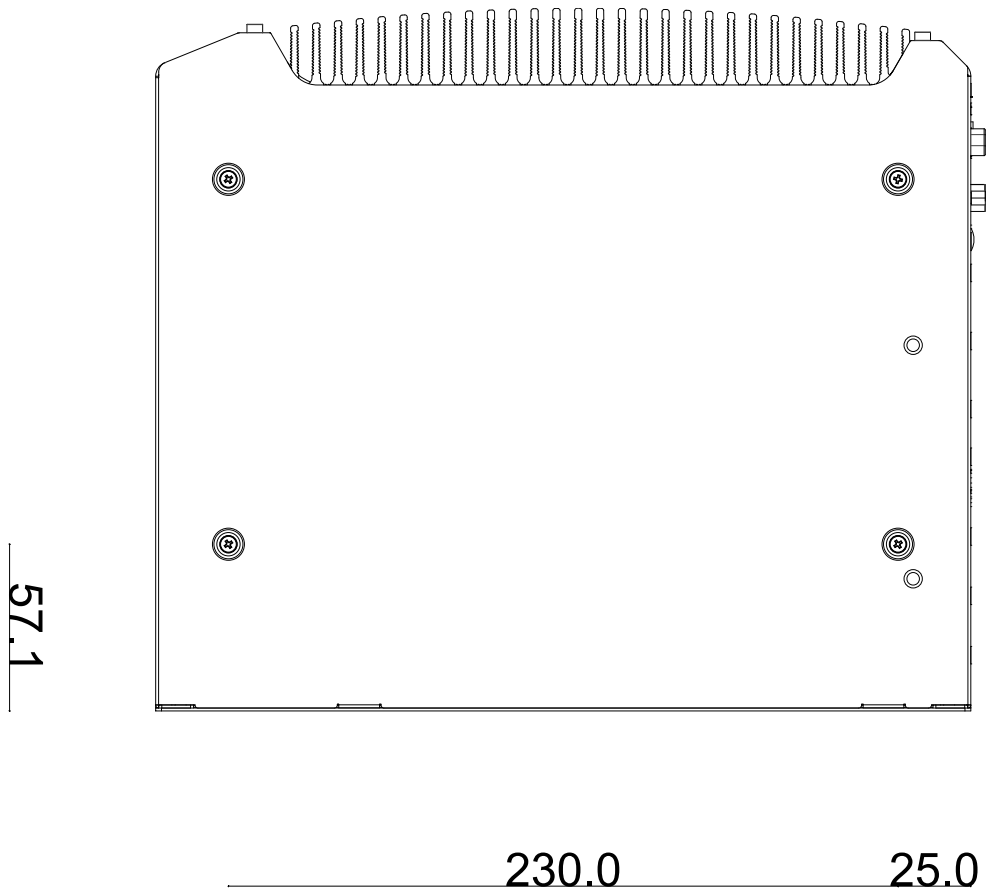

2 Overview

Upon receiving and unpacking your Nuvo-10000 system, please check immediately if the package contains all the items listed in the following table. If any item(s) are missing or damaged, please contact your local dealer or Neosys Technology.

2.1 Nuvo-10000 Packing List

System Pack	Nuvo-10000 series	Qty
1	Nuvo-10000 series system (If you ordered CPU/ RAM/ HDD, please verify these items)	1
2	Accessory box, which contains <ul style="list-style-type: none"> ● CPU bracket ● Wall-mount bracket ● 3-pin power terminal block ● Screw pack 	1 2 1 1

2.2 Nuvo-10000 Series I/O Panel

 **NOTE**

Nuvo-10000 series systems share the same I/O connections and differ only in their number of PCIe and PCI slots. For demonstration purposes, an illustration matching Nuvo-10007/10034 will be used in the following sections.

Nuvo-10000 series I/O Panel

The Nuvo-10000 I/O panel features HDMI, DisplayPort, USB3.2 Gen2/ Gen1, 2.5Gb Ethernet and COM ports.

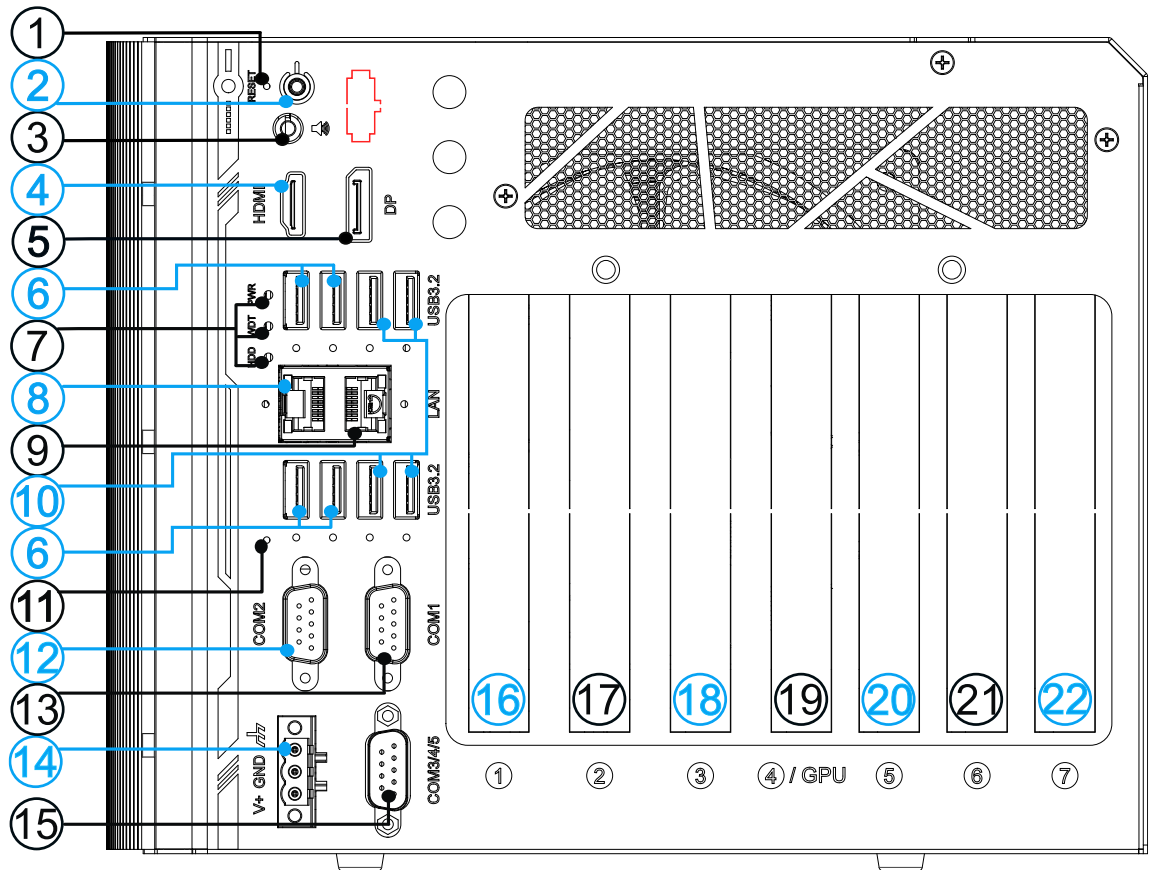

No.	Item	Description
1	Reset button	Use this button to manually reset the system.
2	Power Button	Use this button to turn on or shutdown the system.
3	3.5mm Speaker/Headphone Output Jack	The 4-pole 3.5mm jack accepts microphone voice input and headphone speaker sound output.
4	HDMI port	The HDMI port is a high-resolution graphics/ data port

		supporting up to 3840 x 2160 @ 30Hz.
5	DisplayPort	Support display resolutions up to 4096 x 2304. Compatible with HDMI/ DVI via respective adapter/ cable (resolution may vary).
6	USB3.2 Gen2x1 port	The ports offer up to 10 Gbps of data-throughput performance
7	LED indicator	From top to bottom, the LEDs are PWR (system power), WDT (watchdog timer), HDD (hard disk drive).
8	Gb Ethernet port	Gigabit Ethernet port by Intel® I219-LM
9	2.5Gb Ethernet port	2.5Gb Ethernet port by Intel® I226-IT
10	USB 3.1 Gen1 port	USB3.1 Gen 1 offers up to 5Gbps of data-throughput performance
11	Clear CMOS button	Use this button to clear the system CMOS.
12	COM 2 port	COM 2 port is a software-selectable RS-232/ 422/ 485 port. The operation mode can be set in BIOS.
13	COM 1 port	COM 1 port is a software-selectable RS-232/ 422/ 485 port. The operation mode can be set in BIOS.
14	3-pin terminal block	The system accepts 12-35V DC power input.
15	COM port 3/ 4/ 5	COM3, COM4 and COM5 are 3-wire RS-232 ports that share a single DB9 connector.
16	Expansion slot	PCIe x8 Gen3 4-lanes
17	Expansion slot	PCIe x8 Gen3 4-lanes (Nuvo-10007/ Nuvo-10034) PCIe x16 Gen3 16-lanes (Nuvo-10003)
18	Expansion slot	PCIe x16 Gen3 8-lanes (Nuvo-10007/ Nuvo-10034) PCIe x8 Gen3 4-lanes (Nuvo-10003)
19	Expansion slot	PCIe x16 Gen3 8-lanes (Nuvo-10007/ Nuvo-10034)
20	Expansion slot	PCIe x8 Gen3 4-lanes (Nuvo-10007) PCI 33MHz/ 32-bit 5V (Nuvo-10034)
21	Expansion slot	PCIe x4 Gen3 2-lanes (Nuvo-10007) PCI 33MHz/ 32-bit 5V (Nuvo-10034)
22	Expansion slot	PCIe x4 Gen3 2-lanes (Nuvo-10007) PCI 33MHz/ 32-bit 5V (Nuvo-10034)
		Reserved punch-out panel for On/ Off control and status LED extension. Please refer to its installation for details.

2.2.1 Reset Button

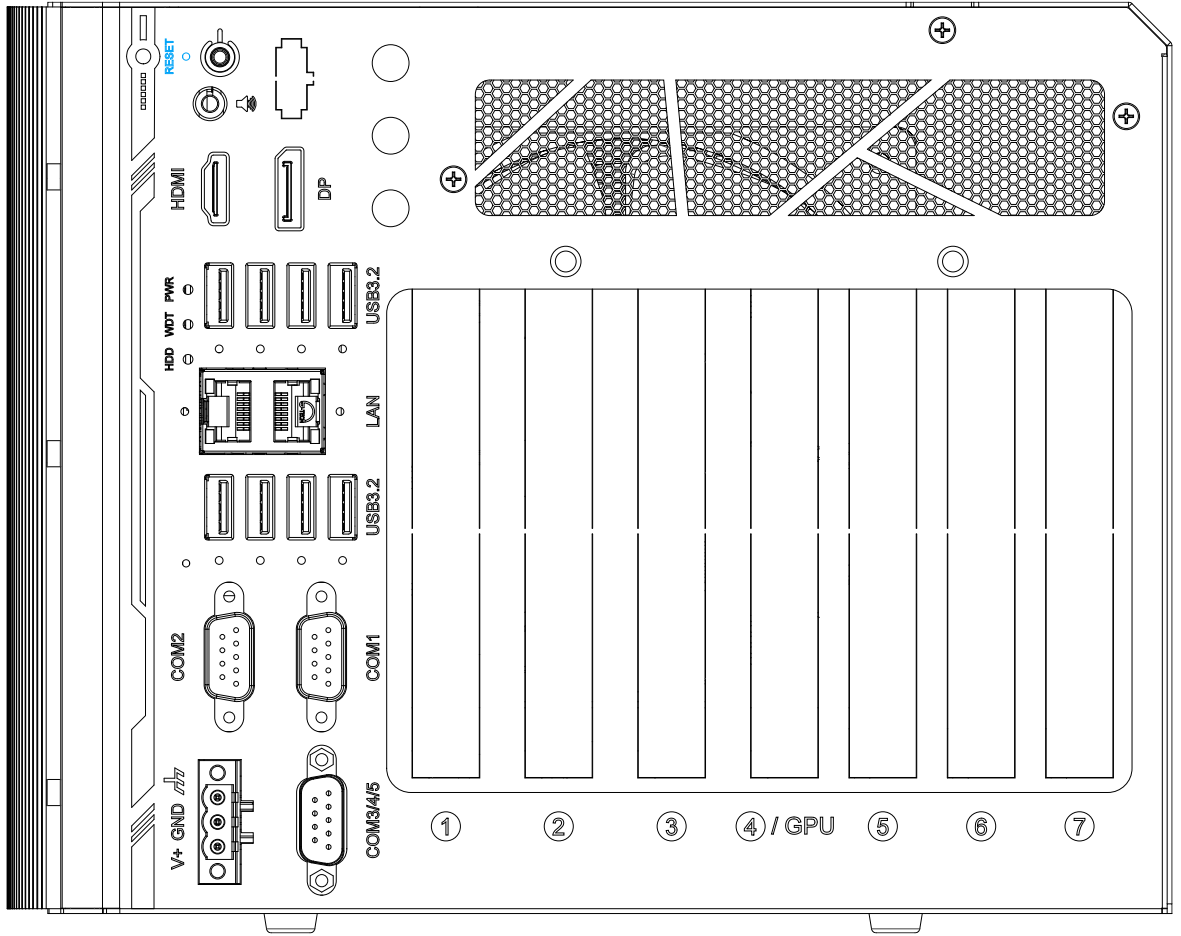

The reset button is used to manually reset the system in case of system halt or malfunction. To avoid unexpected reset, the button is purposely placed behind the panel. To reset, please use a pin-like object (eg. tip of a pen) to access the reset button.

2.2.2 Power Button

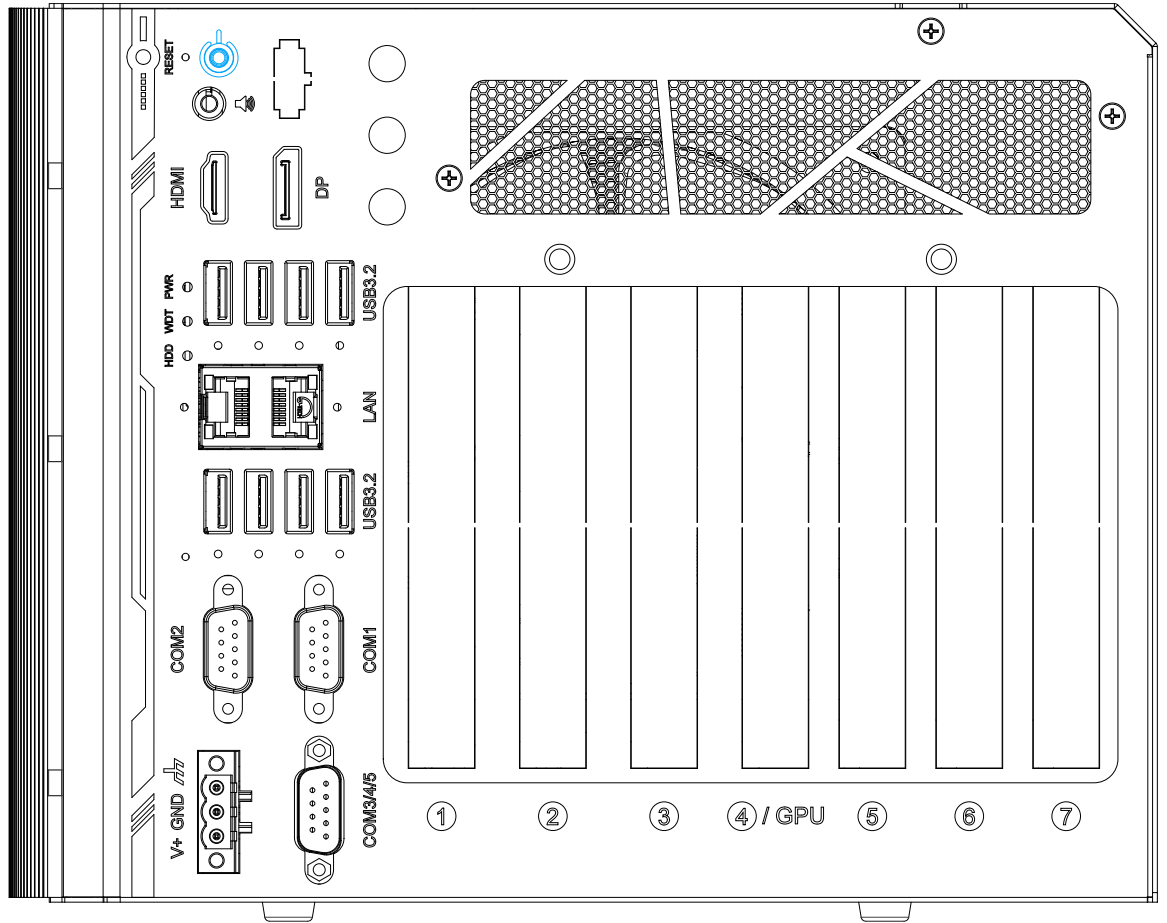

The power button is a non-latched switch for ATX mode on/off operation. To turn on the system, press the power button and the PWR LED should light-up green. To turn off the system, issuing a shutdown command in OS is preferred, or you can simply press the power button. To force shutdown when the system freezes, press and hold the power button for 5 seconds. Please note that there is a 5-second interval between on/off operations (i.e. once the system is turned off, there is a 5-second wait before you can power-on the system).

2.2.3 3.5mm Speaker/ Headphone Output Jack

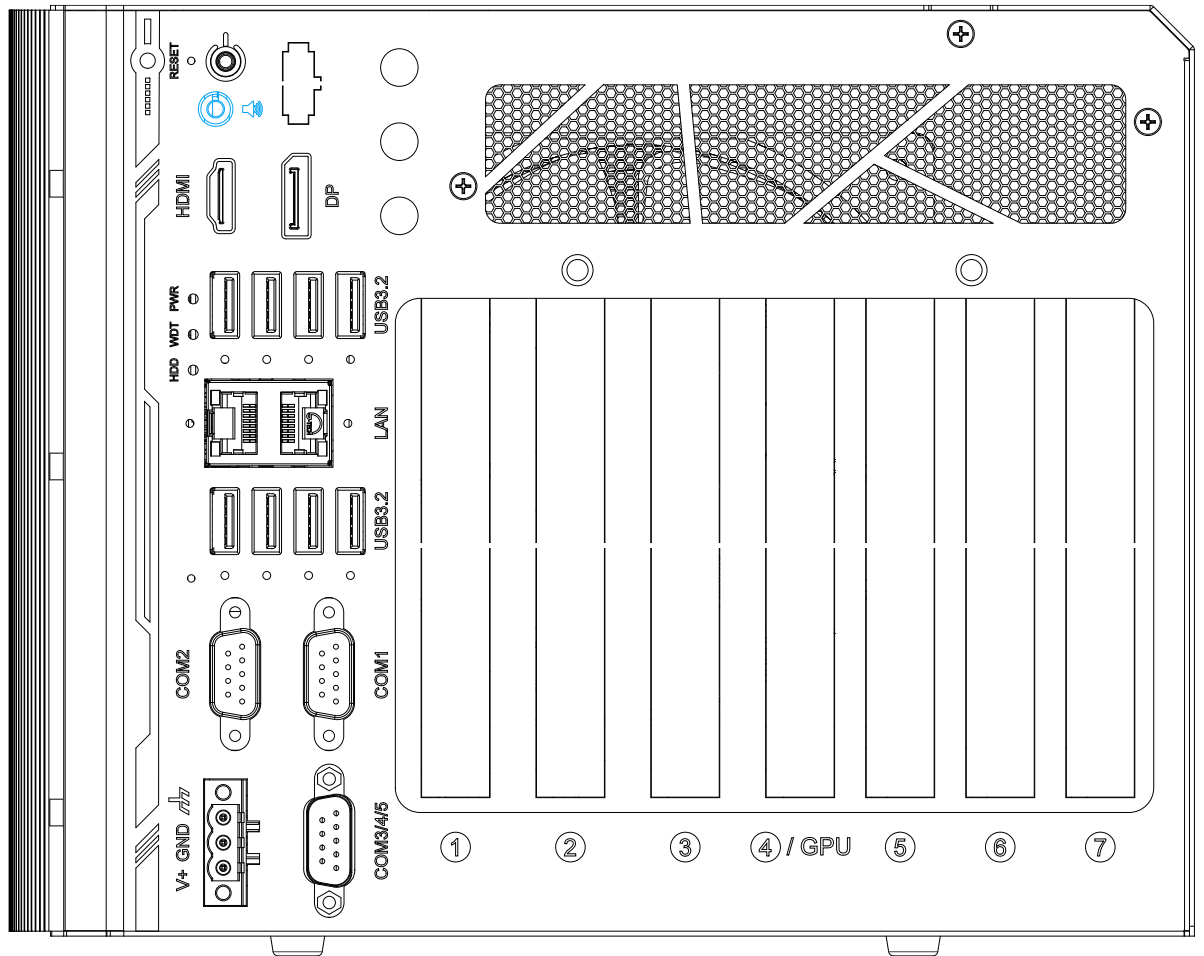

The system audio function uses high definition audio codec. There is a female 4-pole  audio jack for headphone (speaker) output and microphone input. To utilize the audio function in Windows, you need to install corresponding drivers for both Intel® Q670 chipset and audio device drivers.

2.2.4 HDMI Port

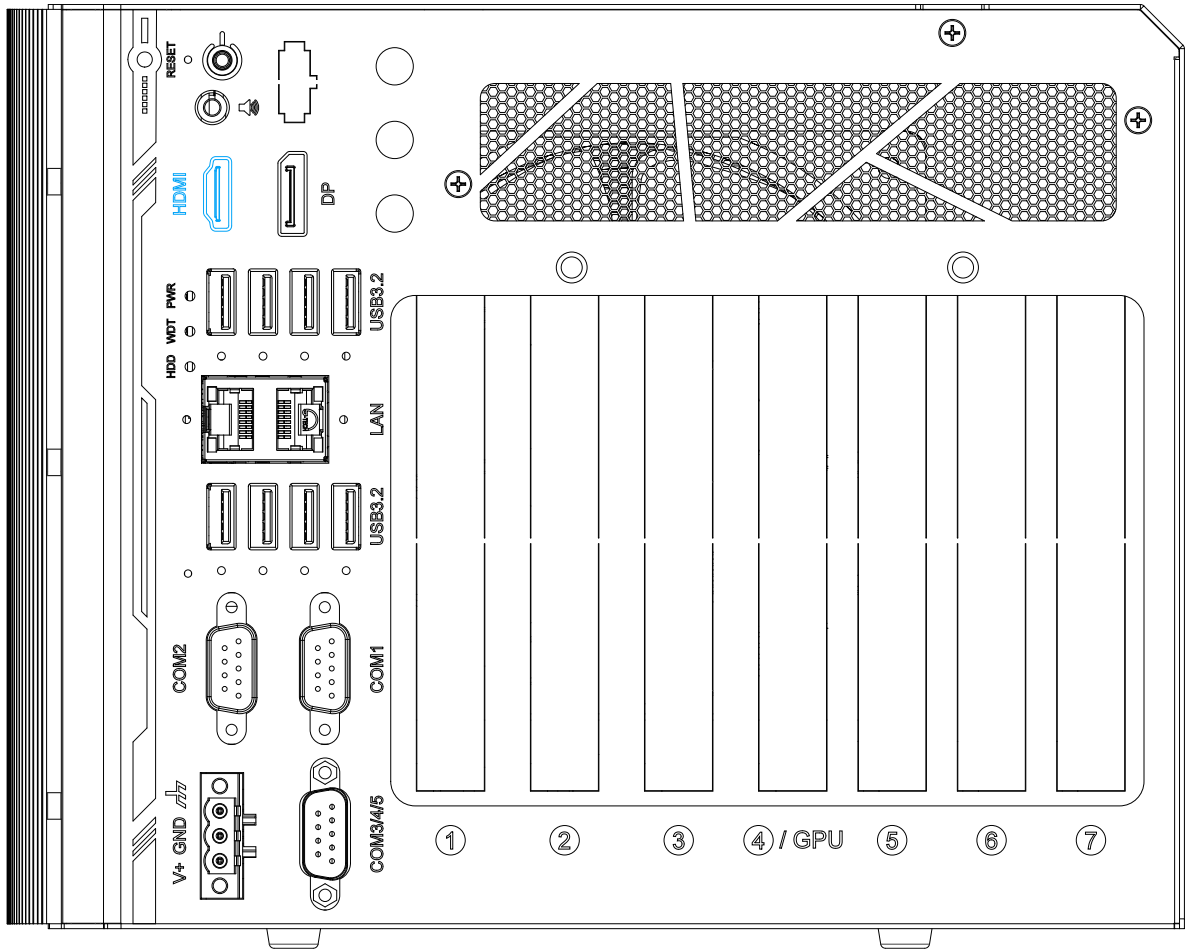

The High-Definition Multimedia Interface (HDMI) port provides uncompressed high-quality digital video and audio transmission between the system and a multimedia display device on a single cable. You can connect to other digital inputs by using a HDMI-to-DVI or HDMI-to-DP cable.

The system supports dual independent display outputs by connecting display devices to HDMI and DisplayPort connection. To support dual display outputs and achieve best DisplayPort output resolution in Windows, you need to install corresponding graphics drivers. Please refer to section [OS Support and Driver Installation](#) for details.



HDMI-to-DP

2.2.5 DisplayPort

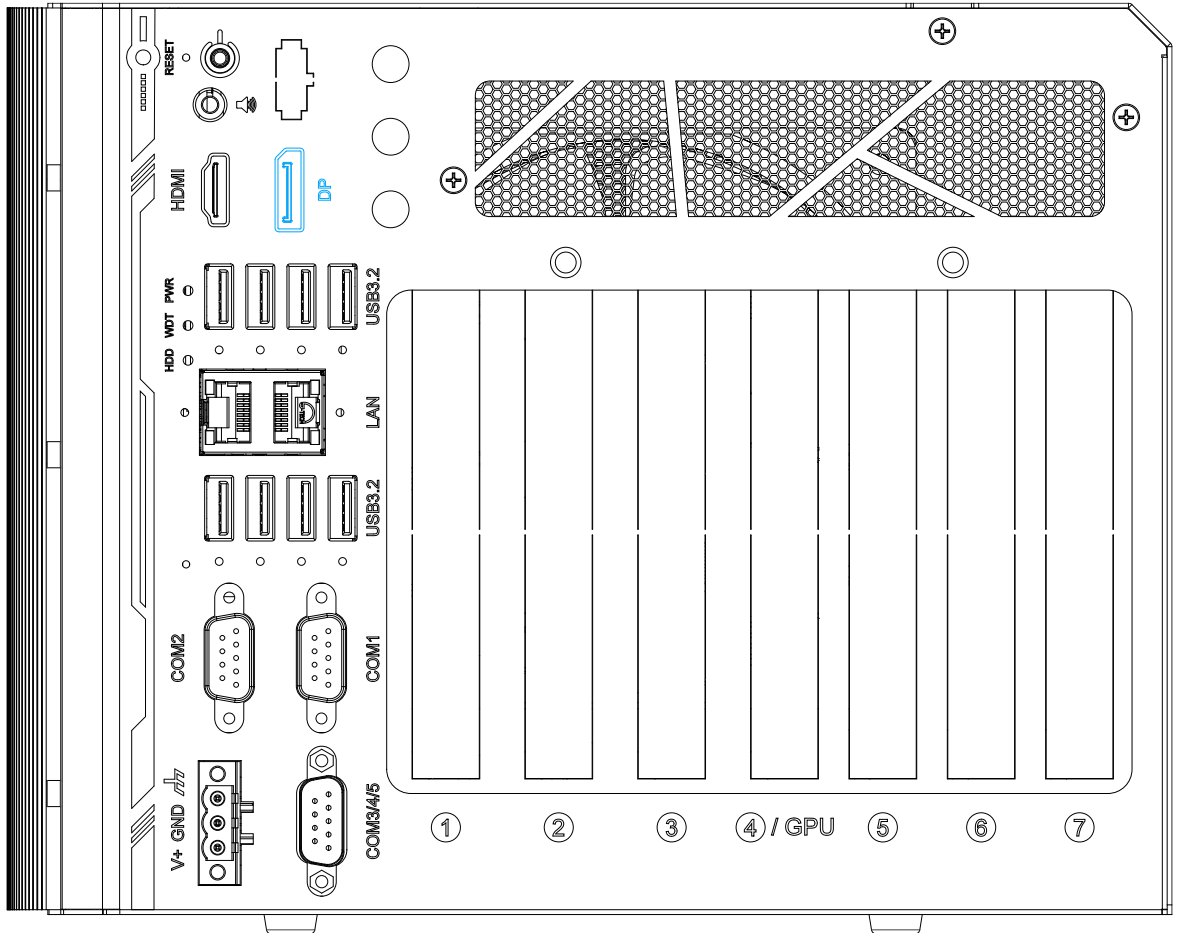

The DisplayPort (DP) output is a digital display interface that mainly connect video source and carry audio to a display device. When connecting a DP, it can deliver up to 4K UHD (4096 x 2304) in resolution. The system is designed to support passive DP adapter/ cable. You can connect to other display devices using DP-to-HDMI cable or DP-to-DVI cable.



DP-to-HDMI



DP-to-DVI

The system supports triple independent display outputs by connecting display devices to VGA, DVI and DisplayPort connection. To support multiple display outputs and achieve best DisplayPort output resolution in Windows, you need to install corresponding graphics drivers. Please refer to section [OS Support and Driver Installation](#) for details.

2.2.6 USB3.2 Gen2x1

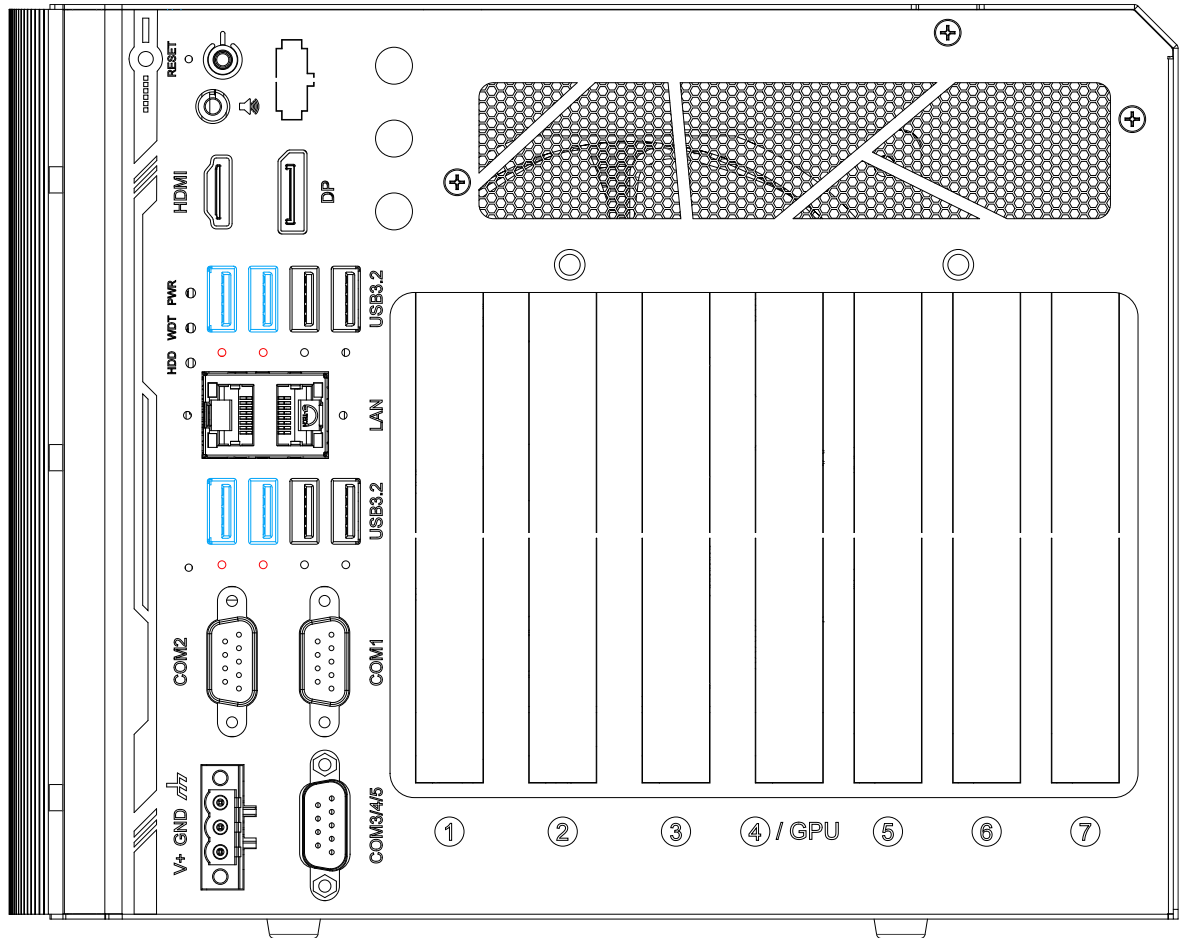

The system's USB 3.2 Gen2x1 ports (10Gbps) feature panel screw fix hole (indicated in **red**), and are implemented via native xHCI (eXtensible Host Controller Interface) controller. They are backward compatible with USB3.2 Gen.1 USB 2.0, USB 1.1 and USB 1.0 devices. Legacy USB is also supported so you can use USB keyboard/mouse in DOS environment.

xHCI driver is supported natively in Windows 10, therefore you do not need to install xHCI driver in prior to utilize USB functions.

2.2.7 LED Indicators

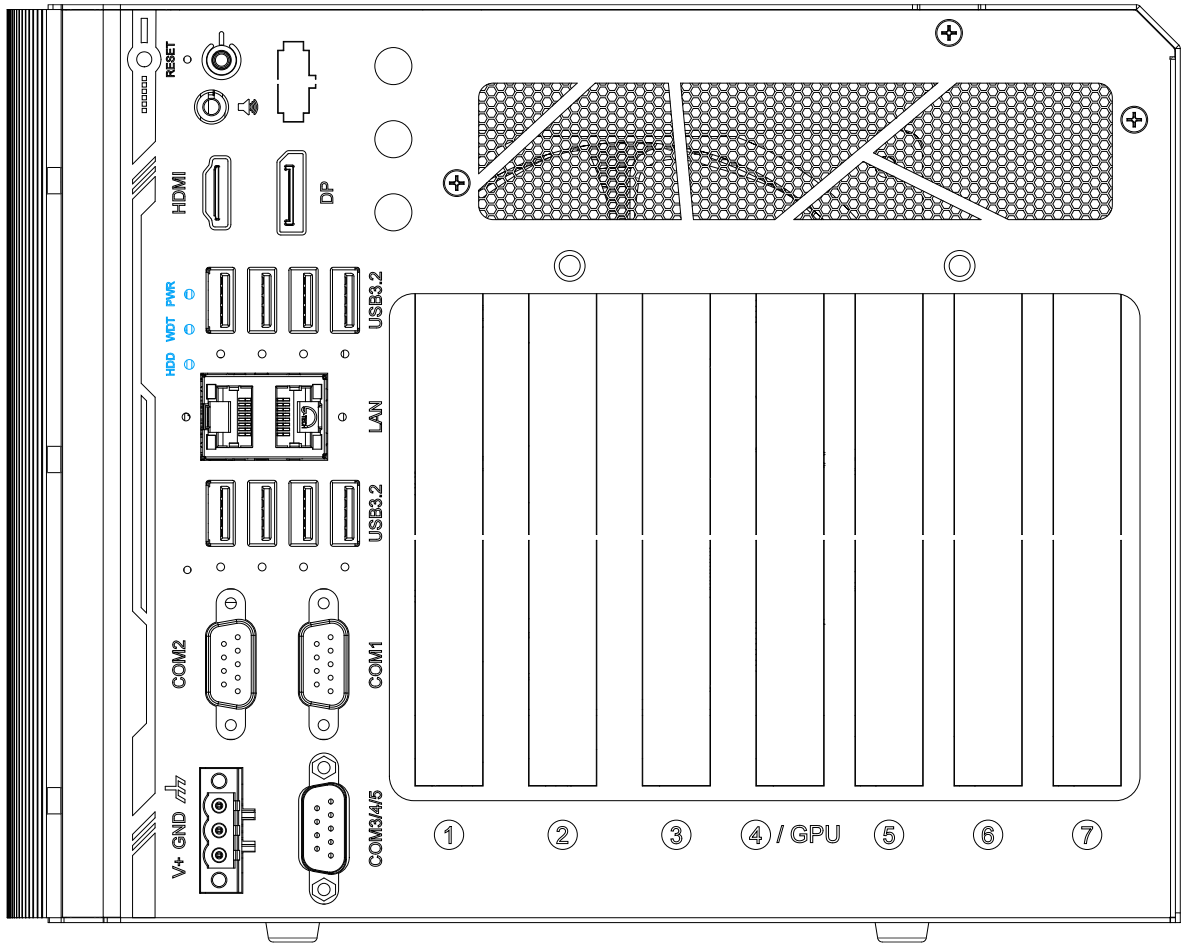

There are three LED indicators on the I/O panel. From top to bottom, they are power (PWR), Watchdog timer (WDT) and hard disk drive activity (HDD). The descriptions of these three LEDs are listed in the following table.

Indicator	Color	Description
PWR	Green	Power indicator, lid when system is on.
WDT	Yellow	Watchdog timer LED, flashing when WDT is active.
HDD	Red	Hard drive indicator, flashing when hard disk drive is active.

2.2.8 Gigabit Ethernet Port

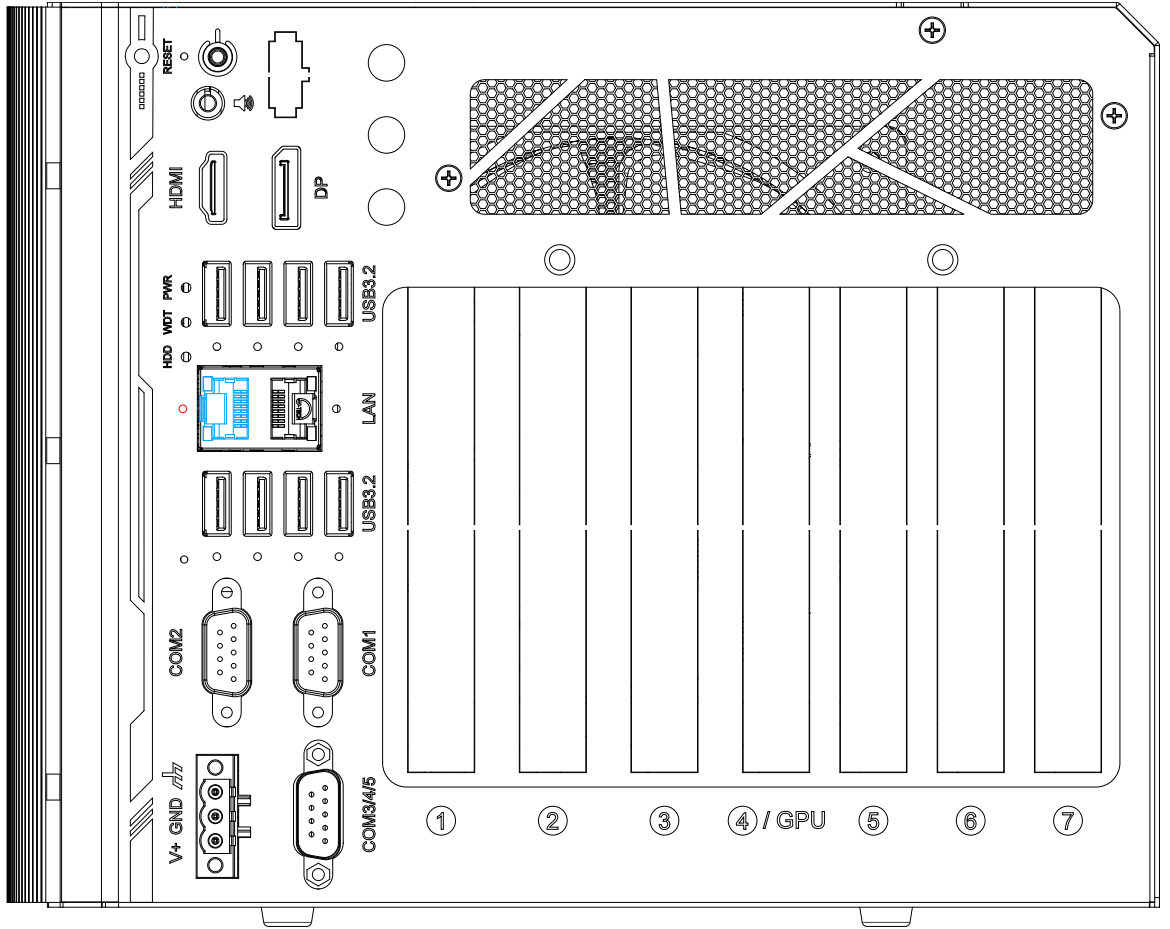

The system has a GbE port featuring panel screw fix hole (indicated in **red**), and it supports Wake-on-LAN functions. The GbE port is implemented with Intel® I219-LM controller with one dedicated PCI Express link for maximum performance. When the Ethernet connection is established, the LED indicators on the RJ45 connector represents the following connection statuses:

Active/Link LED

LED Color	Status	Description
Green	Off	Ethernet port is disconnected
	On	Ethernet port is connected and no data transmission
	Flashing	Ethernet port is connected and data is transmitting/receiving

Speed LED

LED Color	Status	Description
Green or Orange	Off	10 Mbps
	Green	100 Mbps
	Orange	1000 Mbps

Drivers must be installed to utilize the GbE port in Windows environment.

2.2.9 2.5G Ethernet Port

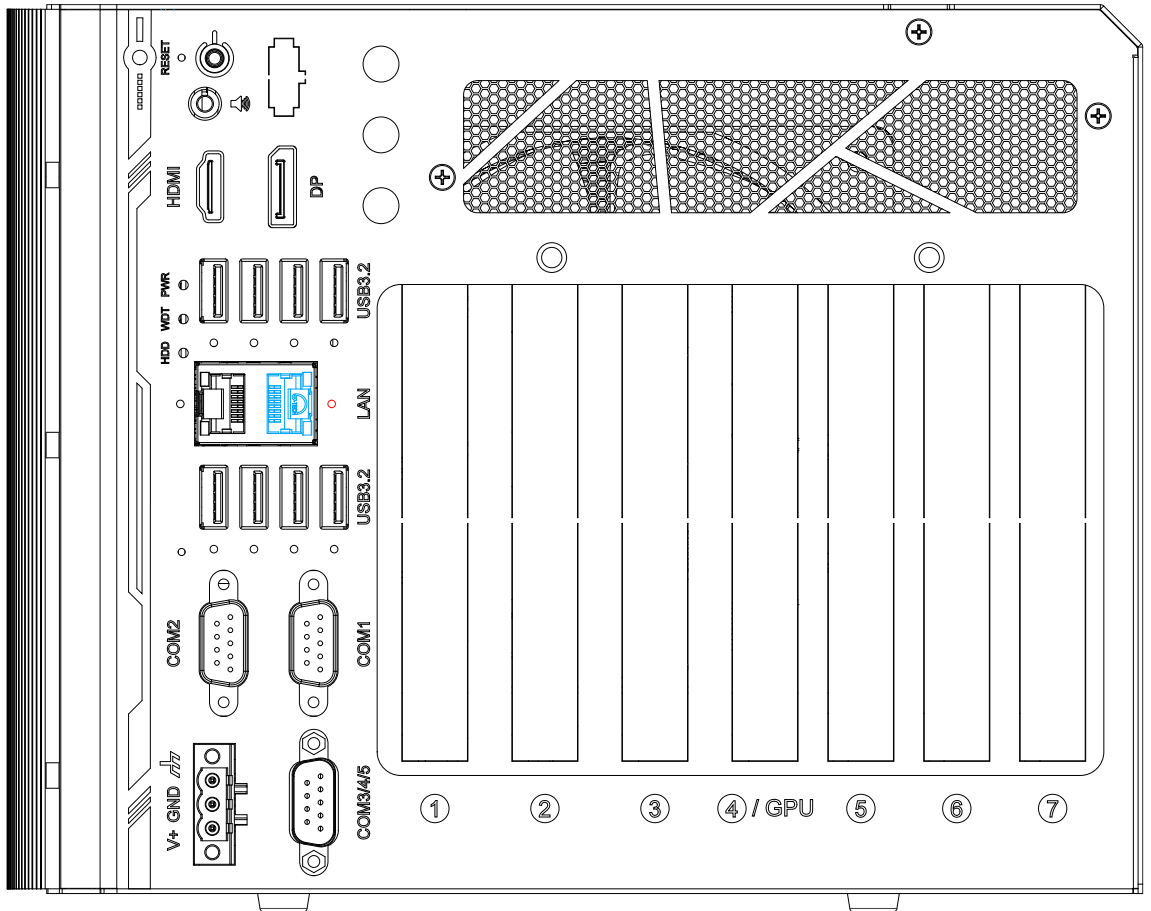

The system has a 2.5Gb Ethernet port featuring panel screw fix hole (indicated in **red**).

The port has one dedicated PCI Express link for maximum network performance. Please refer to the table below for LED connection statuses.

Active/Link LED

LED Color	Status	Description
Orange	Off	Ethernet port is disconnected
	On	Ethernet port is connected and no data transmission
	Flashing	Ethernet port is connected and data is transmitting/receiving

Speed LED

LED Color	Status	Description
Red or Green	Off	10 Mbps
	Green	100 Mbps
	Red	1000/ 2500 Mbps

To utilize the Ethernet port in Windows, you need to install corresponding driver for the Ethernet controller.

2.2.10 USB3.2 Gen1x1 Port

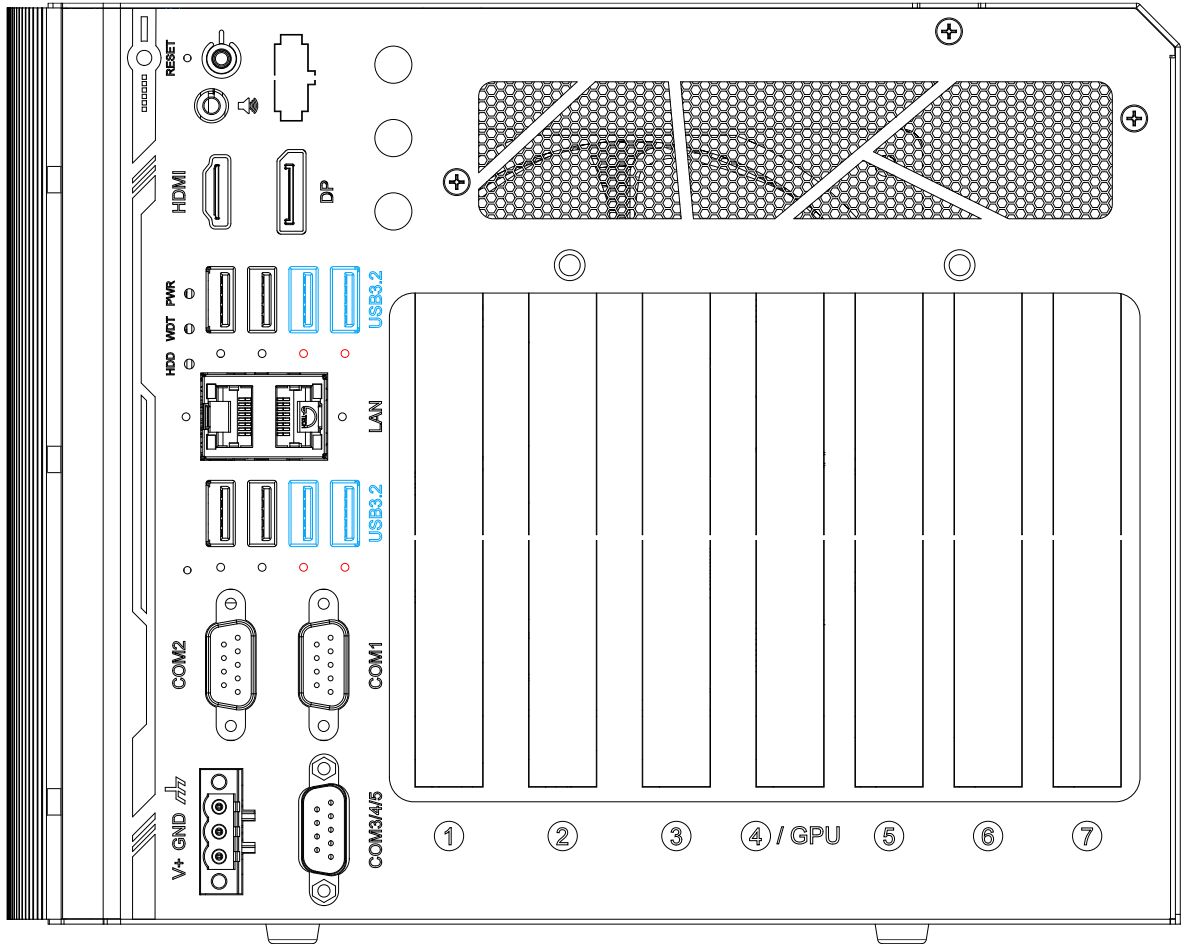

The system's USB 3.2 Gen1x1 ports (5Gbps) feature panel screw fix hole (indicated in **red**), and are implemented via native xHCI (eXtensible Host Controller Interface) controller. They are backward compatible with USB 2.0, USB 1.1 and USB 1.0 devices.

Legacy USB is also supported so you can use USB keyboard/mouse in DOS environment. xHCI driver is supported natively in Windows 10, therefore you do not need to install xHCI driver in prior to utilize USB functions.

2.2.11 Clear CMOS Button

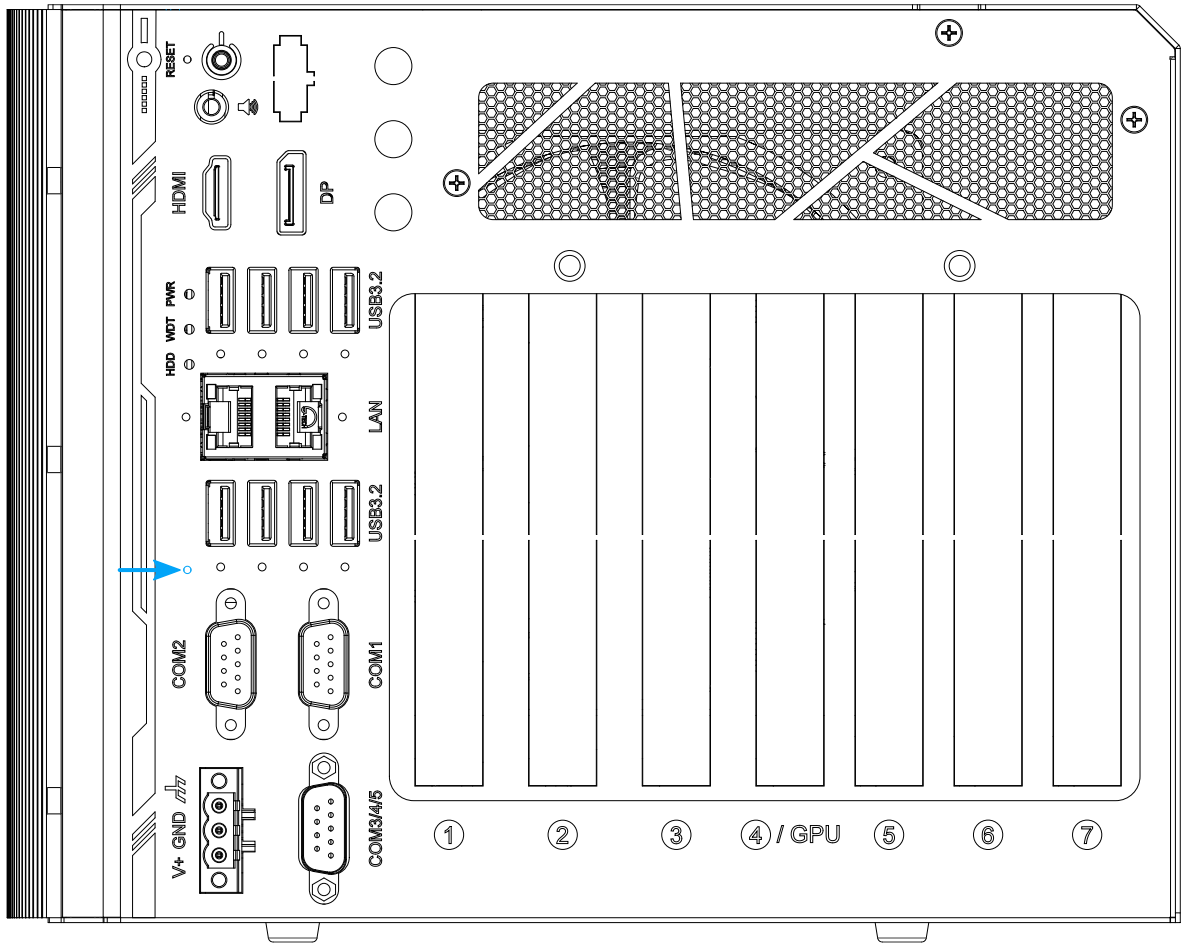

Indicated by the **blue arrow**, the CMOS Reset button is used to manually reset the motherboard BIOS in case of system halt or malfunction. To avoid unexpected operation, it is purposely placed behind the panel. To reset, please use the tip of a pen, press and hold for at least 5 seconds to reset the BIOS.

2.2.12 COM2 Port

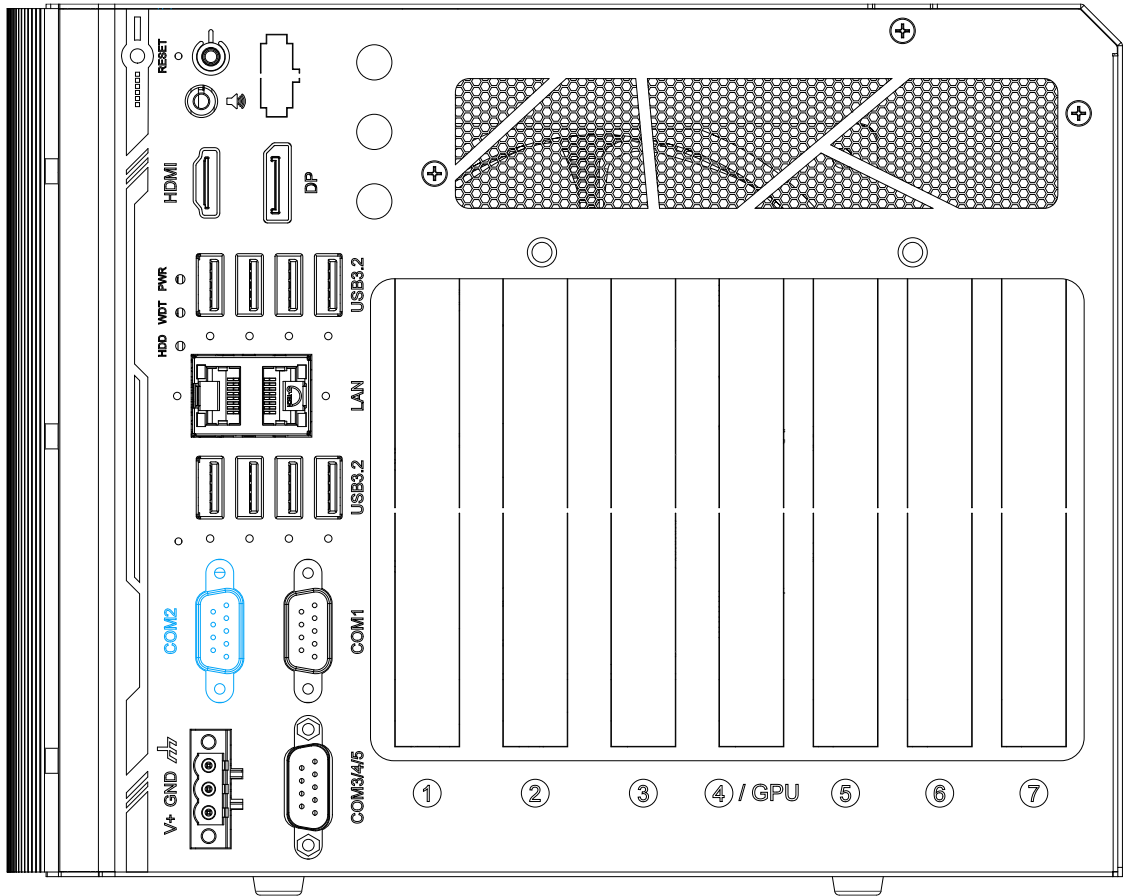

The COM port is implemented using industrial-grade ITE8786 Super IO chip (-40 to 85°C) and provide up to 115200 bps baud rate. It is a software-configurable RS-232/422/485 port. The operation mode of can be set in BIOS setup utility. The following table describes the pin definition of the COM port.

COM Port Pin Definition

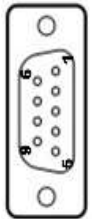

Pin#	COM1		
	RS-232 Mode	RS-422 Mode	RS-485 Mode (Two-wire 485)
1	DCD		
2	RX	422 TXD+	485 TXD+/RXD+
3	TX	422 RXD+	
4	DTR	422 RXD-	
5	GND	GND	GND
6	DSR		
7	RTS		
8	CTS	422 TXD-	485 TXD-/RXD-
9	RI		

2.2.13 COM1 Port

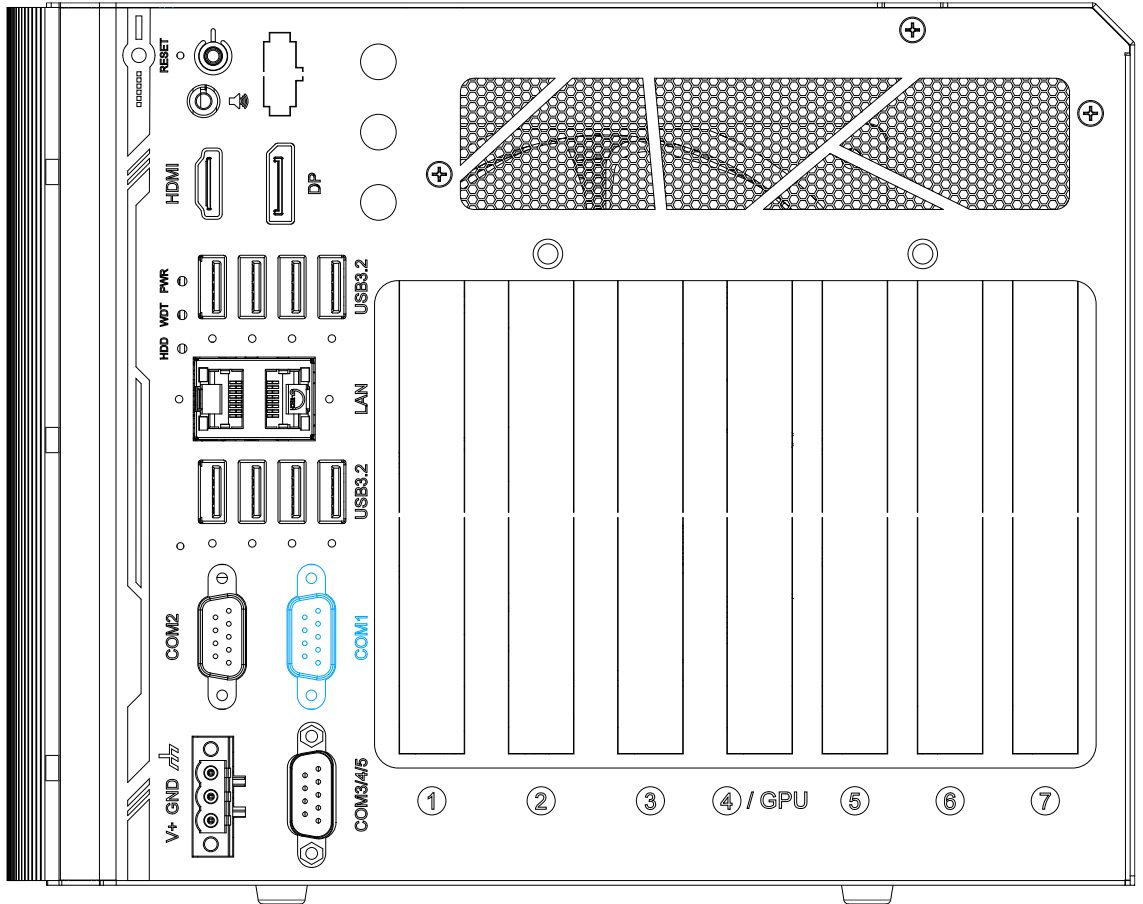

The COM1 port is implemented using industrial-grade ITE8786 Super IO chip (-40 to 85°C) and provide up to 115200 bps baud rate. It is a software-configurable RS-232/422/485 port. The operation mode of can be set in BIOS setup utility. The following table describes the pin definition of the COM port.

COM Port Pin Definition

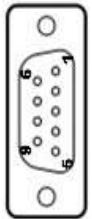

Pin#	COM1		
	RS-232 Mode	RS-422 Mode	RS-485 Mode (Two-wire 485)
1	DCD		
2	RX	422 TXD+	485 TXD+/RXD+
3	TX	422 RXD+	
4	DTR	422 RXD-	
5	GND	GND	GND
6	DSR		
7	RTS		
8	CTS	422 TXD-	485 TXD-/RXD-
9	RI		

2.2.14 3-pin Terminal Block for DC Input

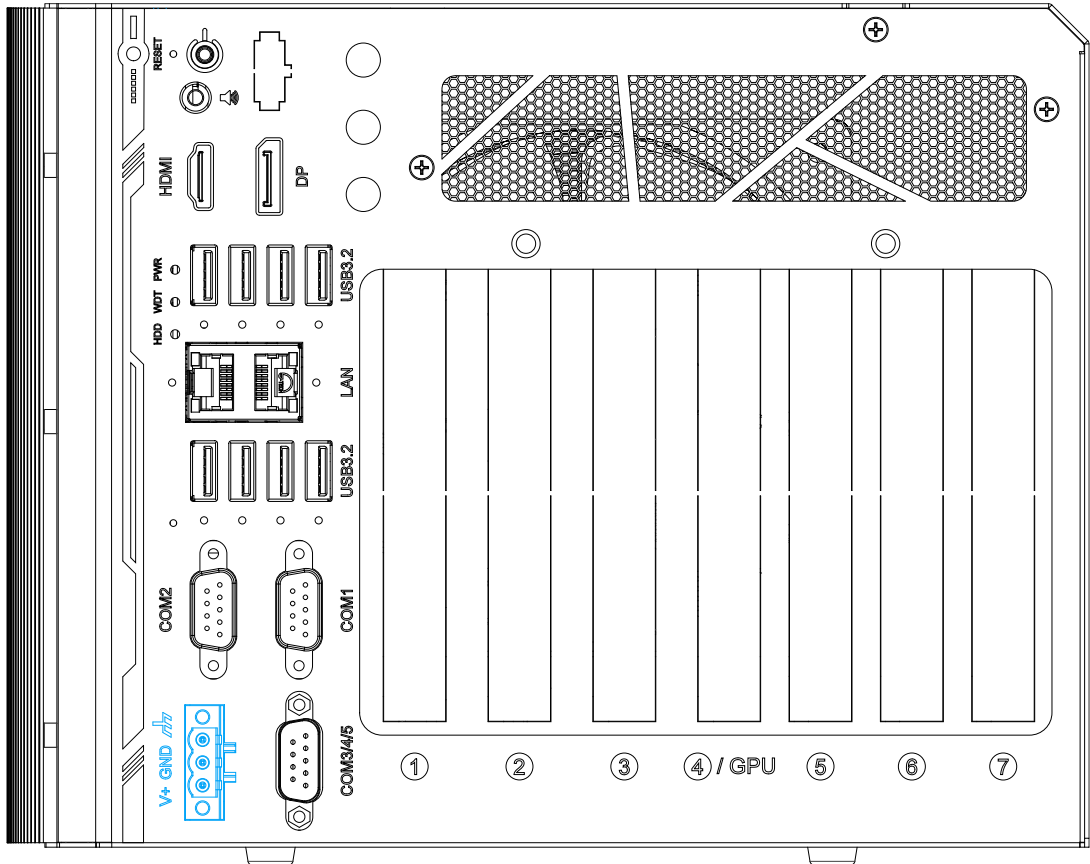

The system accepts a wide range of DC power input from 12 to 35V via 3-pin pluggable terminal block, which is fit for field usage where DC power is provided. And the screw clamping connection of the terminal block gives a very reliable way of wiring DC power.

Symbol	Description
	Chassis ground (connected to the earth ground)
GND	Negative polarity (ground) of DC input
V+	Positive polarity of DC input

 **WARNING**

Please make sure the voltage of DC power is correct before you connect it to the system. Supplying a voltage over 35V will damage the system.

 **NOTE**

When system load is 150W or less, the required DC input range is 12V to 35V; when the system load is between 151W and 320W (with a GPU card), the required DC input is 24V to 35V.

2.2.15 COM3/ 4/ 5 Port

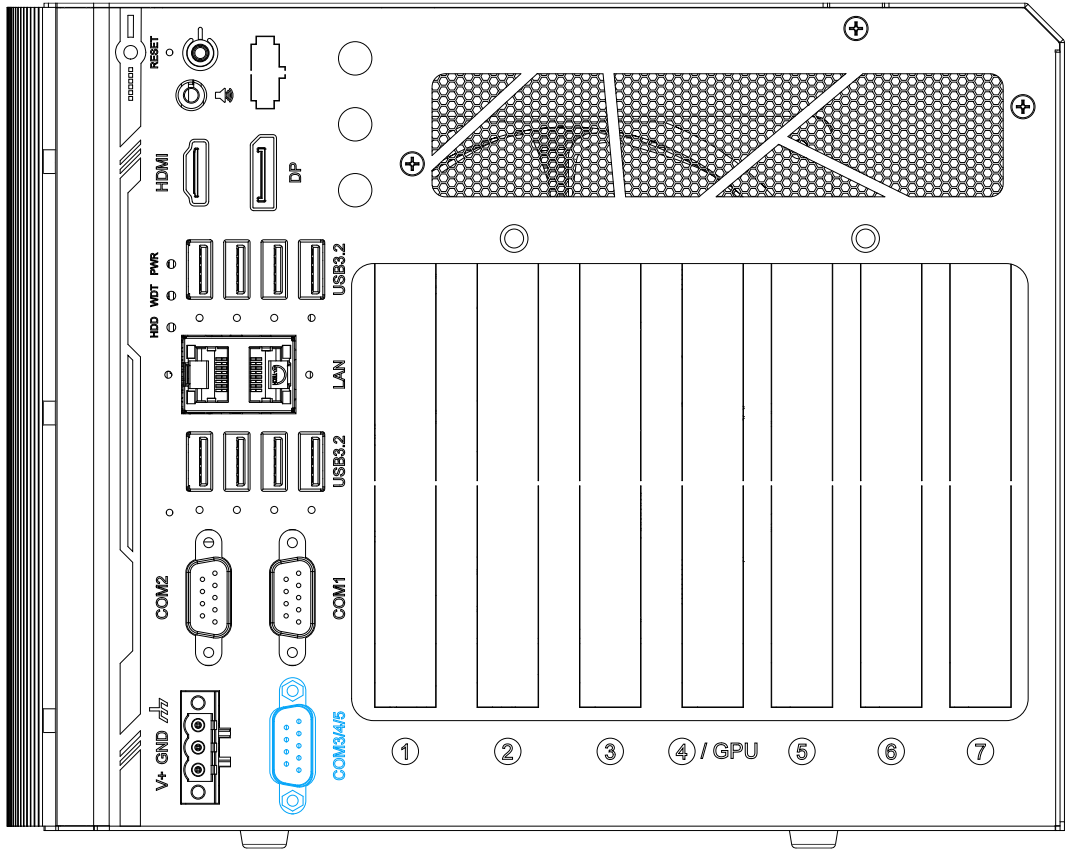

COM3, COM4 and COM5 are 3-wire RS-232 ports share single DB9 connector. You can directly connect this to one external device with 3-wire RS-232 interface, or use an optional 1-to-3 Y-cable to have three DB9 connectors for more devices. The following table describes the pin definition of the DB9 connector as well as the Y-cable.

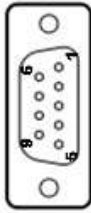

Pin#	COM3/ 4/ 5 DB9		
	COM3	COM4	COM5
1			
2	RX		
3	TX		
4		TX	
5	GND	GND	GND
6		RX	
7			TX
8			RX
9			

Pin#	Y-Cable DB9
1	
2	RX
3	TX
4	
5	GND
6	
7	
8	
9	

2.3 Internal I/O Functions

In addition to I/O connectors on the front panel, the system also provides internal on-board connectors, such as remote on/off control, LED status output, internal USB 2.0 ports, etc. In this section, we'll illustrate these internal I/O functions.

2.3.1 SODIMM DRAM Slot

The system motherboard supports two DDR5 4800MHz SODIMM modules up to 64GB capacity. The slots are situated on both the expansion slot and CPU socket sides of the motherboard.



Expansion slot side

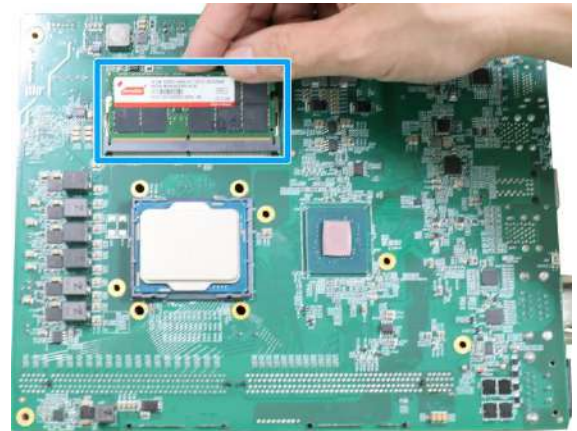

CPU socket side



NOTE

When changes are made to DRAM module(s), such as additionally install or remove and re-install (into the same/ different slot, it will result in an approximately 30~60 seconds delay when booting up for the first time after such change(s).

2.3.2 mini-PCIe Slot & Pin Definition

The system provides two mini-PCIe sockets (indicated in blue) that is in compliance with mini-PCIe specification rev. 1.2. The mini-PCIe sockets are designed with a SIM card (slot indicated in red) support. With a SIM card installed, your system can access the internet via your network provider's 4G/ 3G network.

For wireless (WiFi/ 4G/ 3G) communication, multiple SMA antenna apertures can be located on the IO panel.

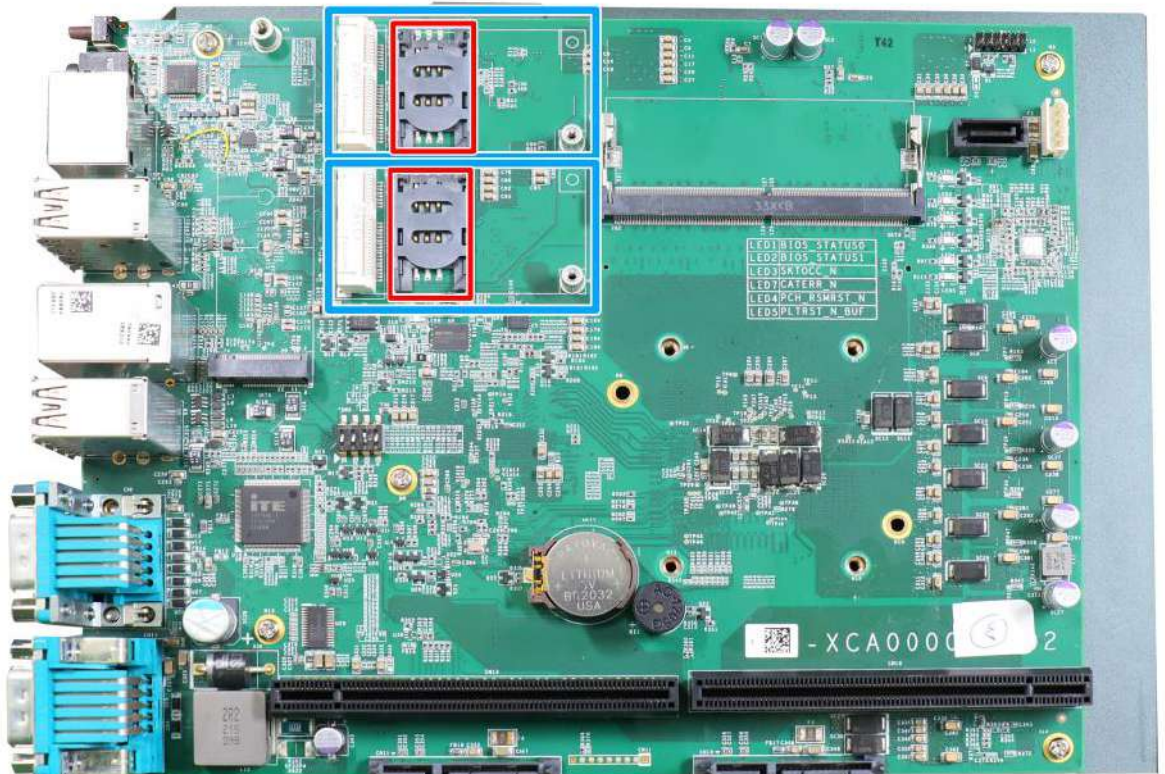

For wireless (WiFi/ 3G/ 4G) communication, SMA antenna apertures can be located on the front panel.

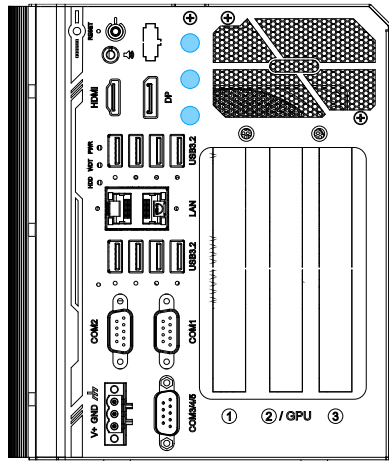

Nuvo-10003

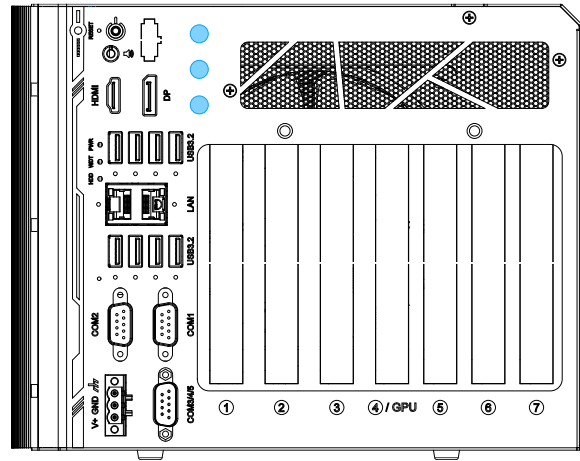

Nuvo-10007/ 10043

mini-PCIe socket definition

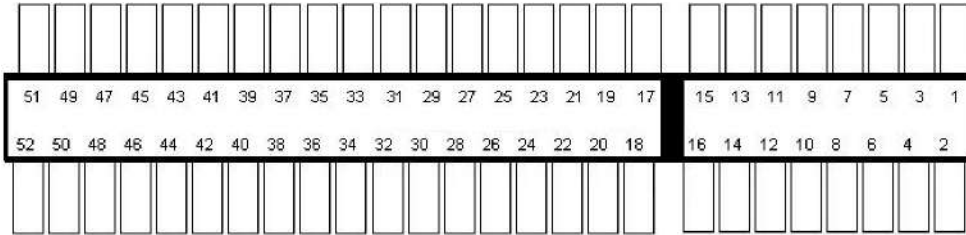

Pin #	Signal (mPCIe)	Pin #	Signal (mPCIe)
1	WAKE#	2	+3.3Vaux
3	-	4	GND
5	-	6	+1.5V
7	CLKREQ#	8	UIM_PWR
9	GND	10	UIM_DATA
11	REFCLK-	12	UIM_CLK
13	REFCLK+	14	UIM_RESET
15	GND	16	UIM_VPP
Mechanical Key			
17	Reserved* (UIM_C8)	18	GND
19	Reserved* (UIM_C4)	20	W_DISABLE#
21	GND	22	PERST#
23	PERn0	24	3.3V
25	PERp0	26	GND
27	GND	28	+1.5V
29	GND	30	SMB_CLK
31	PETn0	32	SMB_DATA
33	PETp0	34	GND
35	GND	36	USB_D-
37	GND	38	USB_D+
39	3.3V	40	GND
41	3.3V	42	-
43	GND	44	-
45	Reserved	46	-
47	Reserved	48	+1.5V
49	Reserved	50	GND
51	Reserved	52	3.3V

 **WARNING**

Some off-the-shelf mini-PCIe 4G modules are not compliant to standard mini-PCIe interface. They use 1.8V I/O signals instead of standard 3.3V I/O and may have signal conflict. Please consult with Neosys for compatibility when in doubt!

Installing an incompatible 4G module may damage the system or the module itself may be damaged.

2.3.3 M.2 2280 M Key Slot (SATA Signal Only)



The system has an M.2 2280 slot (SATA signal only) for you to install an M.2 SATA SSD for faster access over traditional hard disk drives.



NOTE

The M.2 slot is only compatible with SATA signal M.2 SSD only.

M.2 2280 M Key Pin Definition

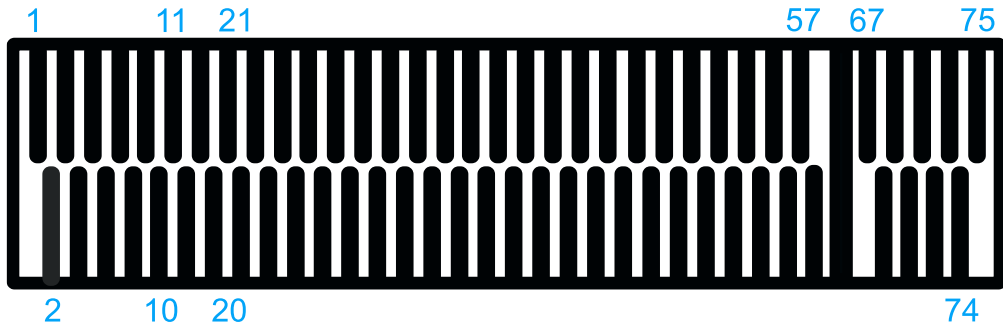

Pin #	Signal	Pin #	Signal
1	GND	2	+3V3
3	GND	4	+3V3
5		6	-
7		8	-
9	GND	10	DAS/DSS_N
11		12	+3V3
13		14	+3V3
15	GND	16	+3V3
17		18	+3V3
19		20	-
21	GND	22	-
23		24	-
25		26	-
27	GND	28	-
29		30	-
31		32	-
33	GND	34	-
35		36	DEVSLP
37		38	-
39	GND	40	-
41	SATA-B+	42	-
43	SATA-B-	44	-
45	GND	46	-
47	SATA-A-	48	-
49	SATA-A+	50	PERST N
51	GND	52	-
53		54	-
55		56	-
57	GND	58	-
Mechanical Key			
67	-	68	SUSCLK
69	PEDET	70	+3V3
71	GND	72	+3V3
73	GND	74	+3V3
75	GND		

2.3.4 SATA Ports



NOTE

Supports up to 15mm thickness HDD/ SSD.

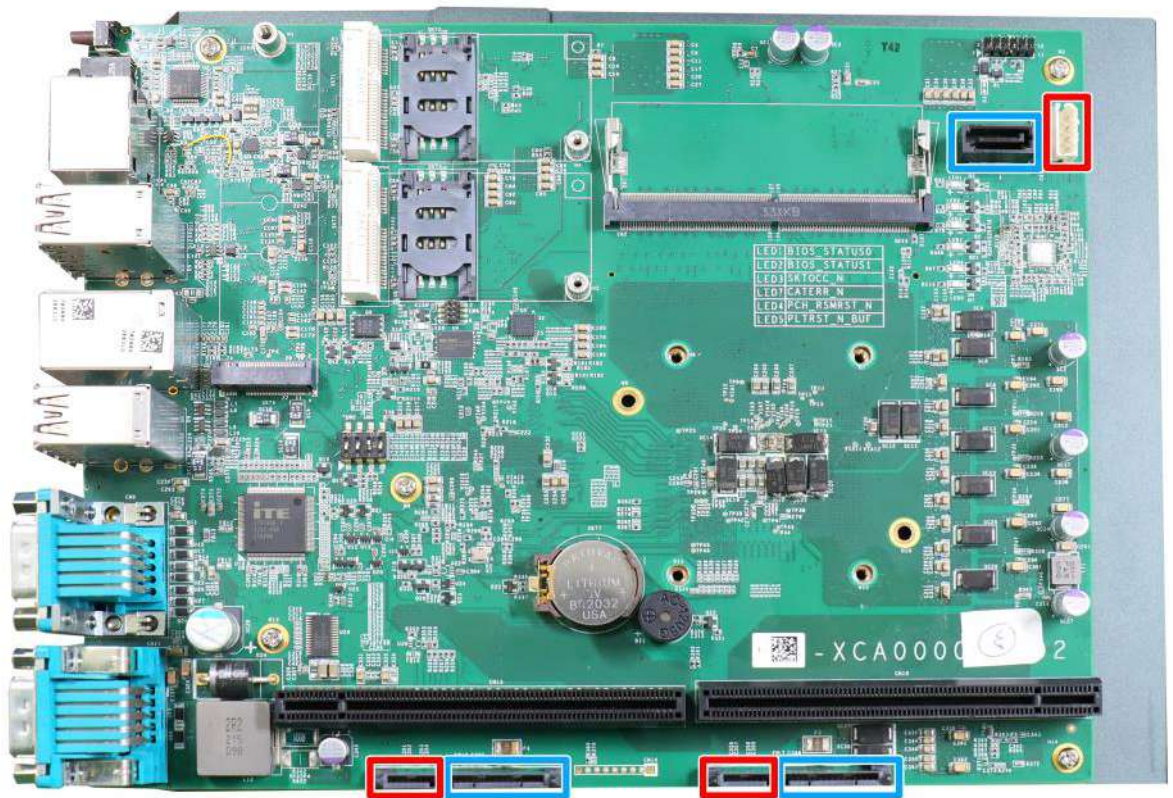

The system provides three SATA ports which support Gen3, 6 Gb/s SATA signals. The SATA ports are indicated in **blue**, and each of their power connectors (indicated in **red**) are situated along side.

2.3.5 On/ Off Ctrl & Status Output

For an application which places Nuvo-10000 inside a cabinet, it's useful to output the system status to external LED indicators so that users can check how the system's running. Nuvo-10000 provides a 2x6, 2.0mm pitch pin header to output system status such as power, HDD, watchdog timer, and control system on/off remotely. The status LED output has a built-in series-resistor and provides 10mA current to directly drive the external LED indicators. System on/off control is also provided so you can use an external non-latched switch to turn on/off the system exactly the same as the power button on the front panel.



An optional cable is available to connect the output pins to the I/O panel of the system. If you purchased the optional cable and wish to install it, please refer to this section.

On/Off Status Control Pin Definition

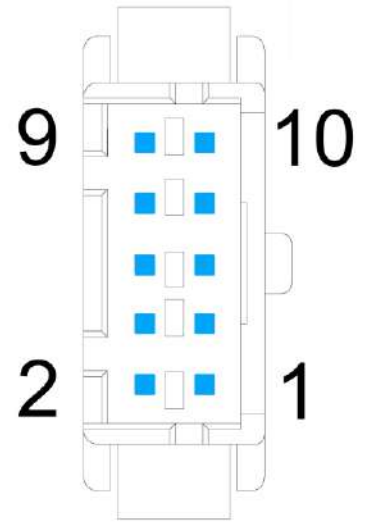
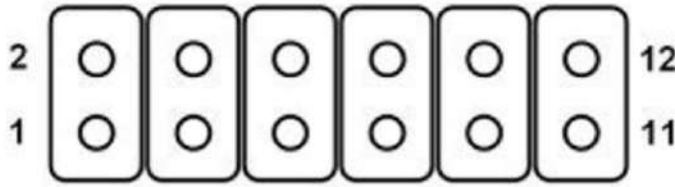

Motherboard pins

I/O panel pins

Pin#	Definition	Description
1	WDT_LED-	[Output] Watchdog timer indicator, flashing when Watchdog timer is active
2	WDT_LED+	
3	UID_LED-	[Output] User defined LED, reserved for future usage
4	UID_LED+	
5	HDD-	[Output] Hard drive indicator, flashing when SATA hard drive is active.
6	HDD+	
7	Power_LED-	[Output] System power indicator, on if system is turned on, off if system is turned off.
8	Power_LED+	
9	Ctrl-	[Input] Remote on/off control, connects to an external switch to turn on/off the system (polarity is negligible).
10	Ctrl+	
11	NA	Un-used pin
12	NA	

2.3.6 4-Pin Power Connector

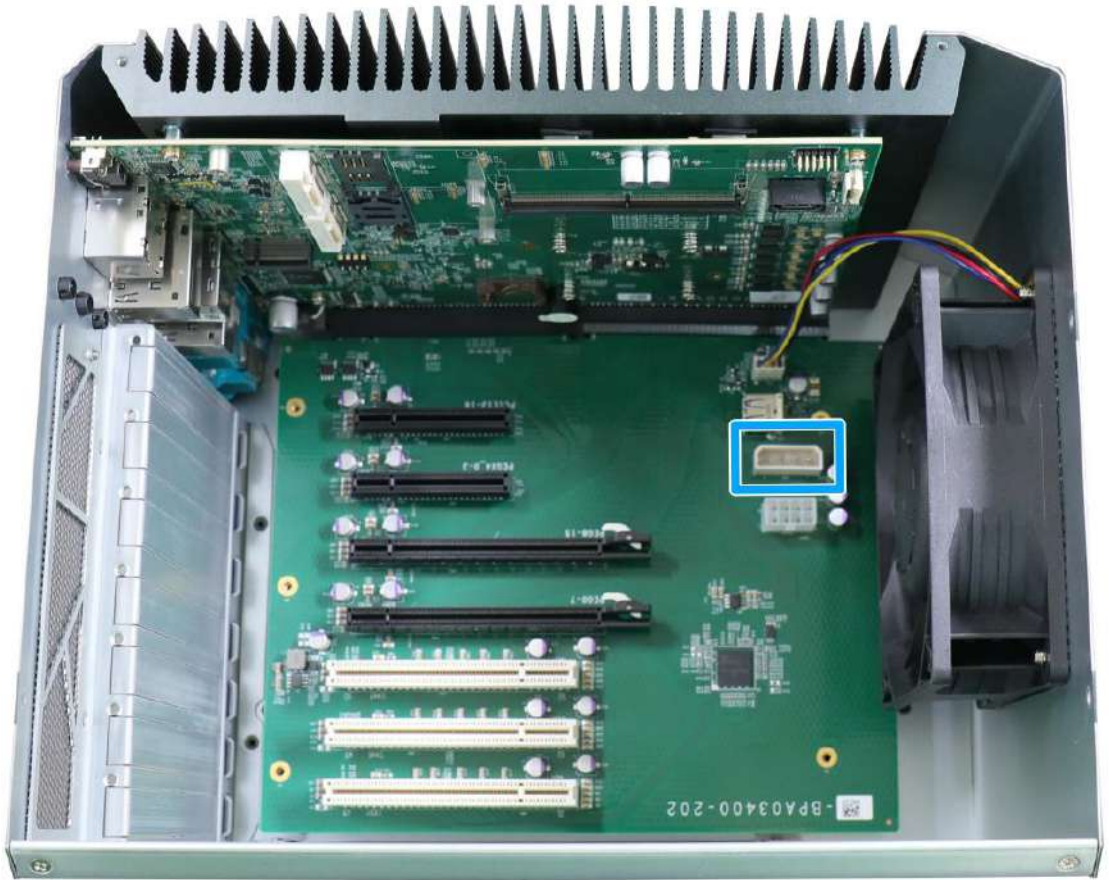

The system's daughter board features a 4-pin connector to supply additional power for users who install add-on PCIe USB3 or Power over Ethernet (PoE) cards that may require extra power delivery.

Pin Definition

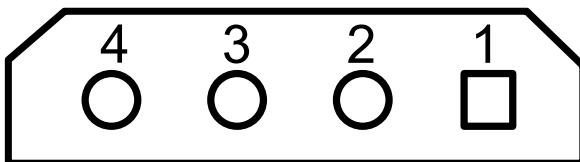

Pin	4	3	2	1
Definition	5V	GND	GND	12V

2.3.7 8-pin Connector for GPU (up to 115W)



The system supports an NVIDIA graphics inference accelerator up to 115W. The 8-pin connector can supply additional power delivery to the graphics card for operation stability.

Pin Definition

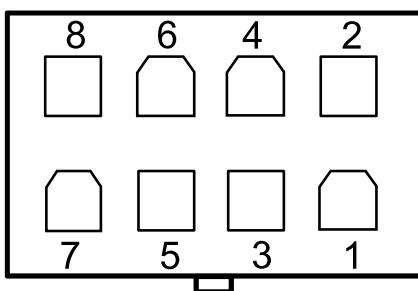

Pin	8	6	4	2
Definition	GND	12V	12V	12V
Pin	7	5	3	1
Definition	GND	GND	GND	GND

2.3.8 Internal USB



The system's daughter board has an internal USB2.0 port on the PCBA. You can utilize this USB port to connect a USB protection dongle inside the chassis of the system.

3 System Installation

Before disassembling the system enclosure and installing components and modules, please make sure you have done the following:

- It is recommended that only qualified service personnel should install and service this product to avoid injury or damage to the system.
- Please observe all ESD procedures at all times to avoid damaging the equipment.
- Before disassembling your system, please make sure the system has powered off, all cables and antennae (power, video, data, etc.) are disconnected.
- Place the system on a flat and sturdy surface (remove from mounts or out of server cabinets) before proceeding with the installation/ replacement procedure.

3.1 Disassembling the System

To access system internal components, the system needs to be disassembled. To disassemble the system enclosure, you need to remove the Chassis and screws on both I/O panels.

1. On the I/O panel, remove the screw indicated.



Nuvo-10007/ 10034



Nuvo-10003

2. Remove the screws indicated on the side panel.



3. Remove the screws indicated on the rear panel.

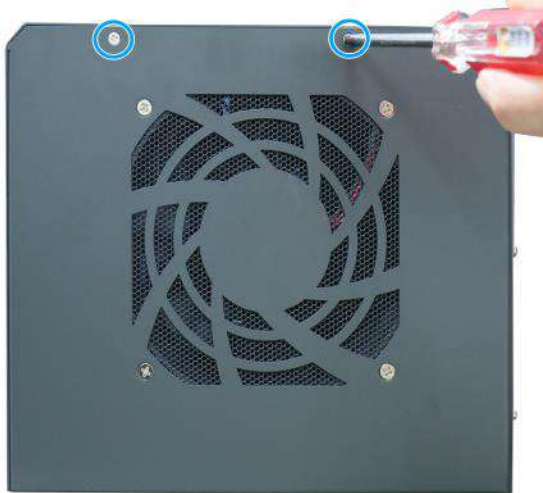

Nuvo-10007/ 10034



Nuvo-10003

4. Gently lift the L-shape cover panel to separate it from the enclosure.



5. Once the L-shaped panel has been removed, you can gain access to all internal expansion slots and components.

3.2 Installing Internal Components

3.2.1 CPU Installation for Barebone System

1. To install the CPU, you will need to separate the heatsink and the motherboard, please refer to the section "[Disassembling the System](#)".
2. Once you have removed the L-shaped panel, looking from the top, remove the screws indicated securing the daughterboard.



3. Disconnect the fan power cable and gently wiggle to disengage the daughterboard from the motherboard.

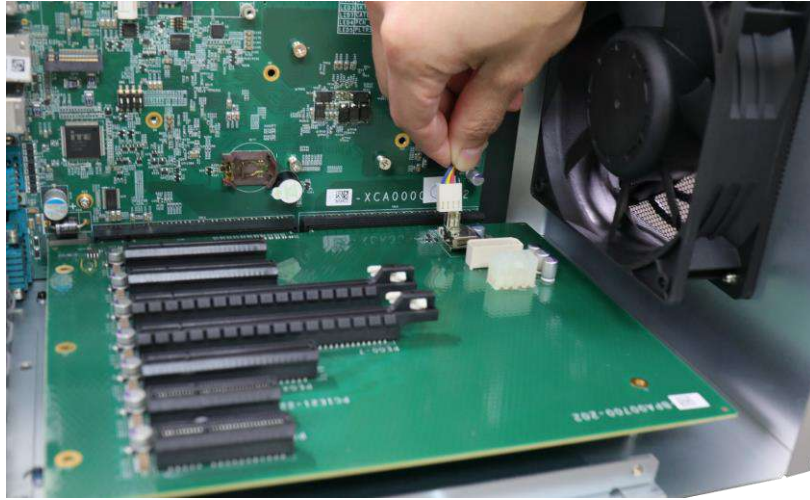

Disconnect fan power cable



NOTE

Please disengage the daughter-board gradually as there are capacitors situated underneath the PCIe slots that may come in contact with enclosure structures when removed with excessive force.

4. Remove the screws indicated on the heatsink.

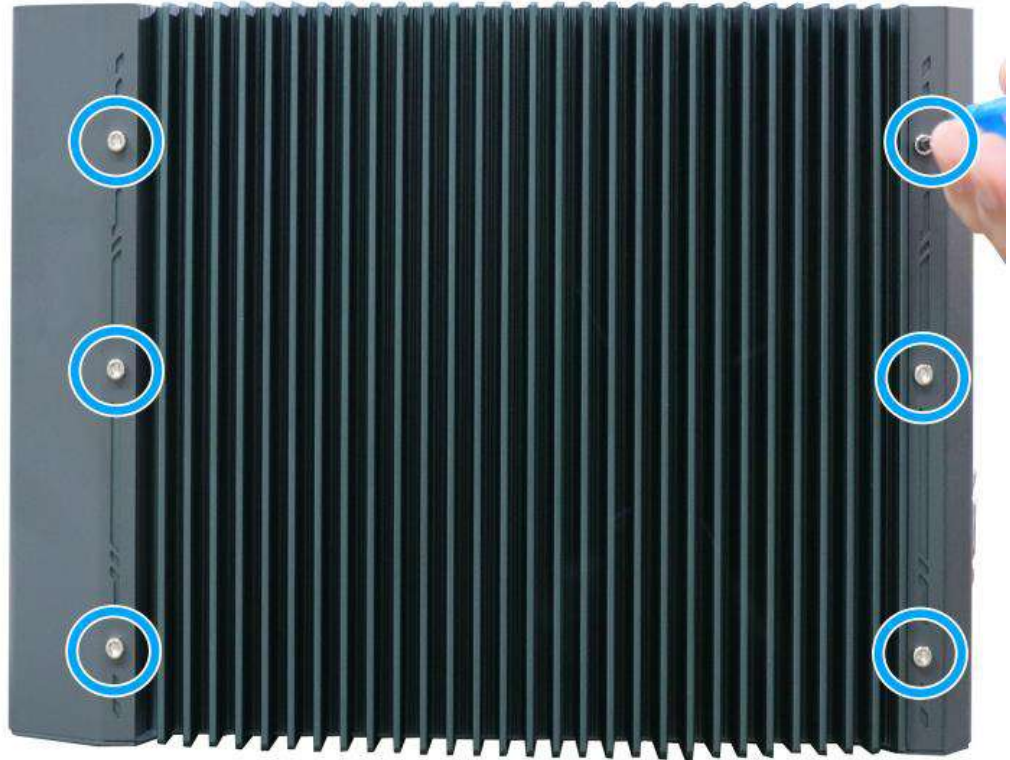

5. Gently lift and separate the motherboard/ heatsink from the enclosure.

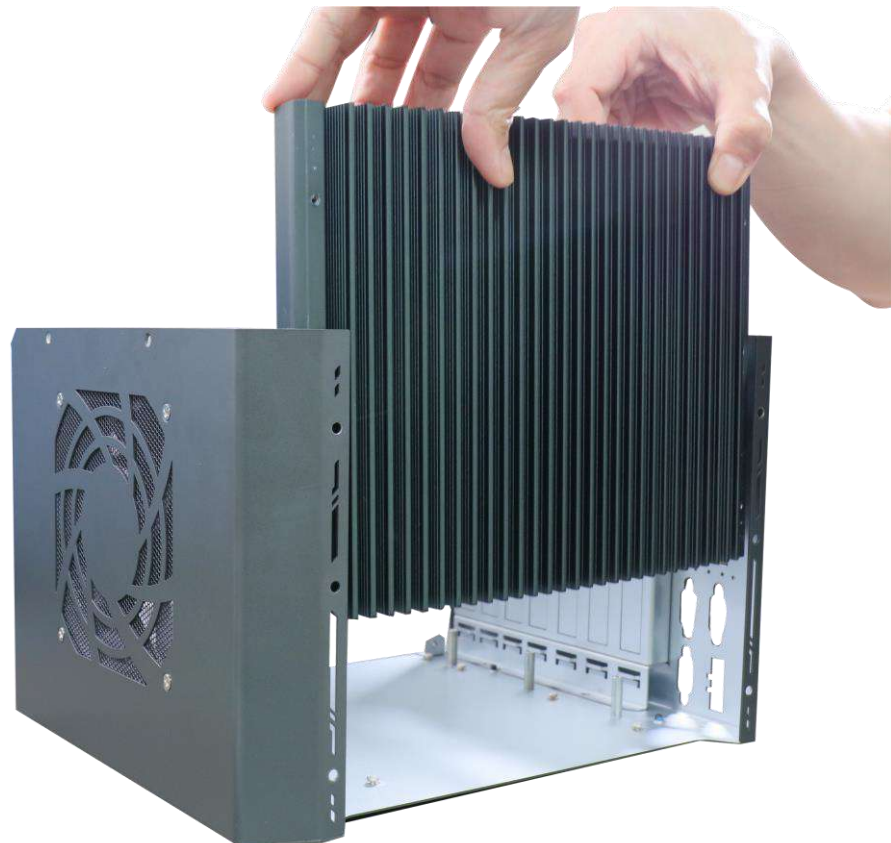

6. To separate the motherboard from the heatsink, remove the screws indicated in **red** to separate the motherboard from the heatsink.

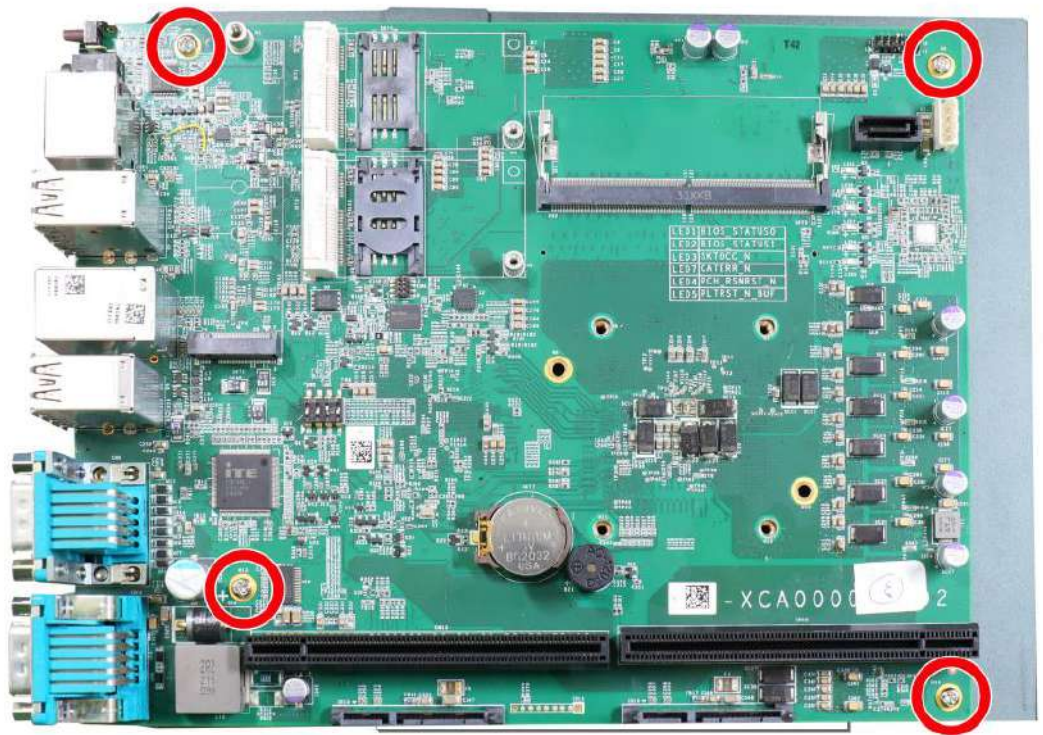

8. Once the motherboard has been separated from the heatsink, turn the motherboard upside-down to access the CPU socket. Gently lift and remove CPU socket protector.

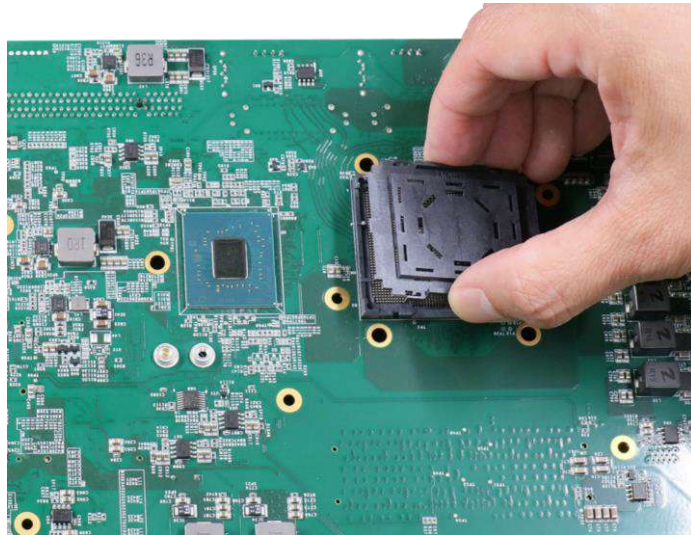

 **WARNING**

With the protective cover removed, please be careful when handling the motherboard. DO NOT touch the pins in the LGA socket!

- Remove the CPU. Remove the CPU from its container/ tray. Match the four notches on the side (indicated by the **blue arrows**) to the protrusions in the socket, gently lower the CPU into the socket. Pay attention to the seating orientation, notice there is a short side (indicated by **green lines**), and a long side (indicated by **red lines**).



- Locate the CPU retention bracket (holder) from the accessory box. Place the retention bracket on the CPU and hold it in place. Make sure the screw holes match the CPU retention bracket's screw holes (indicated by **red circles**).



Screw holes for CPU retention bracket



Place the CPU retention bracket on while matching the screw holes

11. Turn the motherboard around and secure the CPU retention bracket by tightening two M3 P-head screws.

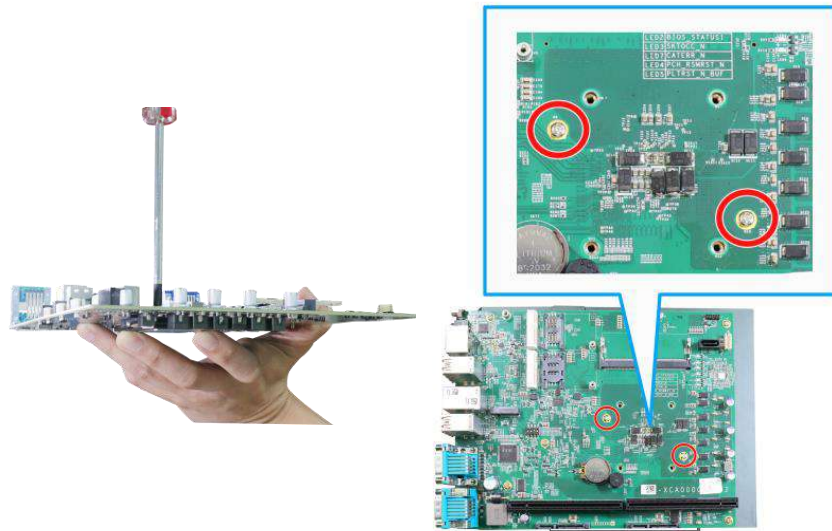

Hold CPU retention bracket firmly and turn the motherboard around

Secure two M3 P-head screws

12. Remove the protector film on the heatsink.

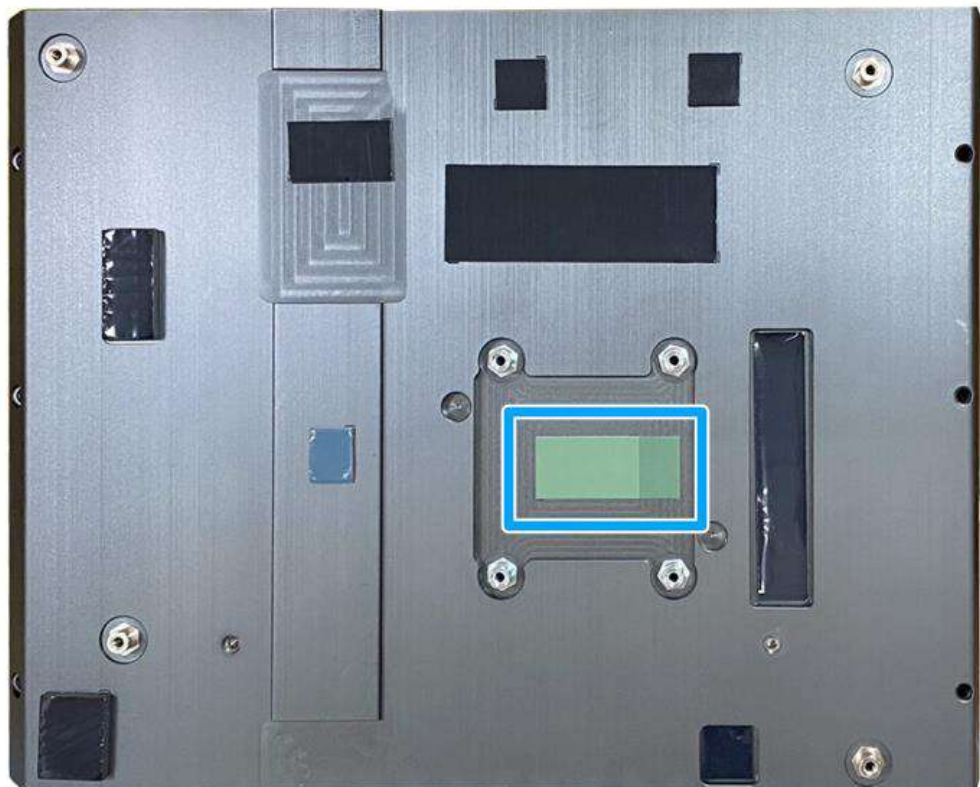

13. With the four motherboard standoffs aligned, gently lower the motherboard onto the heatsink and secure the four screws.

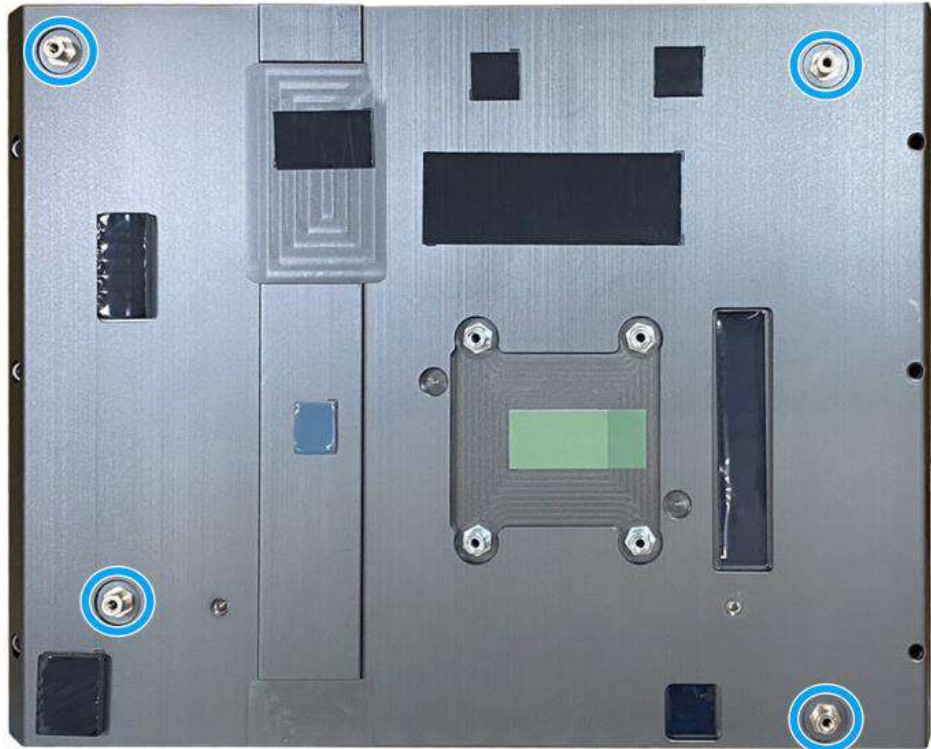

Four standoffs on the heatsink

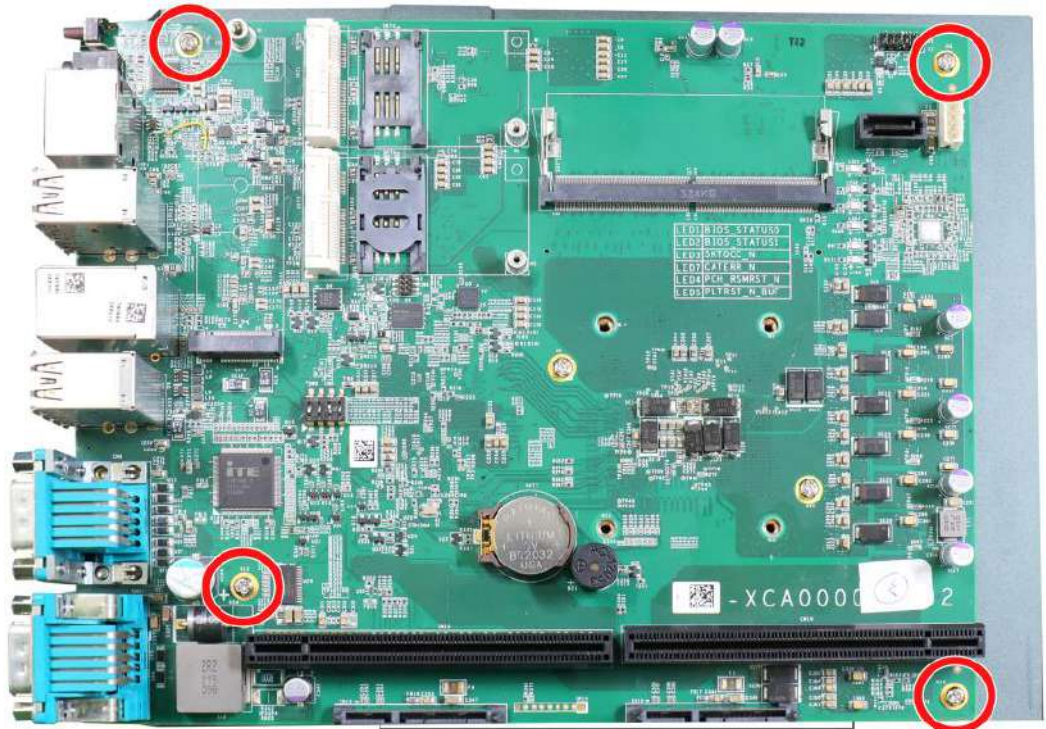

Secure motherboard with screws

- Once the motherboard has been installed, you're ready to secure the screws that help the heatsink apply pressure to the CPU/ chipset die. You'll want to apply even pressure to the corners by gradually tightening each screw. Please refer to the recommended order when tightening the screws.

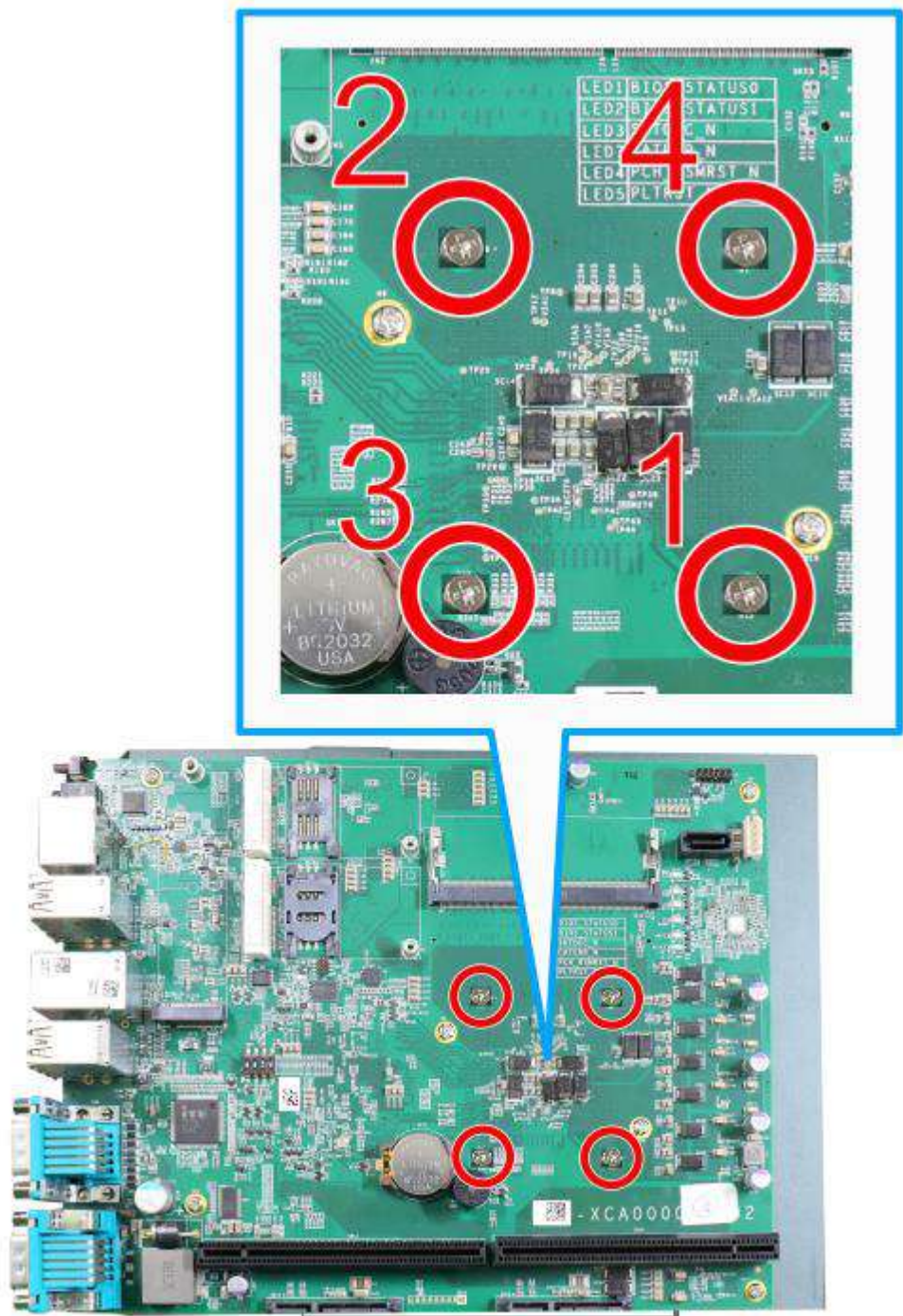

- Reinstall the system enclosure when done.
- If you need to install other components, please refer to respective sections.

3.2.2 Remove and Replace the Existing CPU

1. To replace the existing CPU, you will need to separate the heatsink/ motherboard from the enclosure, please refer to [Disassembling the System](#).
2. To separate the heatsink and the motherboard, remove the eight screws indicated below.

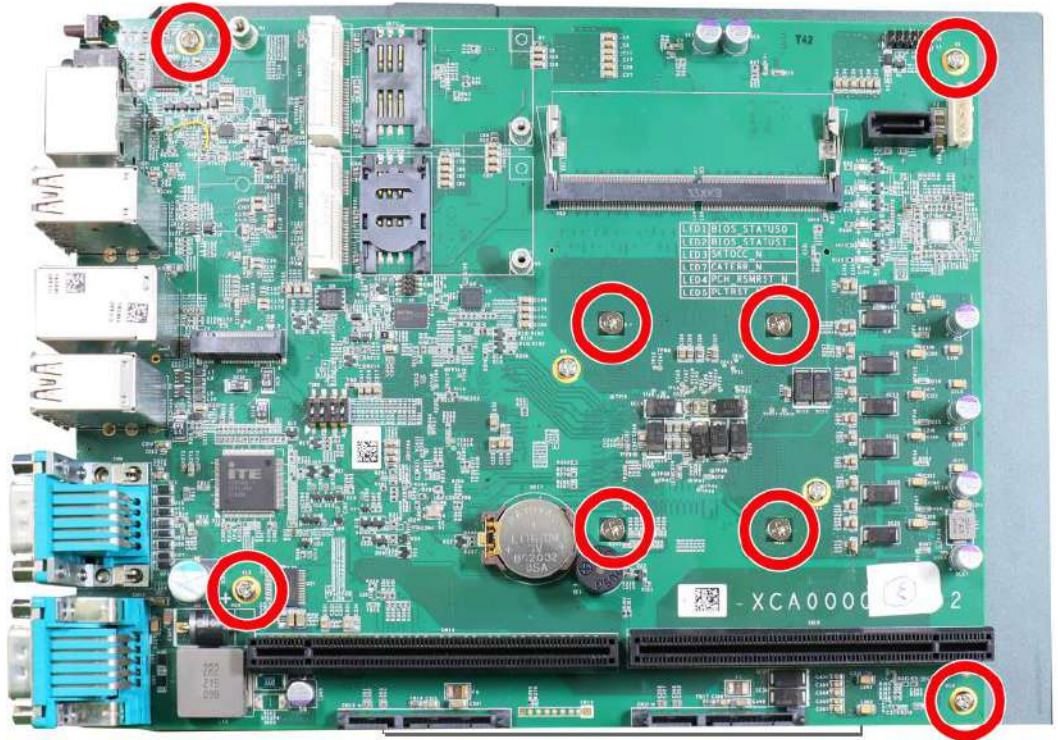

3. Gently separate the motherboard from the heatsink. With a hand on the CPU retention bracket, remove the screws indicated to remove the CPU holder from the CPU.

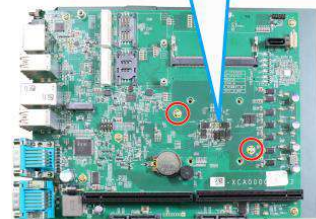
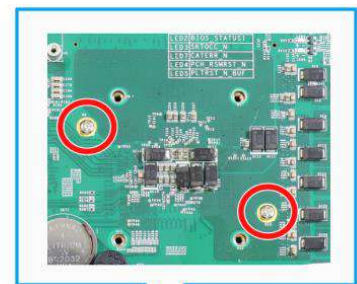

With a hand on the CPU retention bracket

Remove the screws to remove the CPU retention bracket

4. At this point, the CPU and retention bracket may be stuck onto the heatsink (due to the thermal pad). Please use a plastic pry tool and gently separate the CPU/ retention bracket from the heatsink.

 **WARNING**

With the heatsink, CPU, and retention bracket removed, please be careful when handling the motherboard. DO NOT touch the pins in the LGA socket!

5. Gently separate the CPU from the retention bracket, and clean off any thermal pad residues on the heatsink and on the retention bracket.



CPU retention bracket (holder)

 **WARNING**

With the CPU removed, please be careful when handling the motherboard. DO NOT touch the pins in the LGA socket!

6. Place a new CPU thermal pad (indicated in blue) onto the heatsink for the new CPU.

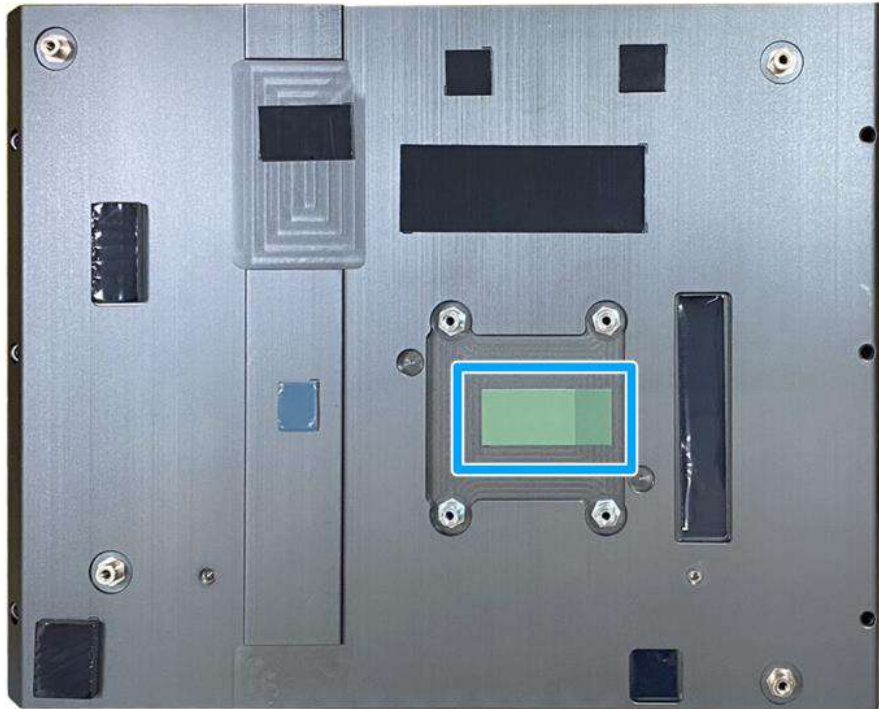

7. Remove and clean off any thermal pad residues around the socket/ motherboard. Gently place the new CPU into the socket by matching the four notches (indicated by blue arrows) on the side to the protrusions in the socket. Pay attention to the seating orientation, notice there is a short side (indicated by green lines), and a long side (indicated by red lines).



8. Make sure all thermal pad residues have been cleaned on both sides of the retention bracket. Place the CPU retention bracket (holder) on top of the CPU and hold it in place. Make sure the screw holes match the CPU retention bracket's screw holes (indicated by **red circles**).



Screw holes for CPU retention bracket



Place the CPU retention bracket on while matching the screw holes

9. Turn the motherboard around and secure the CPU retention bracket by tightening two M3 P-head screws.

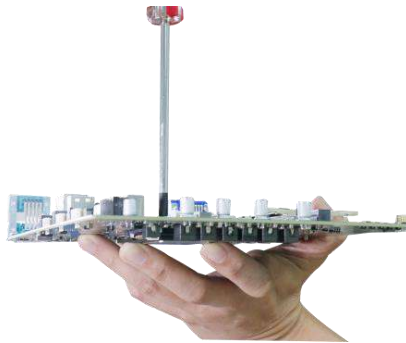

Hold CPU retention bracket firmly and turn the motherboard around

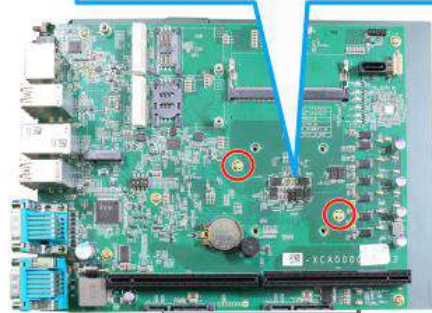
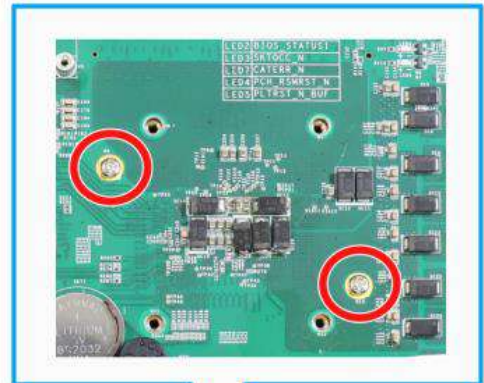

Secure two M3 P-head screws

10. Remove the protector film on the heatsink.

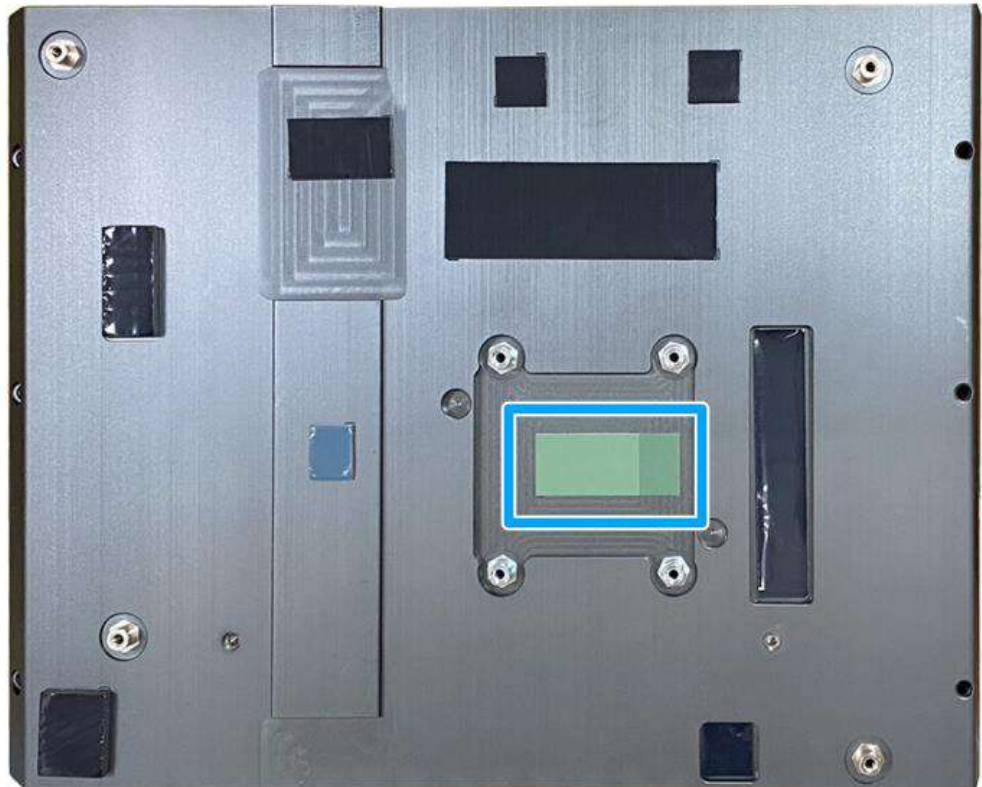

11. With the four motherboard standoffs aligned, gently lower the motherboard onto the heatsink and secure the four screws.

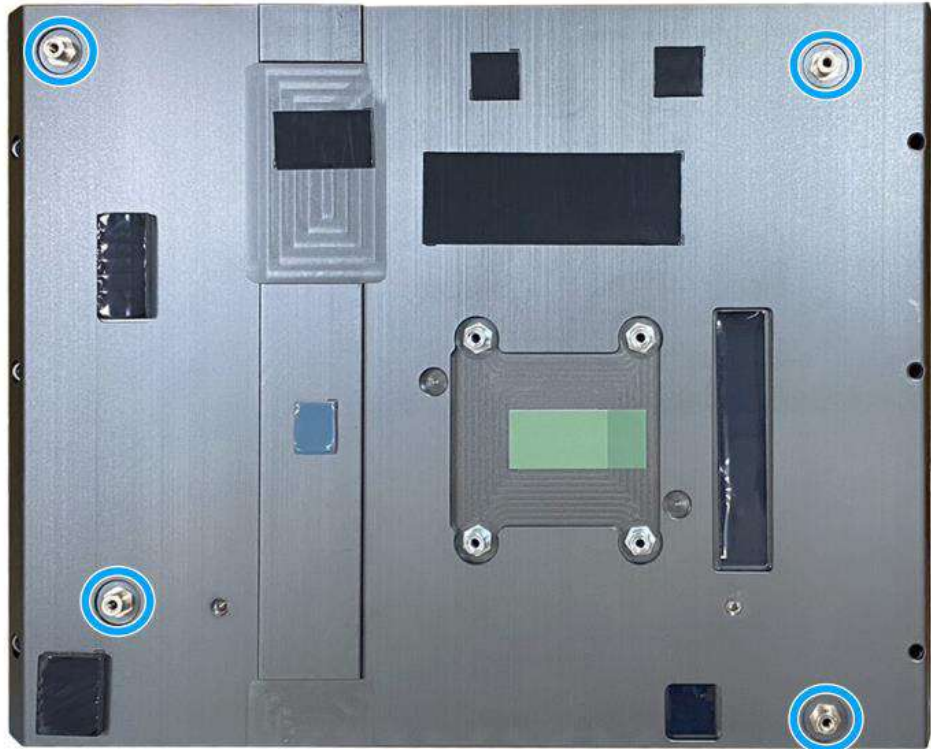

Four standoffs on the heatsink

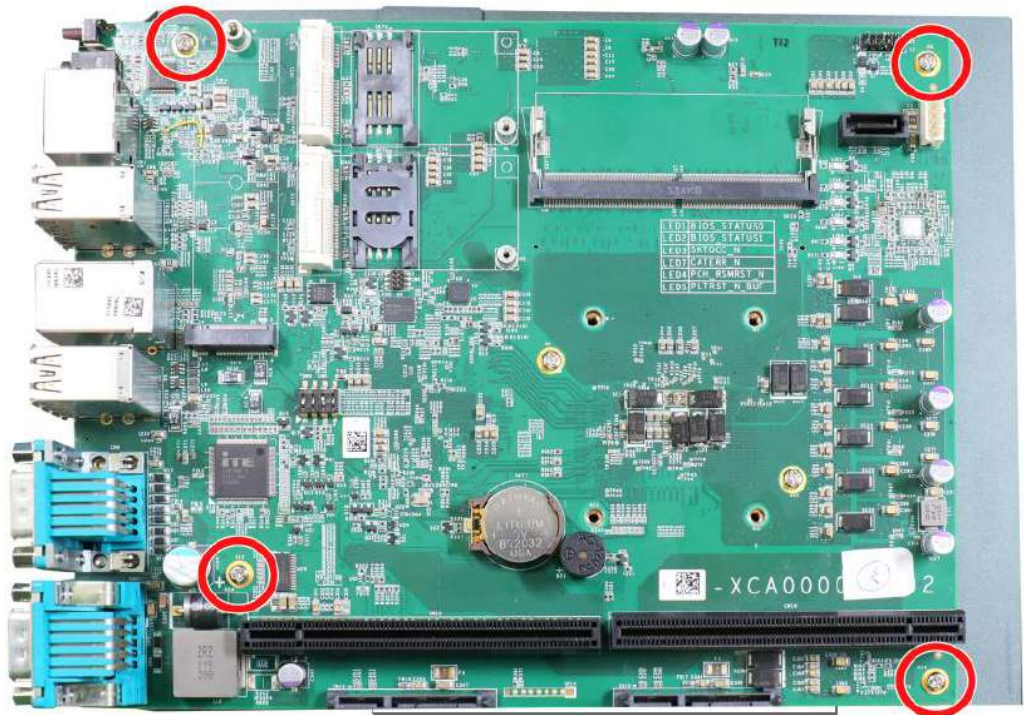

Secure motherboard with screws

- Once the motherboard has been installed, you're ready to secure the screws that help the heatsink apply pressure to the CPU/ chipset die. You'll want to apply even pressure to the corners by gradually tightening each screw. Please refer to the recommended order when tightening the screws.

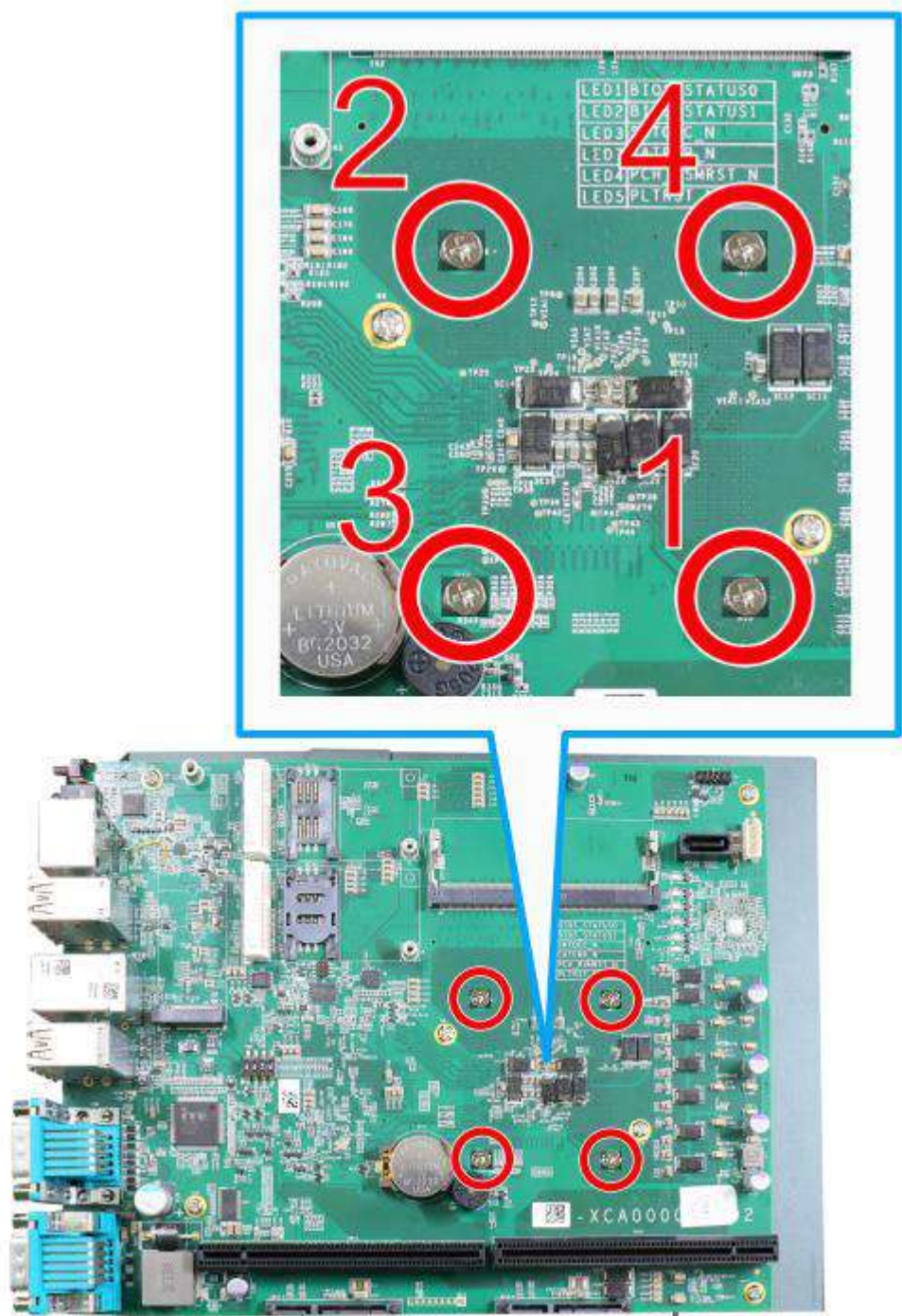

- [Reinstall the system enclosure](#) when done.

If you need to install other components, please refer to respective sections.

3.2.3 DDR5 SO-DIMM Installation

There are two SO-DIMM memory slots (indicated in **blue**) on the motherboard that support a total maximum of 64GB non-ECC DDR5-4800. Please follow the procedures below to replace or install the memory modules.

1. Please refer to the sections "[Disassembling the System](#)" and "[Remove and Replace the Existing CPU](#)" to gain access to the DRAM slot on the CPU socket side.
2. Locate the SODIMM memory module slots on the motherboard.



Expansion slot side

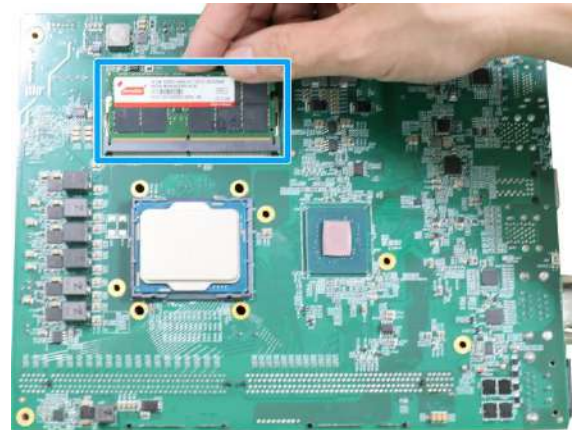

CPU socket side

3. To install the memory module, insert gold fingers into the slot at 45-degree angle, push down on the memory module to clip the module into position.



4. Push the memory module down until it is clipped-in.



5. If you are installing the memory module on the CPU socket side, please remember to

remove the thermal pad protection film indicated below.

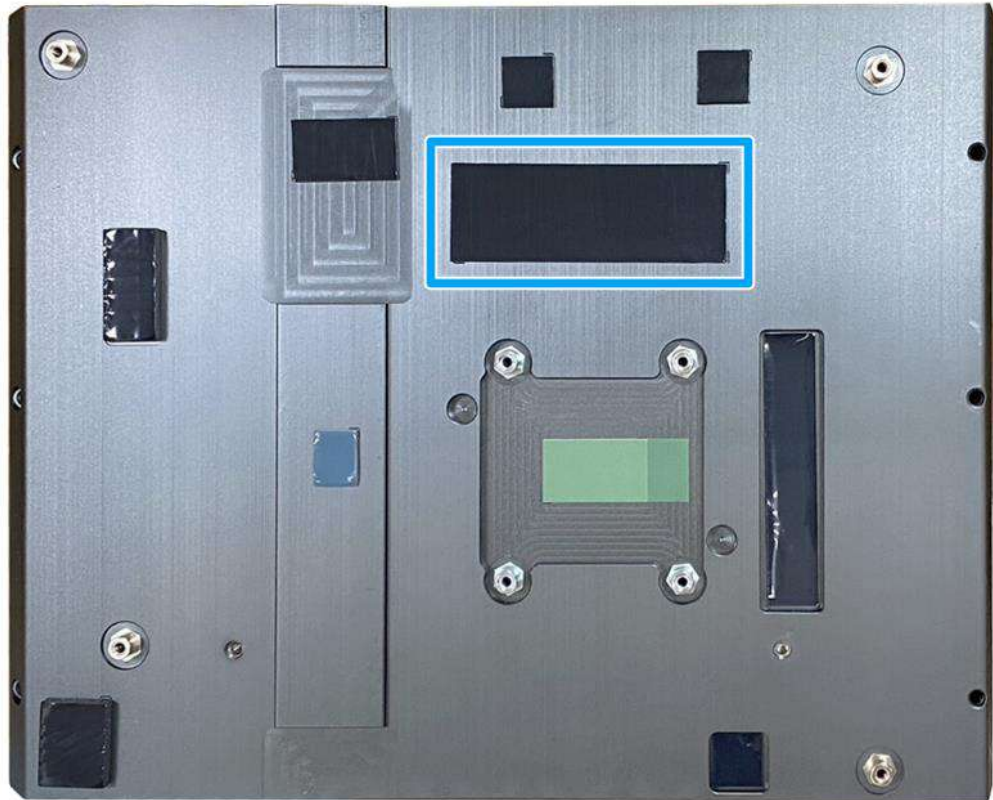

6. Repeat steps 3 and 4 to install the other module.
7. [Reinstall the system enclosure](#) and panel when done.

If you need to install other components, please refer to respective sections.

3.2.4 M.2 2280 M Key SATA SSD Installation



NOTE

The M.2 slot is only compatible with SATA signal M.2 SSD only.

The system supports an M.2 2280 slot for you to install an M.2 SATA SSD for faster access over traditional hard disk drives. Please follow the procedures below to install an M.2 SATA SSD.

1. Please refer to the section "[Disassembling the System](#)".
2. Locate the M.2 M key slot on the motherboard.



3. Insert the module on a 45 degree angle.



4. Gently press down and secure the module with an M3 P-head screw.



5. [Reinstall the system enclosure](#) when done.
If you need to install other components, please refer to respective sections.

3.2.5 mini-PCIe slot, Mini-SIM (2FF) Card and Antenna Installation

The system has two mini-PCIe slots (indicated in **blue**) coupled with mini-SIM socket (indicated in **red**) for installing 4G/ 5G module. For installation, please refer to the following instructions.

1. Please refer to the section "[Disassembling the System](#)".
2. Locate the mini-PCIe and SIM slots on the motherboard.

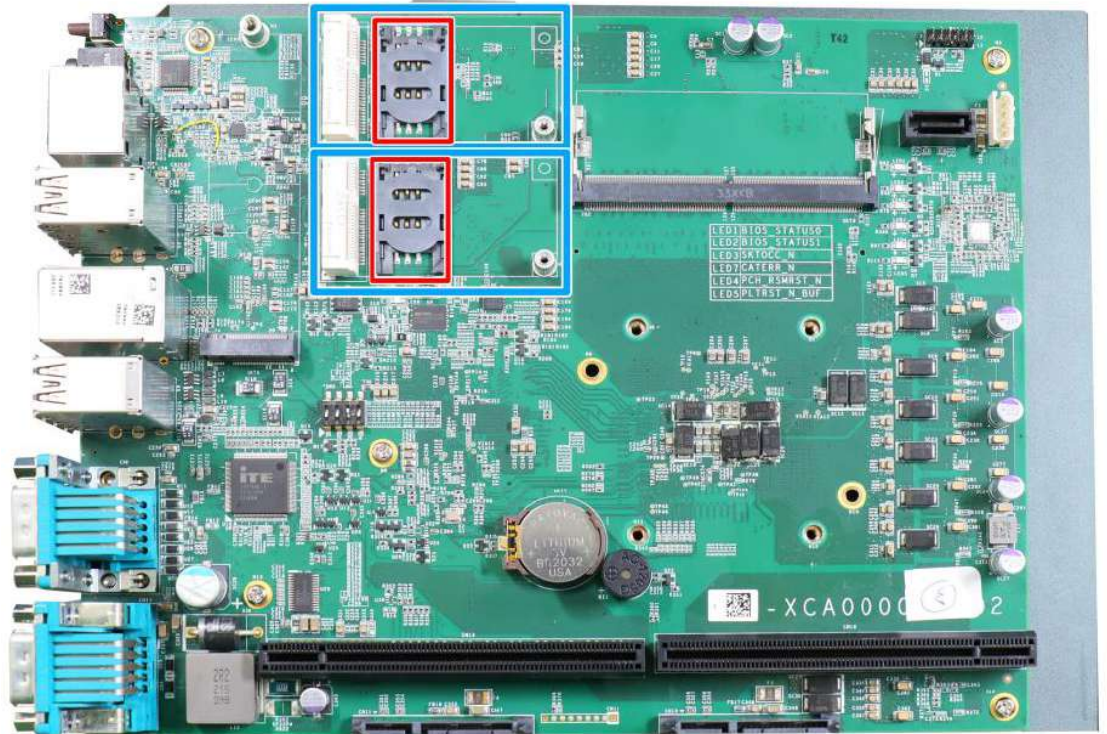

3. Before installing the module, you need to insert the mini-SIM card. Slide the SIM slot holder and lift the SIM card holder. Insert the Mini-SIM card (pins facing up), shut the SIM holder and slide it to lock the SIM card in-place.

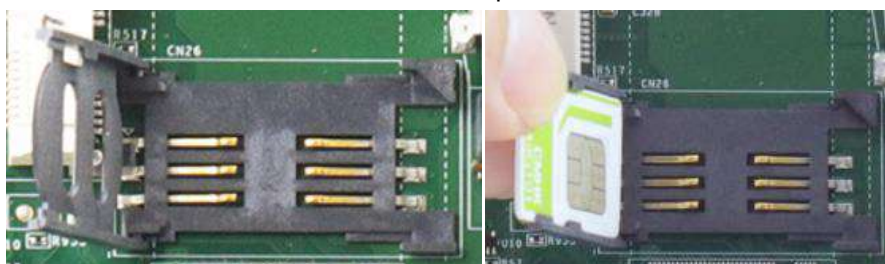

Slide and lift SIM card holder

Insert SIM card with pins facing up

4. Secure the SIM card by sliding the holder.



5. Insert the module on a 45 degree angle into the slot and secure the module with an M3 P-head screw.



Insert on 45 degree angle

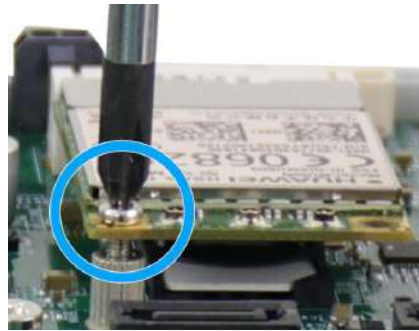

Secure the module

6. Clip on the IPEX-to-SMA cable to the module and secure the antenna to the front or rear panel. Please refer to the module's manual for clip-on connection.



Clip on IPEX-to-SMA cable

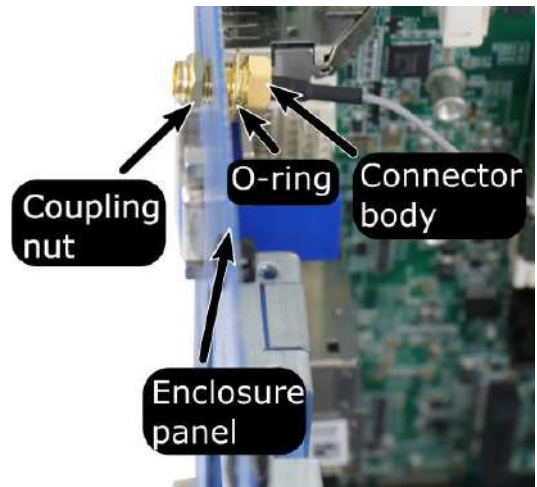

Secure antenna to rear panel

7. Secure the external antenna to complete the installation.



8. [Reinstall the system enclosure](#) and panel when done.

If you need to install other components, please refer to respective sections.

3.2.6 HDD/ SSD Installation



NOTE

Supports up to 15mm thickness HDD/ SSD.

The system has three SATA ports (indicated in **blue**). Please refer to the following instructions on how to install 2.5" SATA HDD/ SSD.

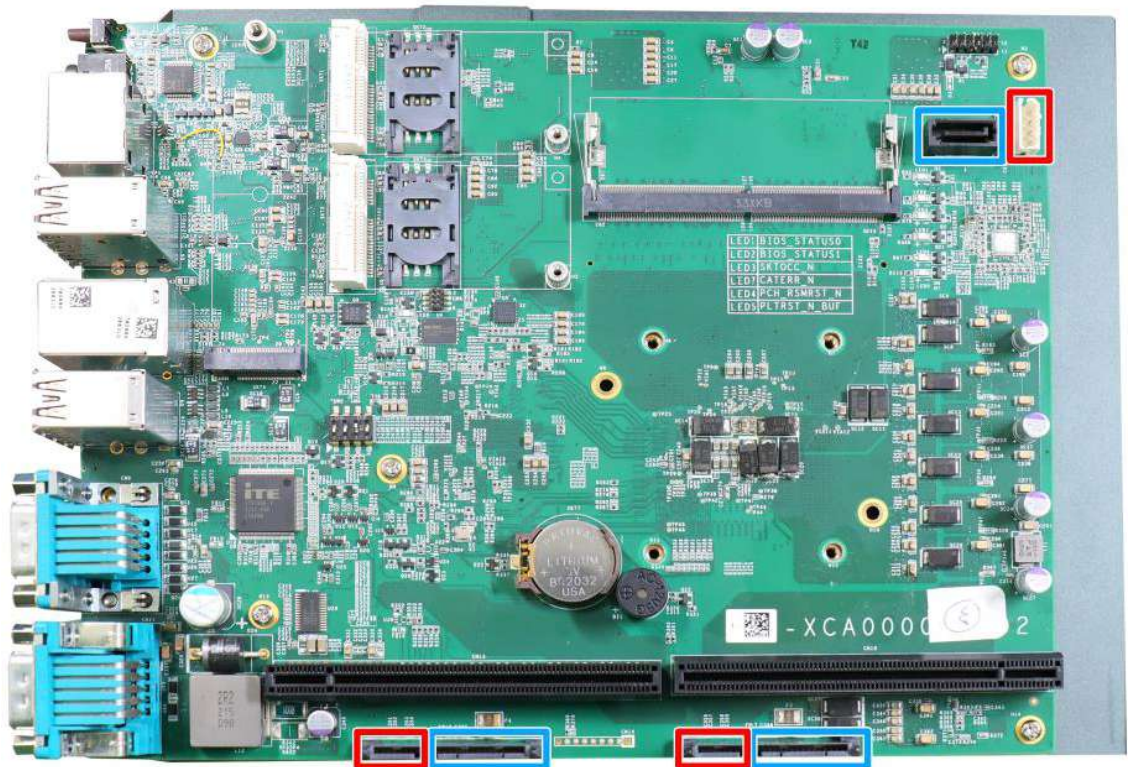

1. Please refer to the section "[Disassembling the System](#)".
2. The HDD/ SSD tray is situated at the bottom, just underneath the daughterboard. You do not have to remove the daughterboard to retrieve the tray, but the daughterboard has been removed to better illustrate the procedure.



Remove the screws indicated



Pull out the tray

3. With the SATA connectors facing inwards (indicated in blue), secure the HDD/ SSD with flathead screws from underneath the tray. You may install just one or two HDDs/ SSDs.



SATA connectors facing inwards **Secure underneath with flathead screws**

4. Once the HDDs/ SSDs have been secured, insert the tray 3/4 of way in, firmly and gently push the tray into place. When HDDs/ SSDs have properly engaged the connector, secure the screws holding the tray in place.



5. [Reinstall the system enclosure](#) and panel when done.
If you need to install other components, please refer to respective sections.

3.2.7 On/ Off Control & Status LED Cable Installation (Optional)

When the system is placed inside a cabinet, it's useful to connect the on/ off controls and the system status to the external panel. Nuvo-10000 provides a 2x6, 2.0mm pitch pin header to output system status such as power, HDD, watchdog timer, and control system on/off remotely. To install the optional cable, please refer to the following procedure:

1. Please refer to the section "[Disassembling the System](#)".
2. Locate the 2x6 pins for On/Off control & Status LED output on the top right corner of the motherboard.



3. Remove the reserved punch-out panel on the I/O panel.



- Note the pin order, and make sure Pin 1 on cable (indicated in blue) is plugged into Pin 1 on the motherboard (indicated in red).

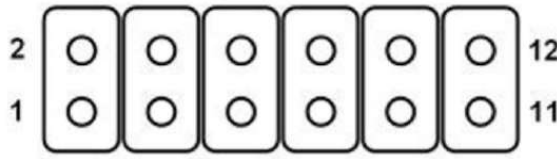

Pin allocation on motherboard

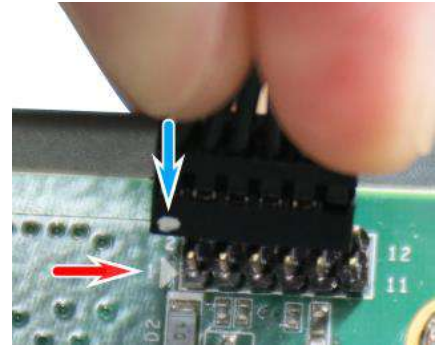

Pin 1 (cable) plugged into Pin 1 (MB)

- When inserting the connector to the I/O panel, make sure the orientation of the plug matched the I/O panel.

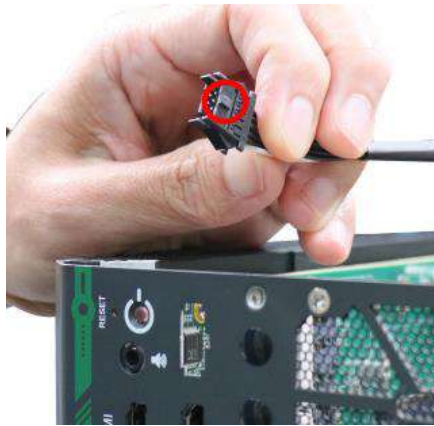

- Push the plug inside-out, make sure it is clipped onto the I/O panel to complete the optional cable installation.

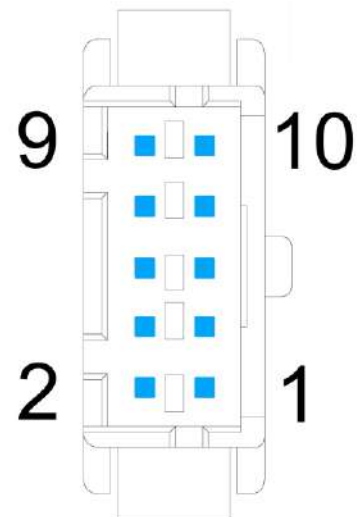

- For front panel pin definitions, please refer to this [section](#).
- [Reinstall the system enclosure](#) and panel when done.

If you need to install other components, please refer to respective sections.

3.3 Installing the System Enclosure

1. To reinstall the system enclosure, place the L-shaped panel back onto the system enclosure frame.



2. Secure the screw indicated on the I/O panel.



Nuvo-10007/ 10034



Nuvo-10003

3. Secure the screws indicated on the side panel.



4. Secure the screw indicated at the rear to complete the enclosure installation.



Nuvo-10007/ 10034



Nuvo-10003

3.4 Wall-mount Bracket Installation

To install the wall-mount bracket, turn the system upside-down and secure the wall-mount bracket onto the bottom of the system enclosure. The bracket and screws can be found in the accessory box.

1. Secure the wall-mount bracket (in **blue**) with the supplied M4 screws (in **red**).

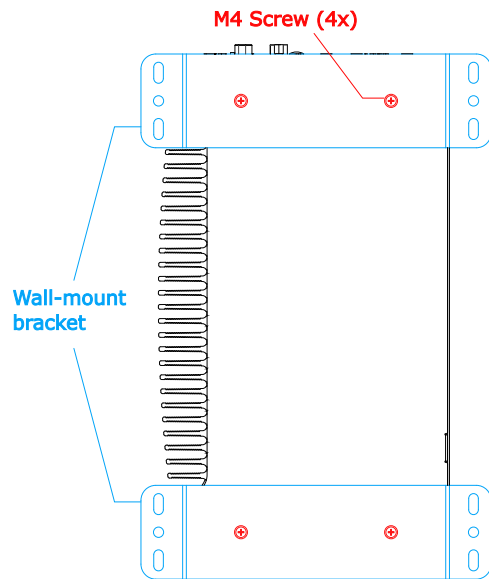

Nuvo-10003

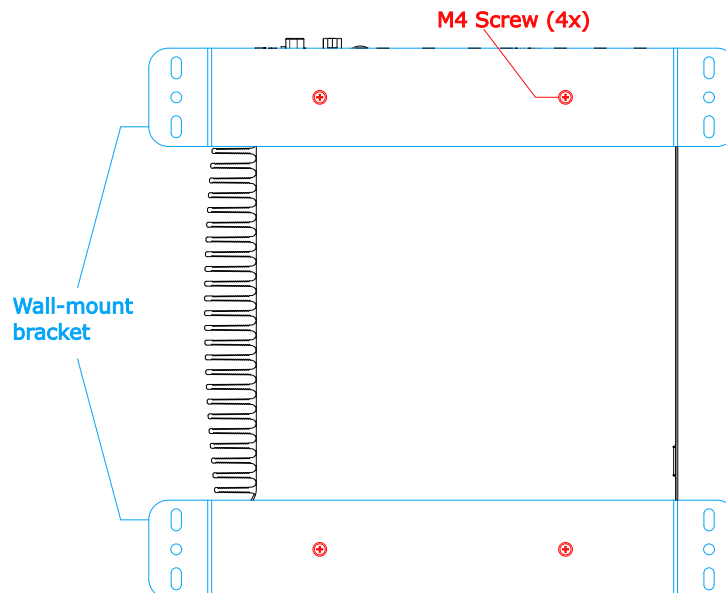

Nuvo-10007/ 10034

2. Place the system on a flat surface and secure it with screws.

3.5 Powering On the System

There are three methods to power on the system

- Pressing the power button
- Sending a LAN packet via Ethernet (Wake-on-LAN)

3.5.1 Powering On Using the Power Button

This is the simplest way to turn on your system. The power button is a non-latched switch and behaves as the ATX-mode on/off control. With DC power connected, pushing the power button will turn on the system and the PWR LED indicator will light up. Pushing the button when system is on will turn off the system. If your operating system supports ATX power mode (i.e. Microsoft Windows or Linux), pushing the power button while the system is in operation will result in a pre-defined system behavior, such as shutdown or hibernation.

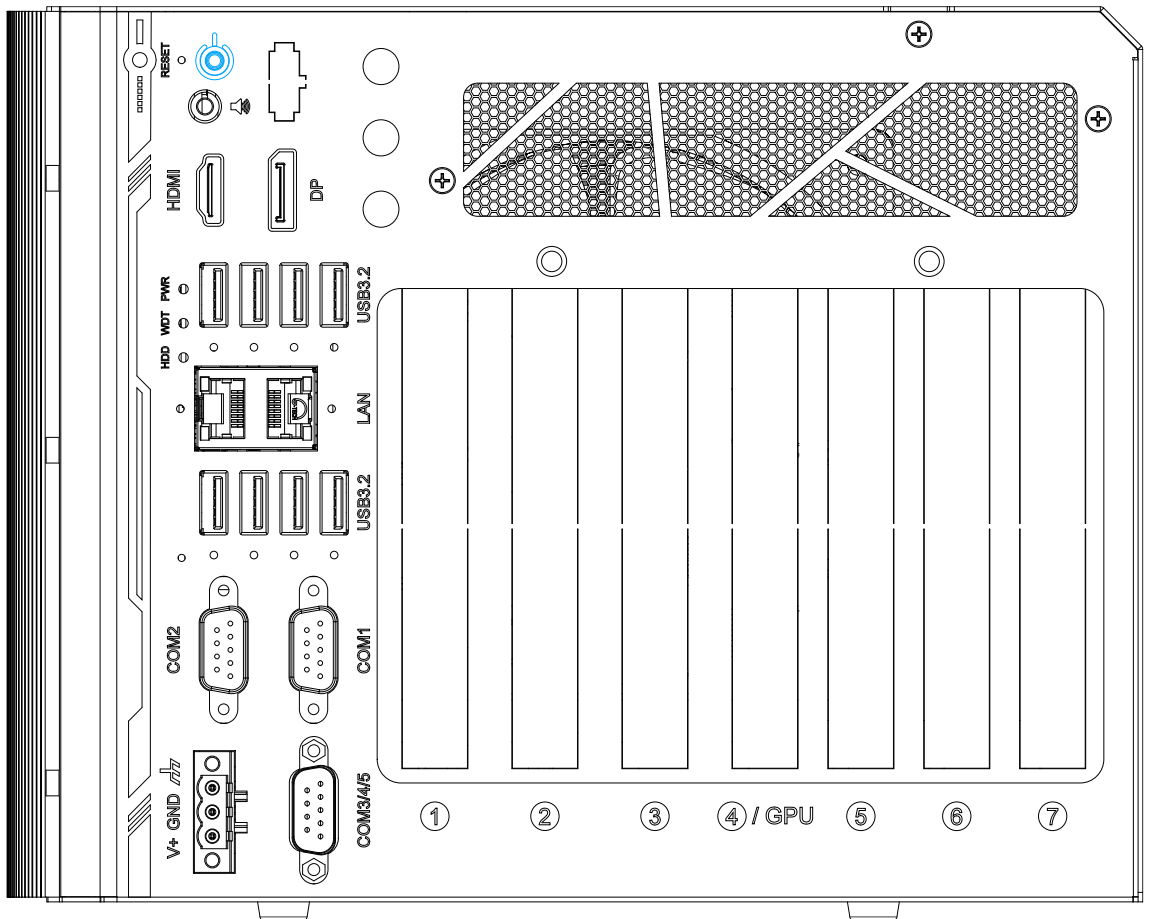

3.5.2 Powering On Using Wake-on-LAN

Wake-on-LAN (WOL) is a mechanism to wake up a computer system from a S5 (system off with standby power) state via issuing a magic packet. The system's Wake-on-LAN compatible GbE port is shown below.

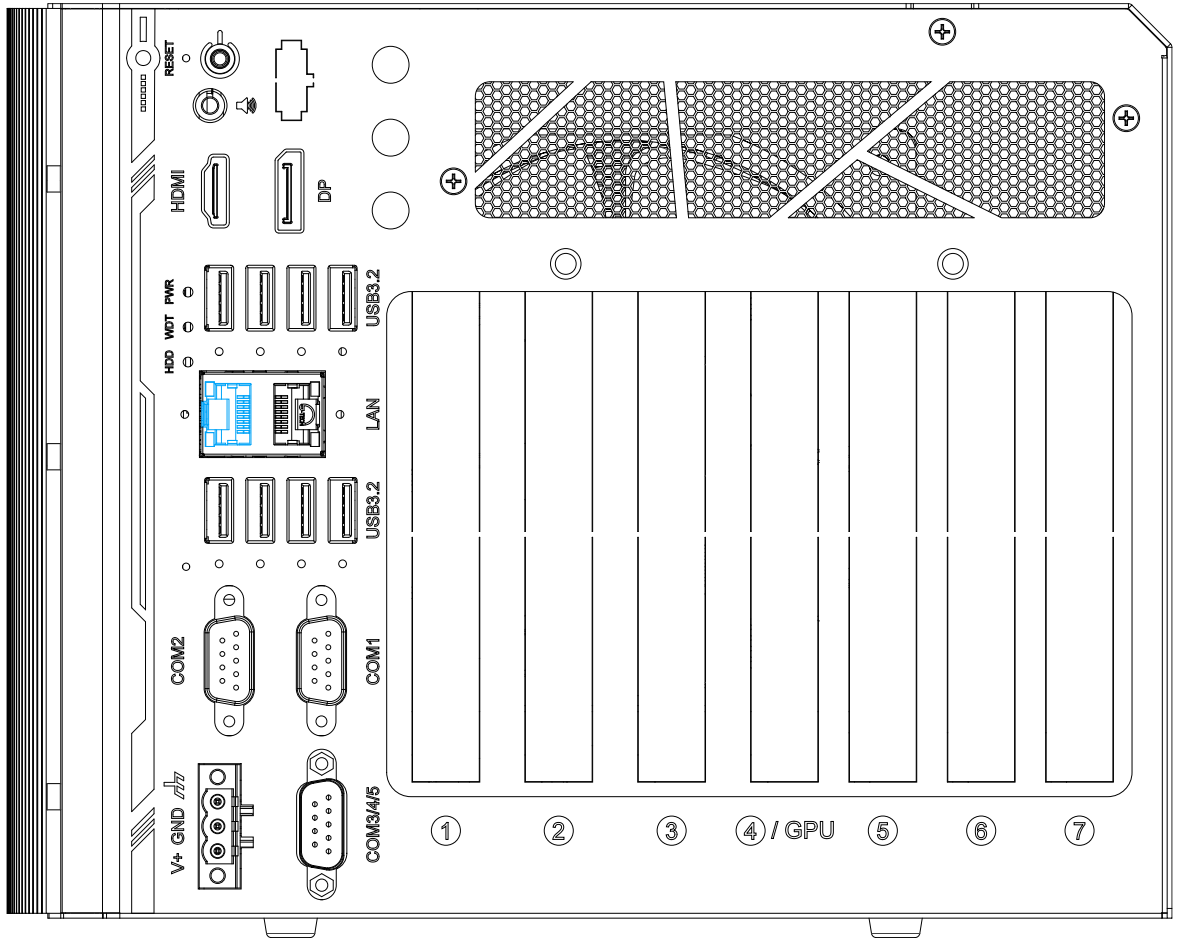

NOTE

Please make sure the Intel chipset and Ethernet driver has been properly installed prior to setting up WOL function.

To enable WOL function, please set up WOL settings in the BIOS and in the operating system by follow the steps described below.

1. When the system boots up, press F2 to enter BIOS setup utility.
2. Go to the **[Power]>[Wake On LAN]** and set it to **[Enabled]**.
3. Press F10 to **“Save changes and exit BIOS”** and allow the system boot into the operating system.

4. Once booted into the Windows system, press “**Windows key + E**”, right-click on “**Network>Properties>Change adapter settings**”. Locate and double-click on the adapter Intel® I219 Gigabit Network Connection, click on **Configure...**
5. Click on the **Power Management** tab and check the following options. Click on OK when done.

Magic Packet

The magic packet is a broadcast frame containing anywhere within its payload 6 bytes of all 255 (FF FF FF

FF FF FF in hexadecimal), followed by sixteen repetitions of the target computer's 48-bit MAC address.

For example, NIC's 48-bit MAC Address is 78h D0h 04h 0Ah 0Bh 0Ch
 DESTINATION SOURCE MISC
 FF FF FF FF FF FF

```

78 D0 04 0A 0B 0C 78 D0 04 0A 0B 0C
0C
78 D0 04 0A 0B 0C 78 D0 04 0A 0B 0C
0C
78 D0 04 0A 0B 0C 78 D0 04 0A 0B 0C
0C
78 D0 04 0A 0B 0C 78 D0 04 0A 0B 0C
0C
78 D0 04 0A 0B 0C 78 D0 04 0A 0B 0C
0C
78 D0 04 0A 0B 0C 78 D0 04 0A 0B 0C
0C
78 D0 04 0A 0B 0C 78 D0 04 0A 0B 0C
0C
MISC   CRC
    
```

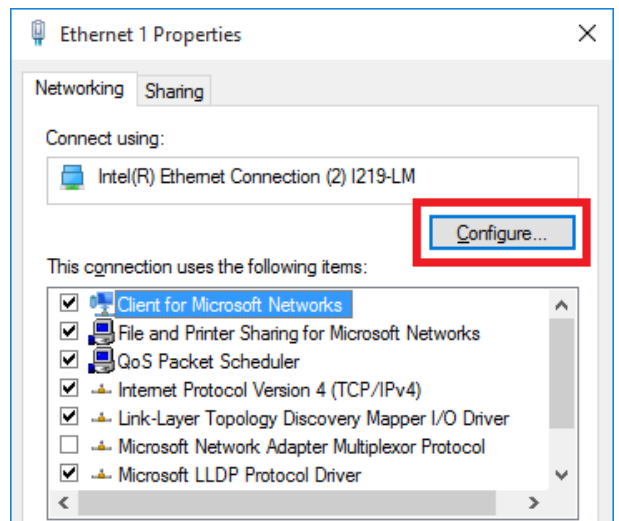
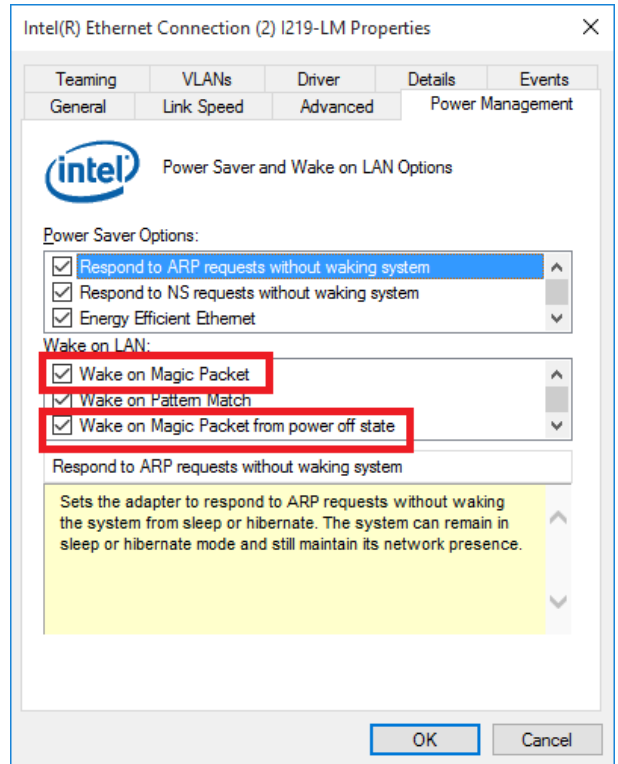

There are some free tools available on Internet that can be used to send a magic packet. Please refer to the following link to understand more about [Magic Packet](#).

3.5.3 Configure your Windows system

When applying ignition power control to your system, please make sure you've configured your Windows system to initiate a shutdown process when pressing the power button. By default, Windows 7/ 8/ 10 goes to sleep (S3) mode when power button is pressed. As sleep (S3) is not a complete shutdown behavior, the ignition control function does not recognize the finish of a normal shut down process and thus users will encounter a system hard-off (power cut-off after 10 minutes). Please configure "When I press the power button" to "Shut down" in your Windows system settings.

Power button settings

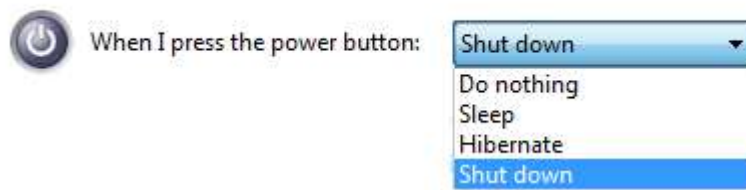

4 System Configuration

4.1 BIOS Settings

The system is shipped with factory-default BIOS settings meticulously programmed for optimum performance and compatibility. In this section, we'll illustrate some of BIOS settings you may need to modify. Please always make sure you understand the effect of change before you proceed with any modification. If you are unsure of the function you are changing, it is recommended to change one setting at a time to see its effect(s).

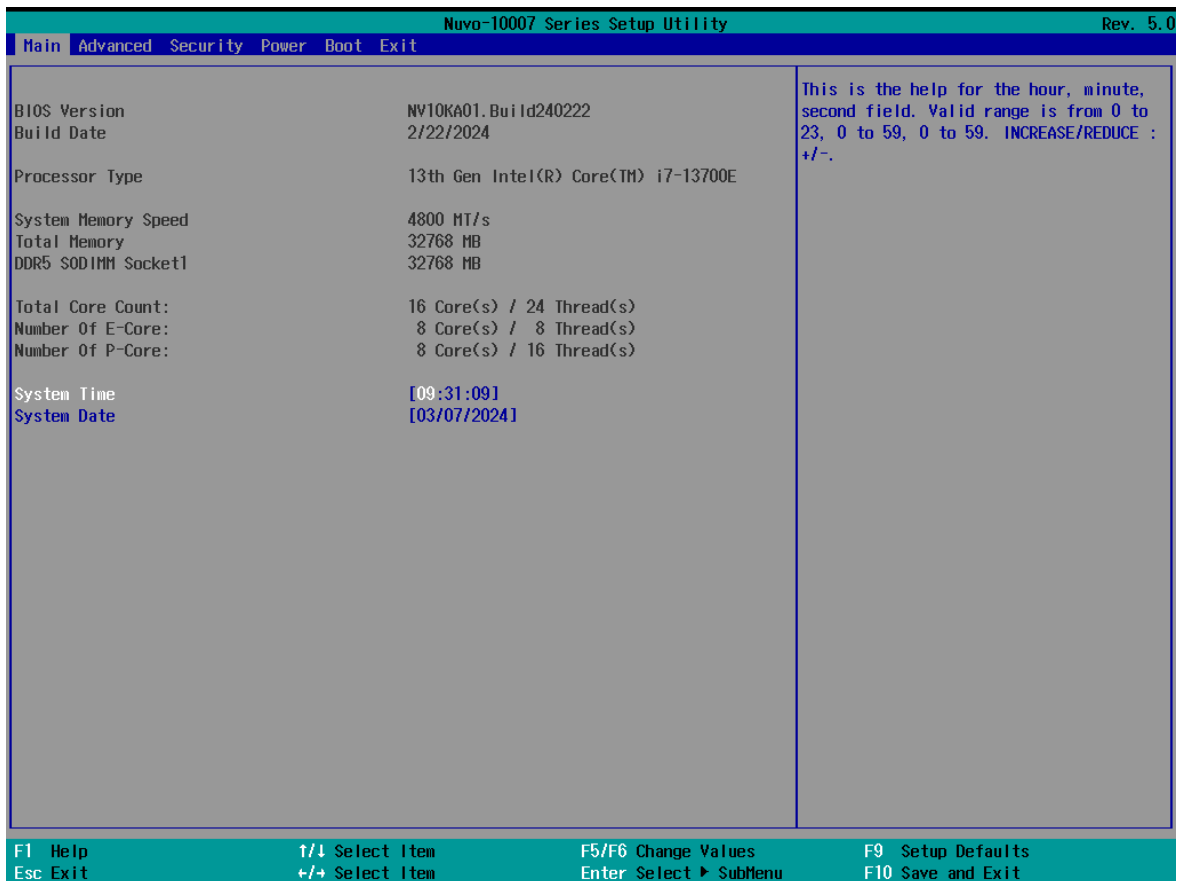

 **NOTE**

Not all BIOS settings will be discussed in this section. If a particular setting/ function you are after requires specific BIOS settings but is not discussed in this section, please contact Neusys Technical Support staff.

4.1.1 COM Port Configuration

The system's [COM1/COM2](#) ports support RS-232 (full-duplex), RS-422 (full-duplex) and RS-485 (half-duplex) mode. You can set the COM1 operating mode via BIOS settings. Another option in BIOS called “*Slew Rate*” defines how sharp the rising/falling edge is for the output signal of COM1. For long-distance RS-422/485 transmission, you may set the “*Slew Rate*” option as “High” to improve signal quality. For RS-422/485 communication, the “*RS-422/485 Termination*” option determines whether to enable/disable internal termination of RS-422/485 transceiver according to your wiring configuration (e.g. with or without external termination).

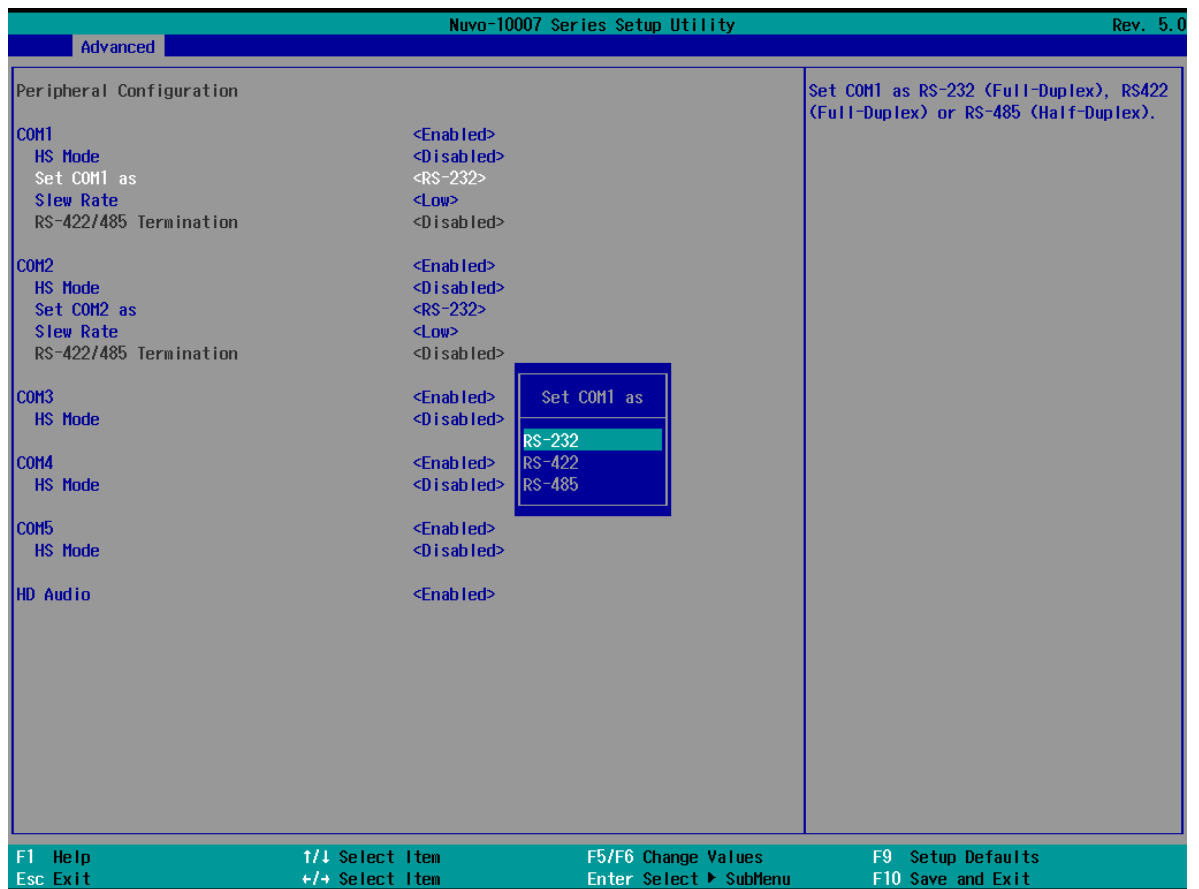

To set COM port operating mode:

1. Press **F2** when the system boots up to enter the BIOS setup utility.
2. Go to **[Advanced]** → **[Peripheral Configuration]**.
3. Set the **[Set COM1 Mode as]** option to the desired mode.
4. Once set, press **F10** to save setting and exit.

4.1.2 COM Port High Speed Mode

The high speed mode of each COM port effectively allows for the port's baud rate generator to operate at 8x the speed with an effective baud rate of 921,600 bps (115,200 x 8). Please refer to the following instructions on how to enable the high speed mode for your COM port (COM1 used as an example).

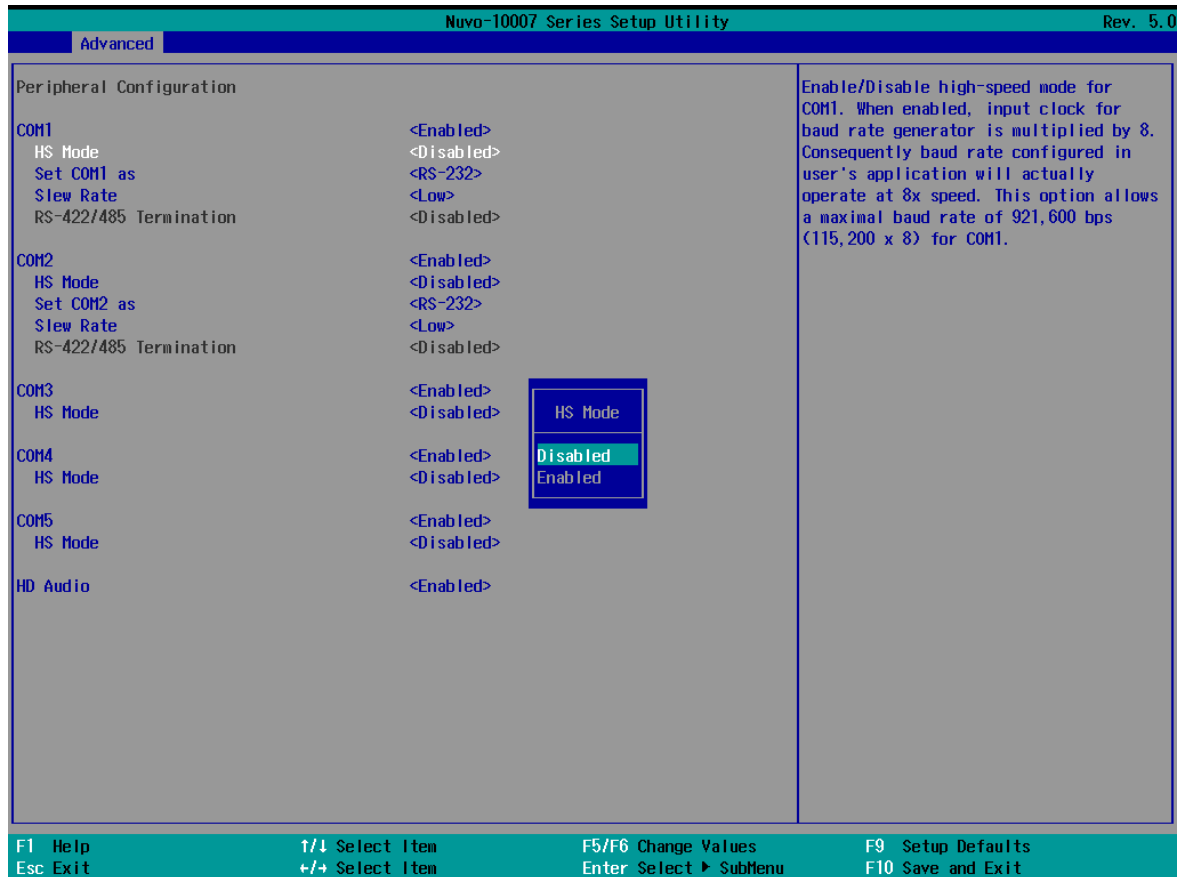

To set COM port high speed mode:

1. Press **F2** when the system boots up to enter the BIOS setup utility.
2. Go to **[Advanced] > [Peripheral Configuration]**.
3. Enable or set the **[Set COM1 Mode as]** option to the desired mode.
4. Highlight **[HS Mode]** and press ENTER to bring up options, highlight **[Enable]** and press ENTER.
5. Once set, press **F10** to save setting and exit.

4.1.3 Delay for PEG Initialization

This setting offers delay in milliseconds for PEG port initialization and PCI enumeration. By increasing the delay value, it may eliminate compatibility issue(s) with some PCIe add-on cards.

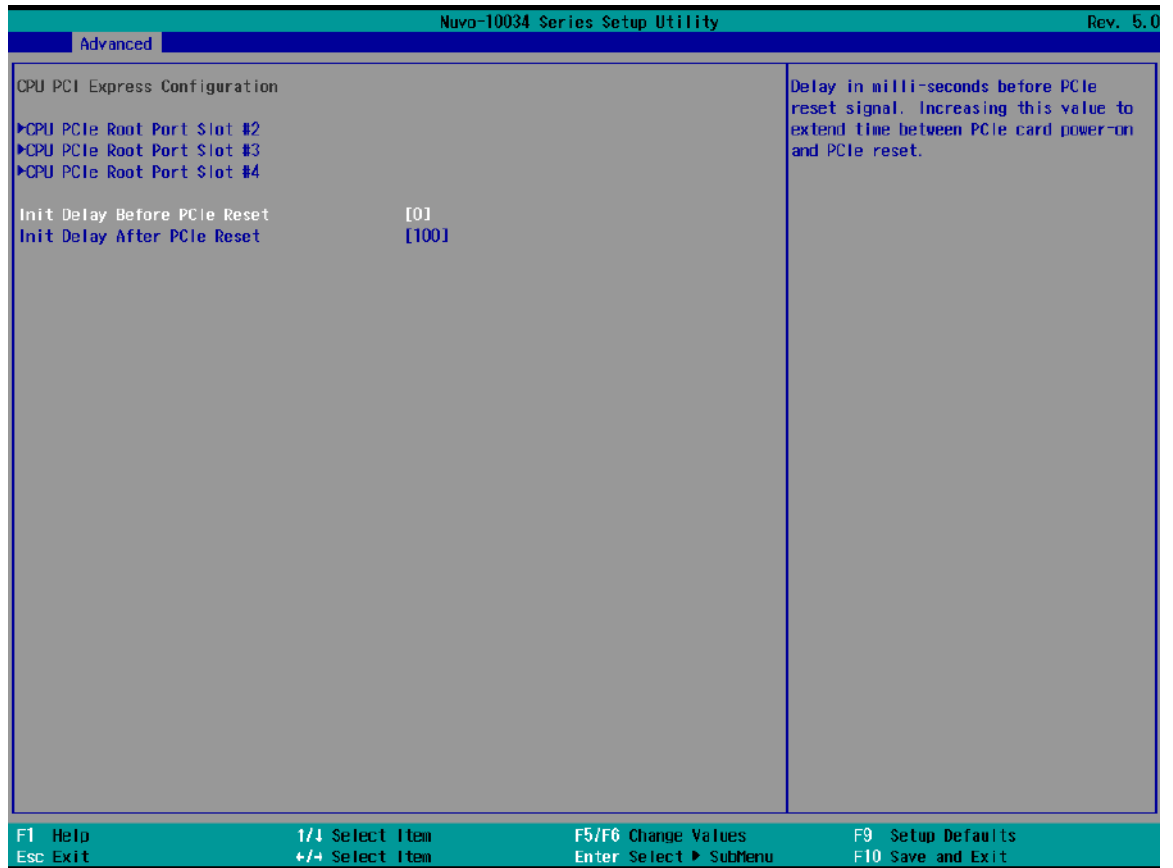

To set PEG delay in milliseconds:

1. When system boots up, press F2 to enter BIOS setup utility.
2. Go to **[Advanced] > [System Agent (SA) Configuration] > [CPU PCIe Express Configuration]** and press ENTER.
3. A small window appears and you may enter delay value before or after PCIe reset in ms.
4. When done, press F10 to "Exit Saving Changes"

4.1.4 Fan Control Configuration

The fan control configuration allows users to set the fan operation mode to auto or fixed speeds operation. The auto mode configuration also offers minimum temperature setting to trigger the fan and the maximum temperature setting before the fan operates at 100% rotation speed.

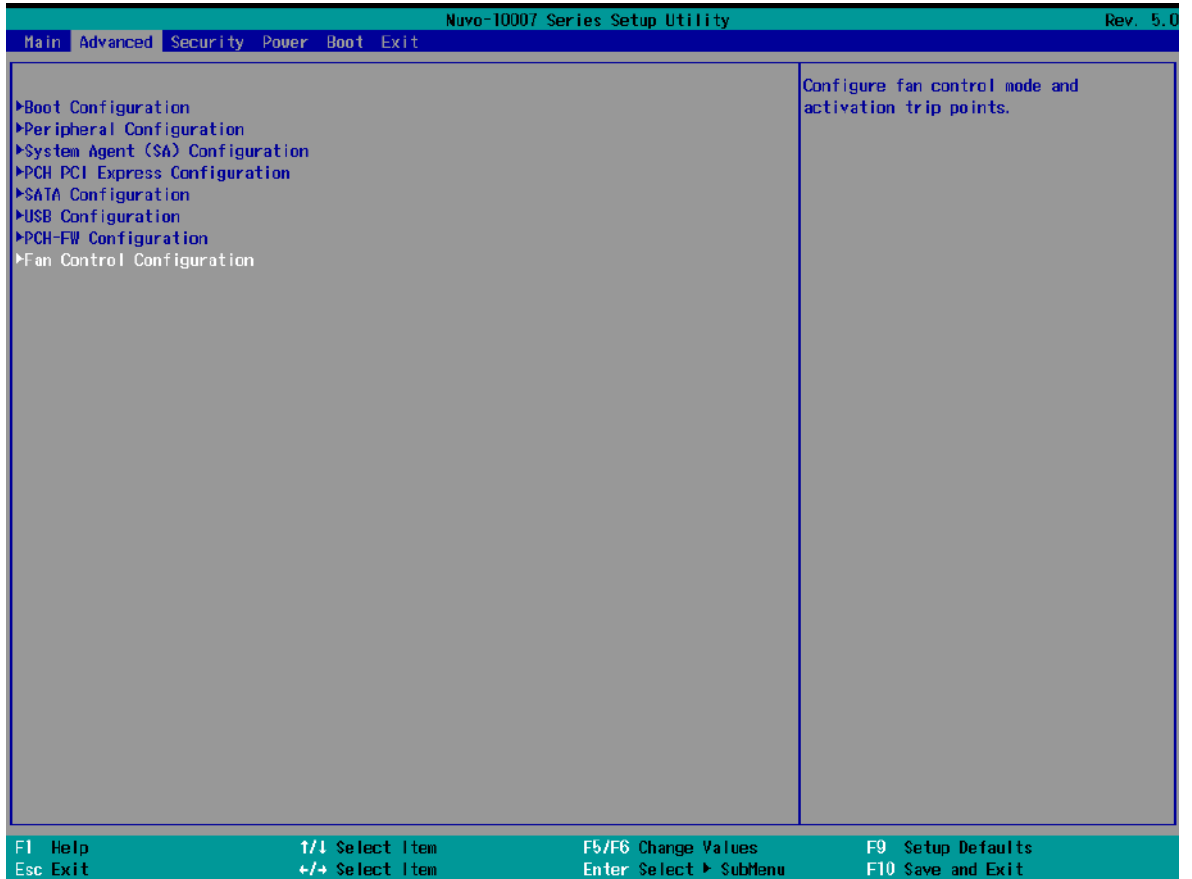

To set Fan Control Configuration to Auto mode:

1. When system boots up, press F2 to enter BIOS setup utility.
2. Go to **[Advanced]** > **[Fan Control Configuration]** and press ENTER.
3. To set auto fan control, highlight **[Fan Control Mode]** and press ENTER, highlight **[Auto]**
4. Use the up/ down arrow keys to highlight Fan Start Trip Point or Fan Max. Trip Point and press ENTER, a window appears and you may enter the temperature in degree Celsius.
 - **Fan Start Trip Point:** The minimum temperature which the fan being to operate
 - **Fan Max. Trip Point:** The maximum temperature where the fan begins to operate at 100% rotation speed

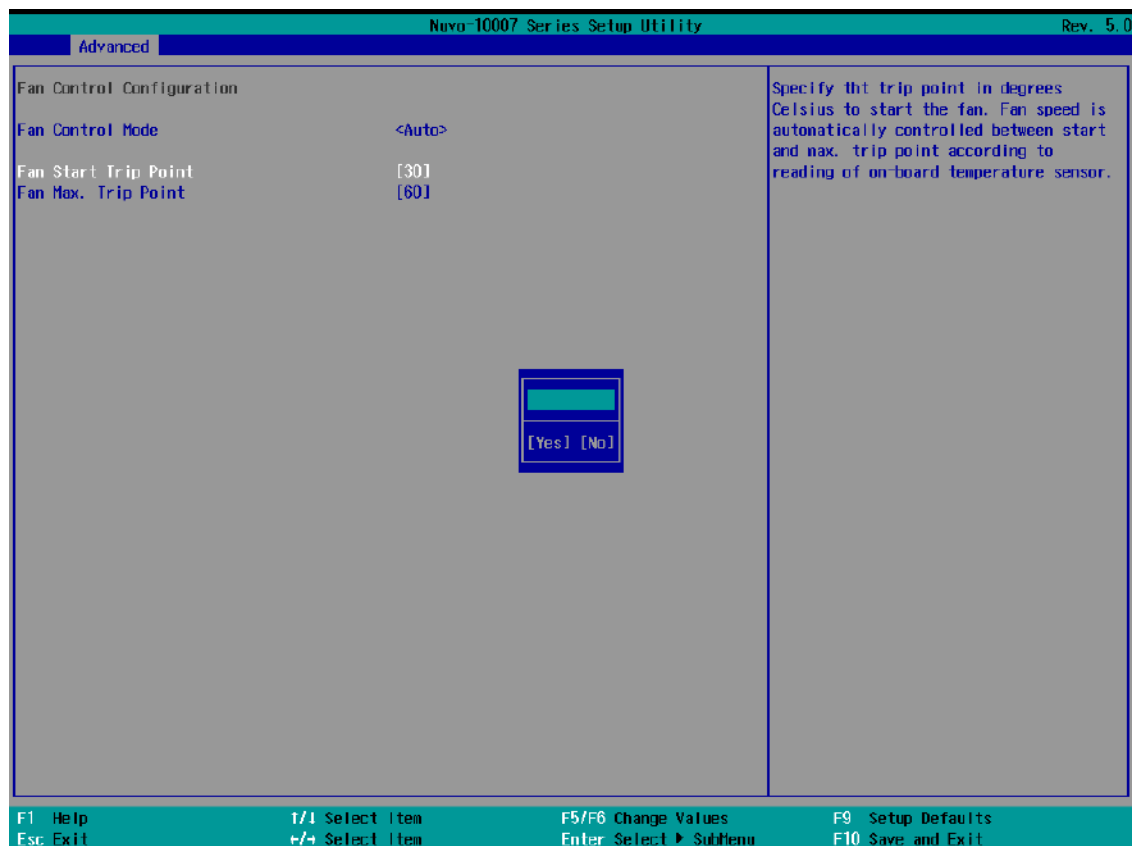

5. When done, press F10 to "Exit Saving Changes".

To set Fan Control Configuration to Fixed Speed mode:

1. When system boots up, press F2 to enter BIOS setup utility.
2. Go to **[Advanced]** > **[Fan Control Configuration]** and press ENTER.
3. To set auto fan control, highlight **[Fan Control Mode]** and press ENTER, highlight **[Fixed Speed]**.

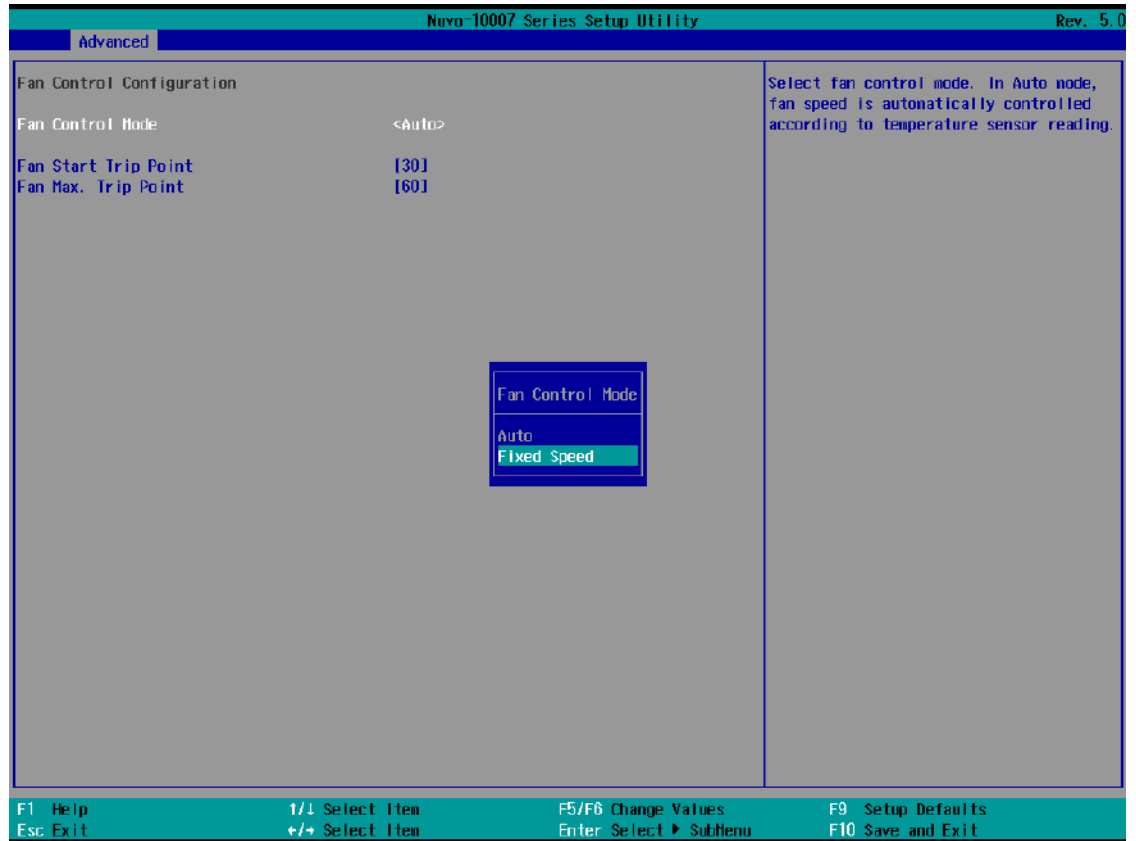

4. Highlight [**Fan Speed**] and press ENTER.
5. A window appears and you may use the up/ down arrow keys to select between 20~100% as your fixed fan rotation speed.

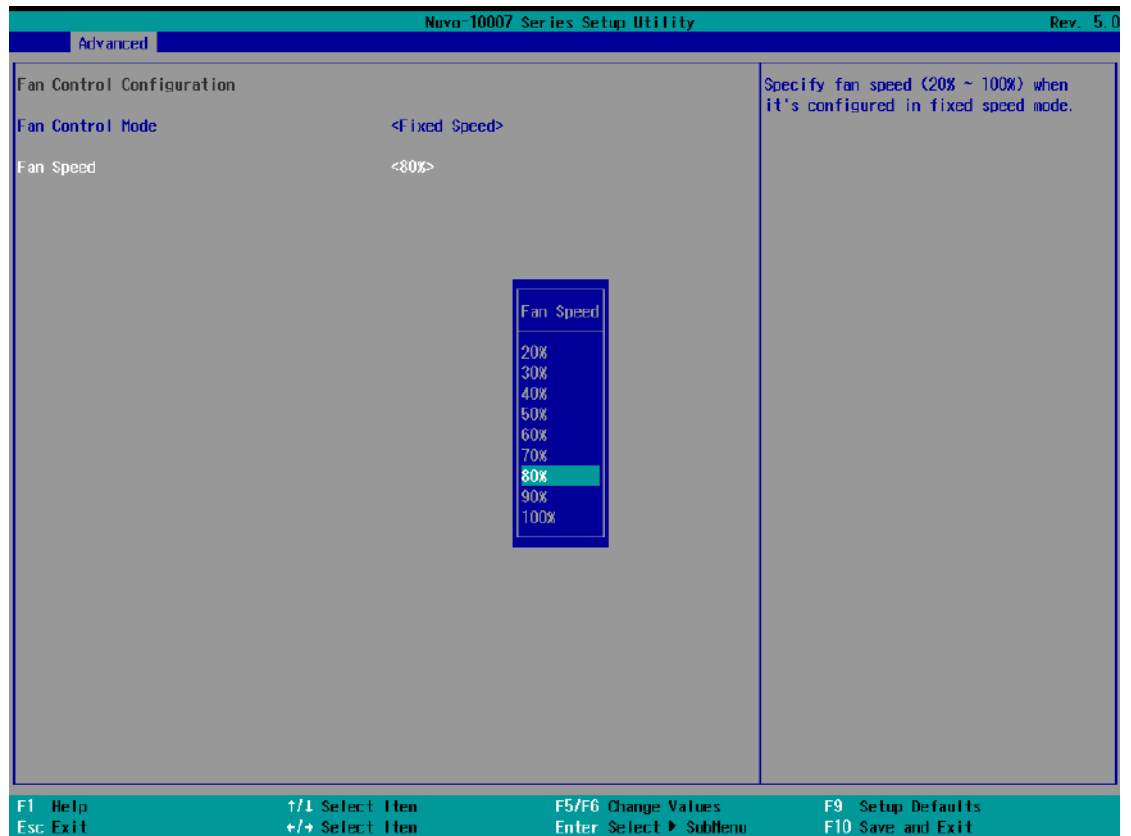

6. When done, press F10 to "Exit Saving Changes".

4.1.5 Power On After Power Failure Option

This option defines the behavior of System series when DC power is supplied.

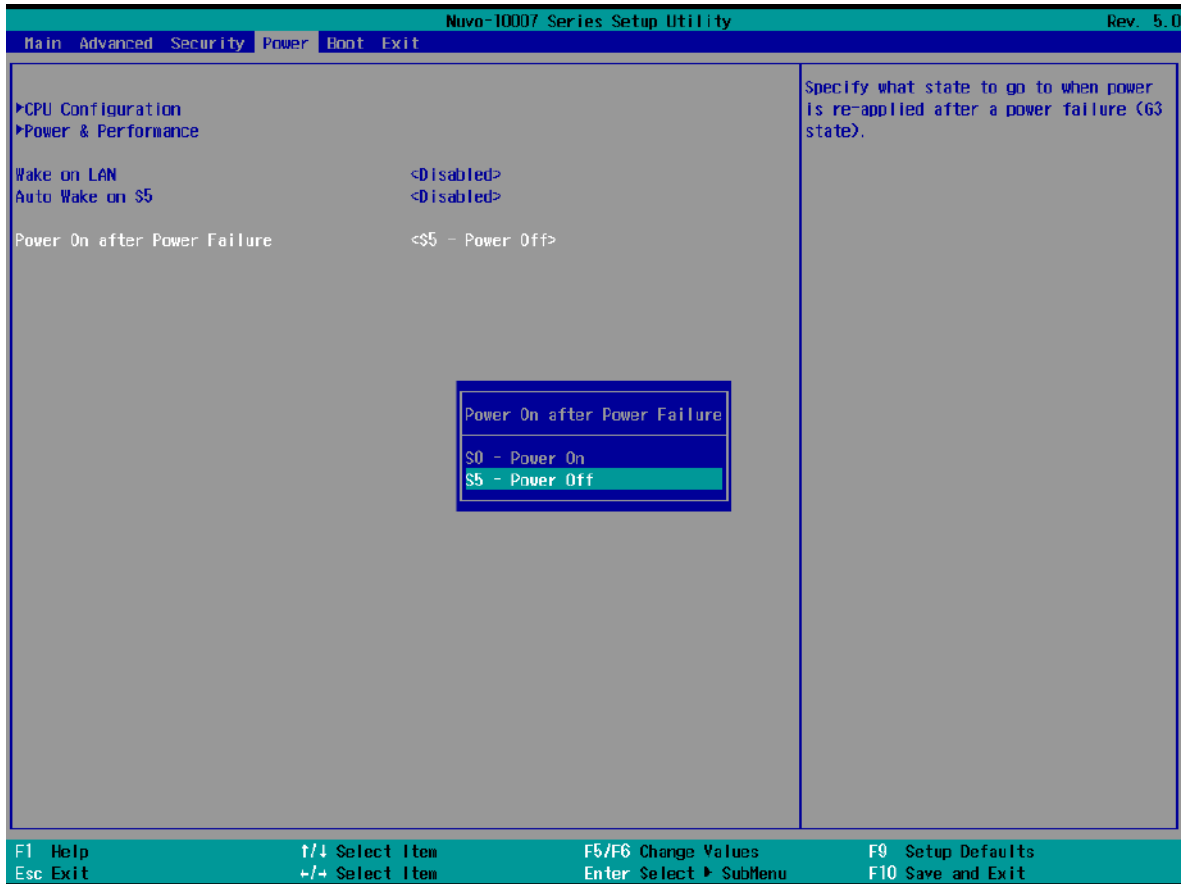

Value	Description
S0 – Power On	System is powered on when DC power is supplied.
S5 – Power Off	System is kept in off state when DC power is supplied.

To set “Power On after Power Failure” option:

1. When system boots up, press F2 to enter BIOS setup utility.
2. Go to **[Power] > [Power On after Power Failure]**.
3. Scroll down to highlight **[Power On after Power Failure]**, press ENTER to bring up setting options, S0 – Power On or S5 – Power Off, and press ENTER to select the setting.
4. Press F10 to “Exit Saving Changes”.

4.1.6 Power & Performance (CPU SKU Power Configuration)

The system supports Intel 14th/ 13th/ 12th Gen. hybrid power/ efficient core CPUs. A unique feature, “**SKU Power Config**” is implemented in BIOS to allow users to specify user-defined SKU power limit. Although the system is designed to have best thermal performance with CPUs of 35W TDP, you can install a 65W CPU and limit its SKU power (to 35W) to obtain more computing power. This feature gives you the flexibility of CPU selection and great balance between computing power and operating temperature range.

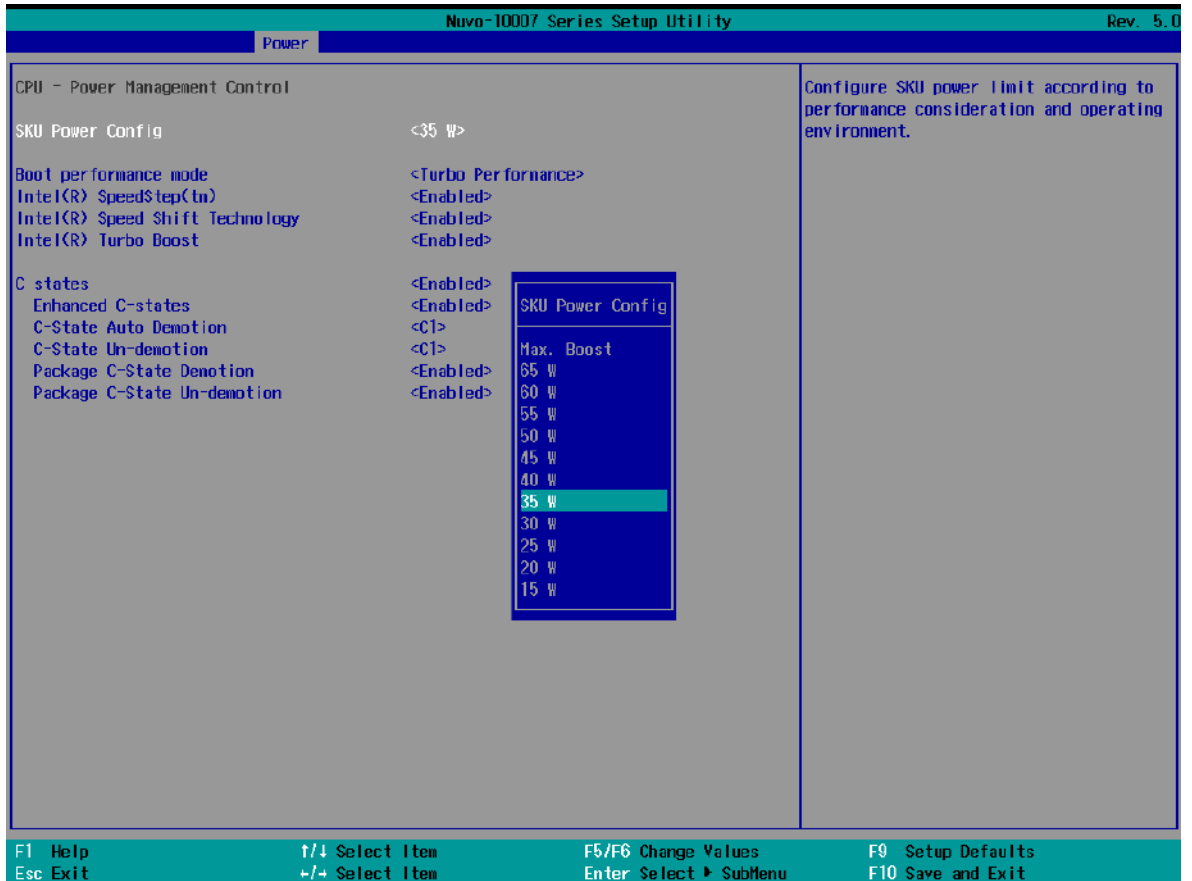

To configure the CPU SKU power limit:

1. When the system boots up, press F2 to enter BIOS setup utility.
2. Go to **[Power]** → **[Power & Performance]**.
3. Select a proper value of SKU power limit for **[SKU Power Config]** option.
4. Press F10 to "Exit Saving Changes".

4.1.7 Wake on LAN Option

Wake-on-LAN (WOL) is a mechanism which allows you to turn on your System series via Ethernet connection. To utilize Wake-on-LAN function, you have to enable this option first in BIOS settings. Please refer "[Powering On Using Wake-on-LAN](#)" to set up the system.



To enable/ disable “Wake on LAN” option:

1. When system boots up, press F2 to enter BIOS setup utility.
2. Go to **[Power]> [Wake on LAN]**.
3. Press ENTER to bring up setting options, scroll to the setting you desire and press ENTER to set.
4. Press F10 to “Exit Saving Changes.”

4.1.8 Boot Menu

The Boot menu in BIOS allows you to specify the system’s boot characteristics by setting bootable device components (boot media) and method. Or, you may press F12 upon system start up and select a device you wish boot from.

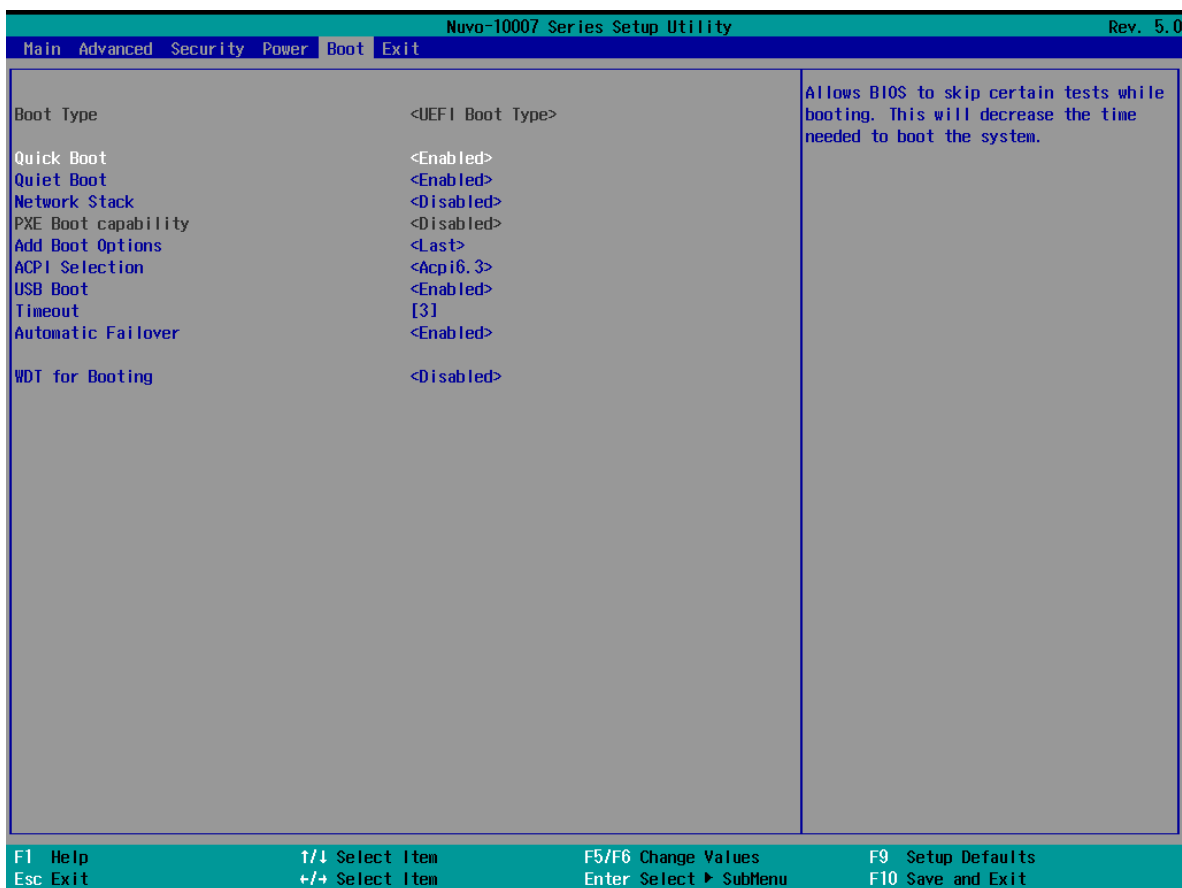

Value	Option	Description
Quick Boot	Enabled	The system starts up faster because BIOS skips various hardware function tests
	Disabled	The system starts up slower because BIOS goes through various hardware functions tests
Network Stack	Enabled	The system is available for network access using UEFI.
	Disabled	The system is not available for network access using UEFI.
PXE Boot capability	Disabled	Only UEFI Network Stack is supported: Preboot eXecution Environment (PXE) is not supported
	Enabled	By enabling the PXE boot, one can choose to boot via I219 Only/ I210 Only or All NICs .
Add Boot Options	First	Newly detected boot media are placed at the

		top of the boot order.
	Last	Newly detected boot media are placed at the bottom of the boot order.
ACPI Selection	1.0B/ 3.0/ 4.0/ 5.0/ 6.0	Advanced Configuration and Power Interface allows the operating system to control system power management
USB Boot	Enabled	Allow boot from bootable USB devices.
	Disabled	Does not allow boot from bootable USB devices
EFI Device First	Enabled	Set to boot bootable EFI media first.
	Disabled	Will not boot bootable EFI media first.
Timeout	1, 2, 3, etc (in seconds)	Boot delay time in seconds to give the user time to activate the hotkey to access the BIOS
WDT for booting	Disabled, 1, 3, 5, 10 (minutes)	WDT ensures a successful system boot by specifying a timeout value

4.1.9 Add Boot Options

The “Add Boot Options” allow you to determine whether a newly added device (eg. USB flash disk) is to boot as the first device to boot or the last in the boot sequence.

To set the newly-installed boot device as the first or last boot device:

1. Press **F2** when the system boots up to enter the BIOS setup utility.
2. Go to **[Boot] > [Add Boot Options]** menu.
3. Select **[First]** or **[Last]** for your newly-added boot device and press ENTER.

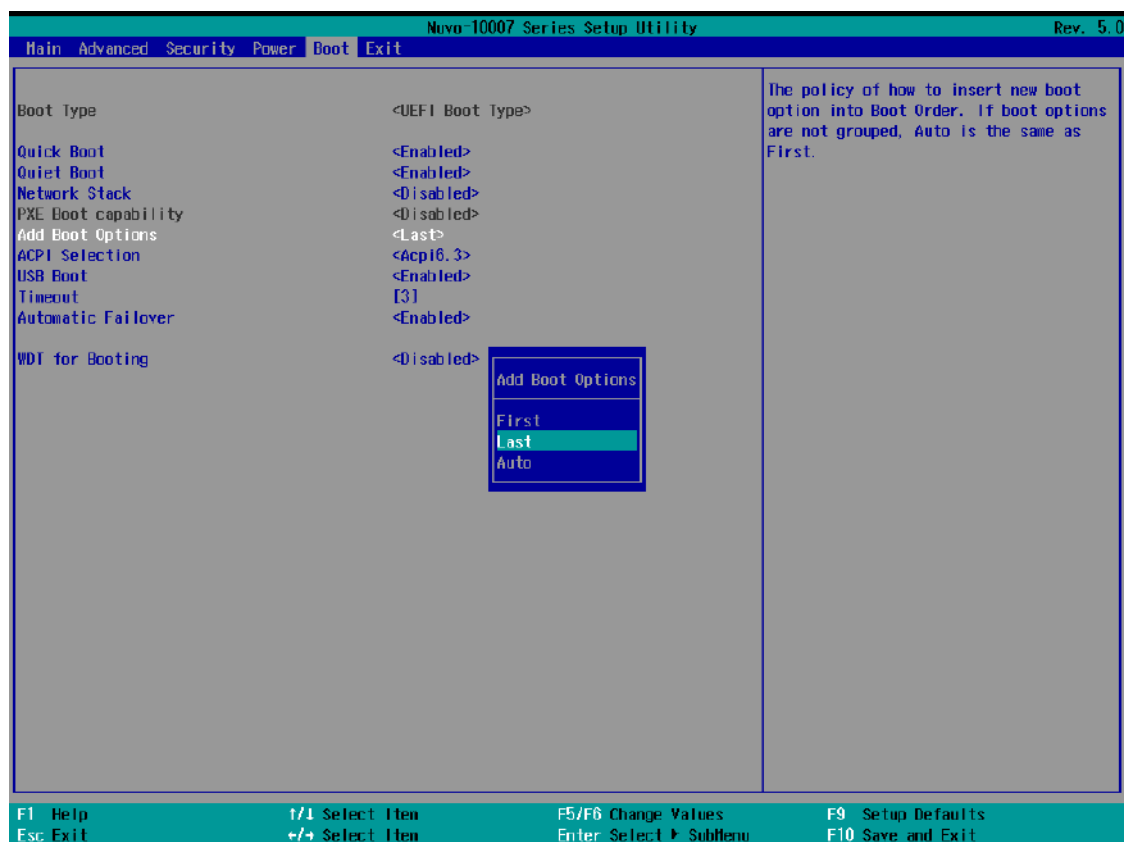

4. Once set, press **F10** to save setting and exit.

4.1.10 Watchdog Timer for Booting

The watchdog timer secures the boot process by means of a timer. Once the timer expires, a reset command is issued to initiate another booting process. There are two options in BIOS menu, “*Automatically after POST*” and “*Manually after Entering OS*”. When “*Automatically after POST*” is selected, the BIOS automatically stops the watchdog timer after POST (Power-On Self Test) OK. When “*Manually after Entering OS*” is selected, the user must stop the watchdog timer once booted into the OS. This guarantees the system can always boot into the OS, otherwise another booting process will be initiated. For information about programming watchdog timer, please refer to [Watchdog Timer & Isolated DIO](#).



To set the watchdog timer for boot in BIOS:

1. When system boots up, press F2 to enter BIOS setup utility.
2. Go to **[Boot]** menu.
3. Disable or select timeout value for **[WDT for Booting]** option.
4. Once you give a timeout value, the **[WDT Stop Option]** option appears. You can select “*Automatically after POST*” or “*Manually after Entering OS*”.
5. Press F10 to “Exit Saving Changes”.

4.2 AMT Configuration

Intel® AMT (Active Management Technology) is a hardware-based technology for remotely managing target PCs via Ethernet connection. The system supports AMT function via its Ethernet port implemented with Intel I219-LM. Prior to using the AMT function to remotely control the system, you need to configure AMT password and network settings.

1. Connect an Ethernet cable to the I219-LM Ethernet port.

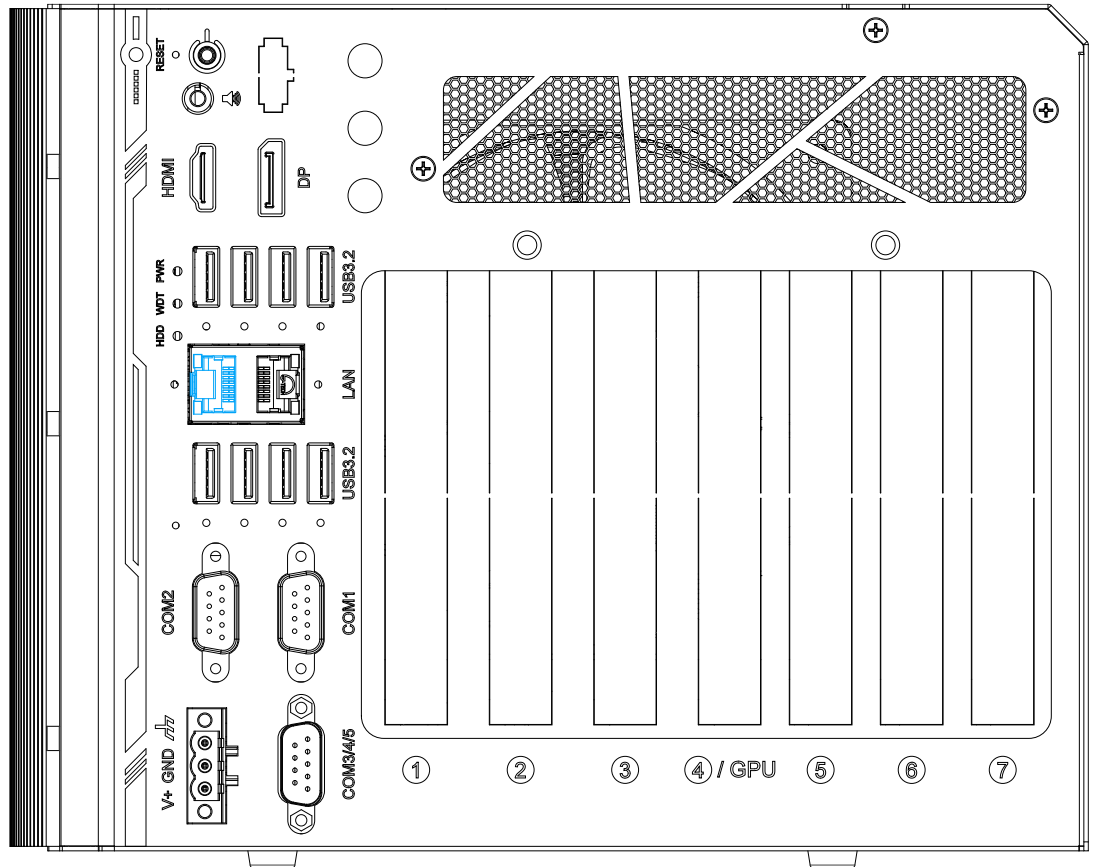

- When the system boots up, press F10 to enter the MEBx configuration menu.

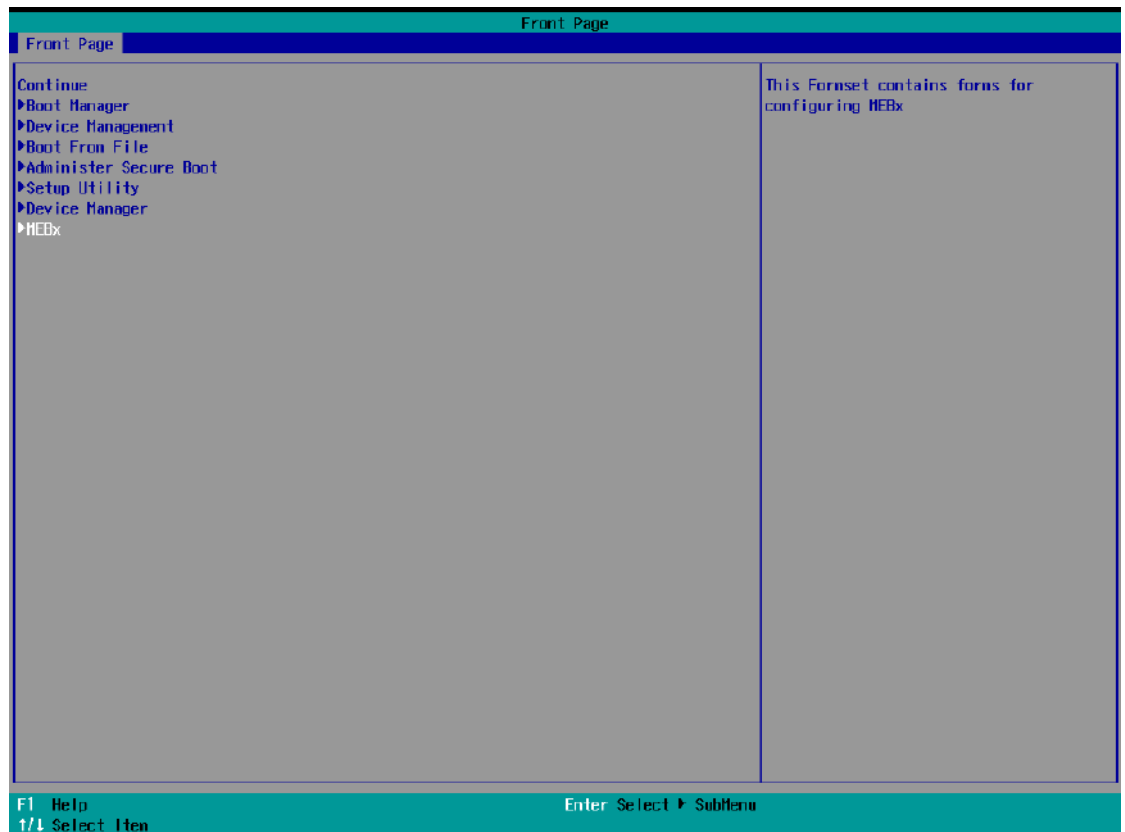

- When entering MEBx for the first time, it will ask for the default (old) password. Please type "admin" and press ENTER.



- The system will then request that you enter a new password. The new password must consist of at least one 7-bit ASCII non alpha-numeric character, above 32 (eg,!, @, \$) and 8 to 32 characters long. Note that under score "_" is considered an alpha-numeric character.



5. After typing your new password, it will bring you to the MEBx settings page. For more MEBx configuration details, please refer to [Intel® MEBX User Guide](#).



4.3 RAID Configuration

To set up a RAID 0 or 1 volume, you need to have at least two hard drives or SSDs installed. The system supports RAID configurations in RAID 0 (striping) or RAID 1 (mirror) mode. Users can select the configuration that best suit their needs with RAID 0 (striping) mode offering better hard drive read/ write performances while RAID 1 (mirror) offers better data security.



WARNING

Please back up the hard drive data before you create or modify RAID volume(s) as the process may cause irreversible data deletion. When creating a RAID volume, it is also recommended to use hard drives from the same batch (same brand, model, capacity, rpm rate, etc.) to avoid performance or capacity allocation issues.

4.3.1 Enabling Volume Management Device (VMD) for RAID Volume Setup

1. When system boots up, press F2 to enter BIOS setup utility.
2. Go to **[Advanced]** > **[System Agent (SA) Configuration]** > **[VMD setup menu]**, and press ENTER.

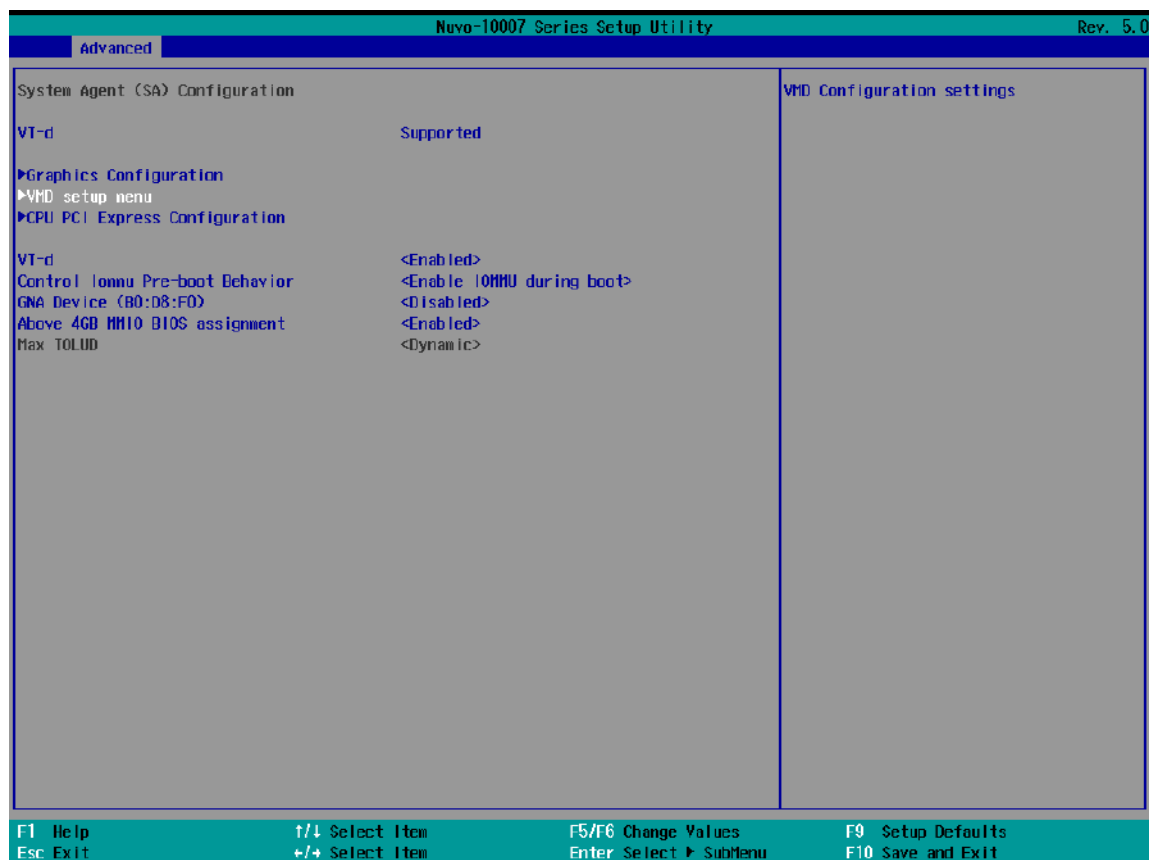

3. Select **[Enable VMD controller]** and press ENTER, highlight **[Enabled]** and press ENTER.

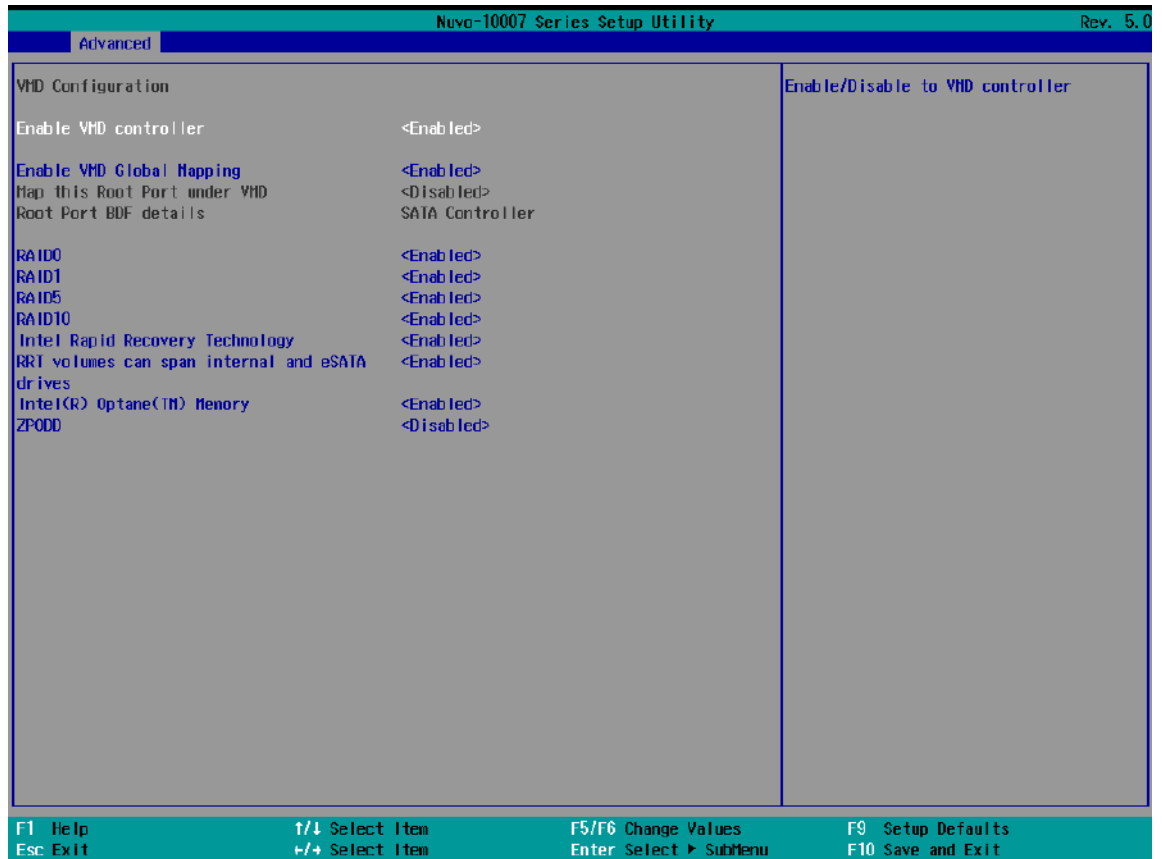

4. Press F10 to “Exit Saving Changes” and reboot the system.
5. When the system reboots, press **[F3]** to enter the Device Manager configuration utility.

4.3.2 RAID Volume Setup

1. Once you've press F3 upon system boot up and you are in the Device Manager configuration utility, select **[Intel® Rapid Storage Technology]** and press ENTER.



2. The following screen shows Non-RAID physical disks and the option “**Create RAID Volume**”. Highlight “**Create RAID Volume**” and press ENTER to begin creating your RAID volume.

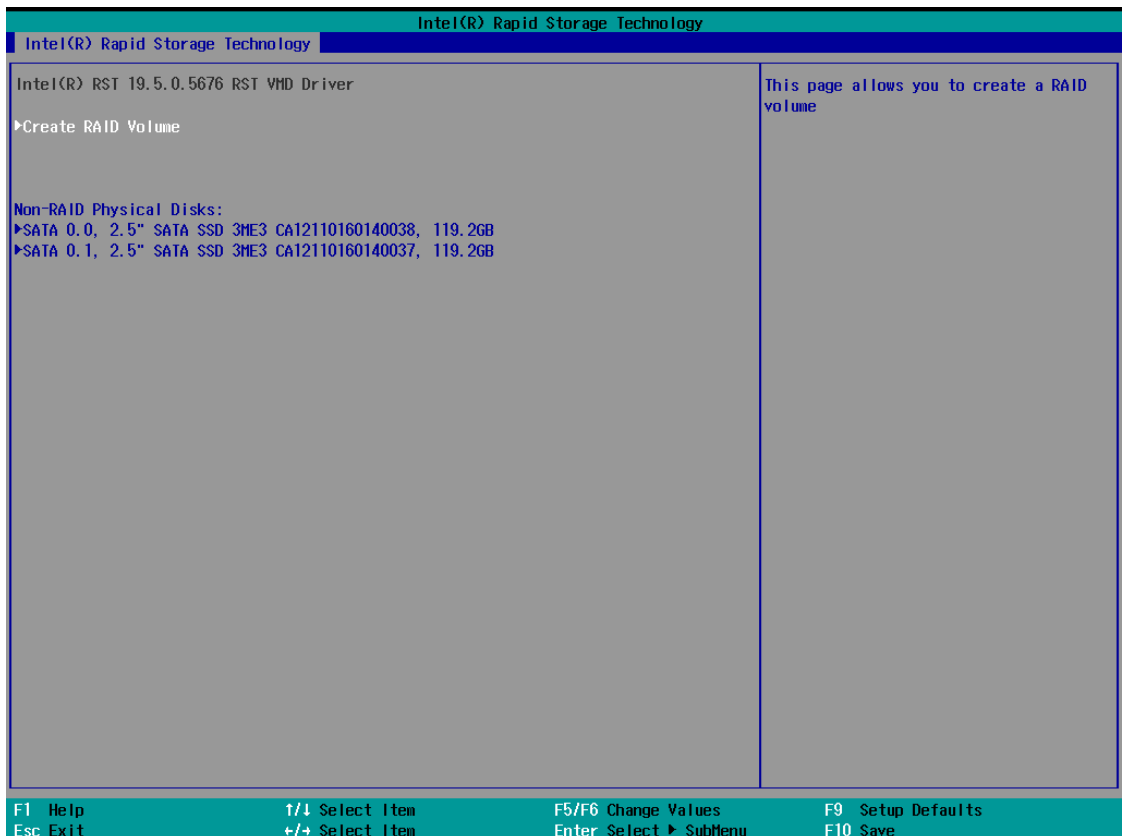

- The Name option allows you to name your RAID volume. Press ENTER when ready to go to the next option.

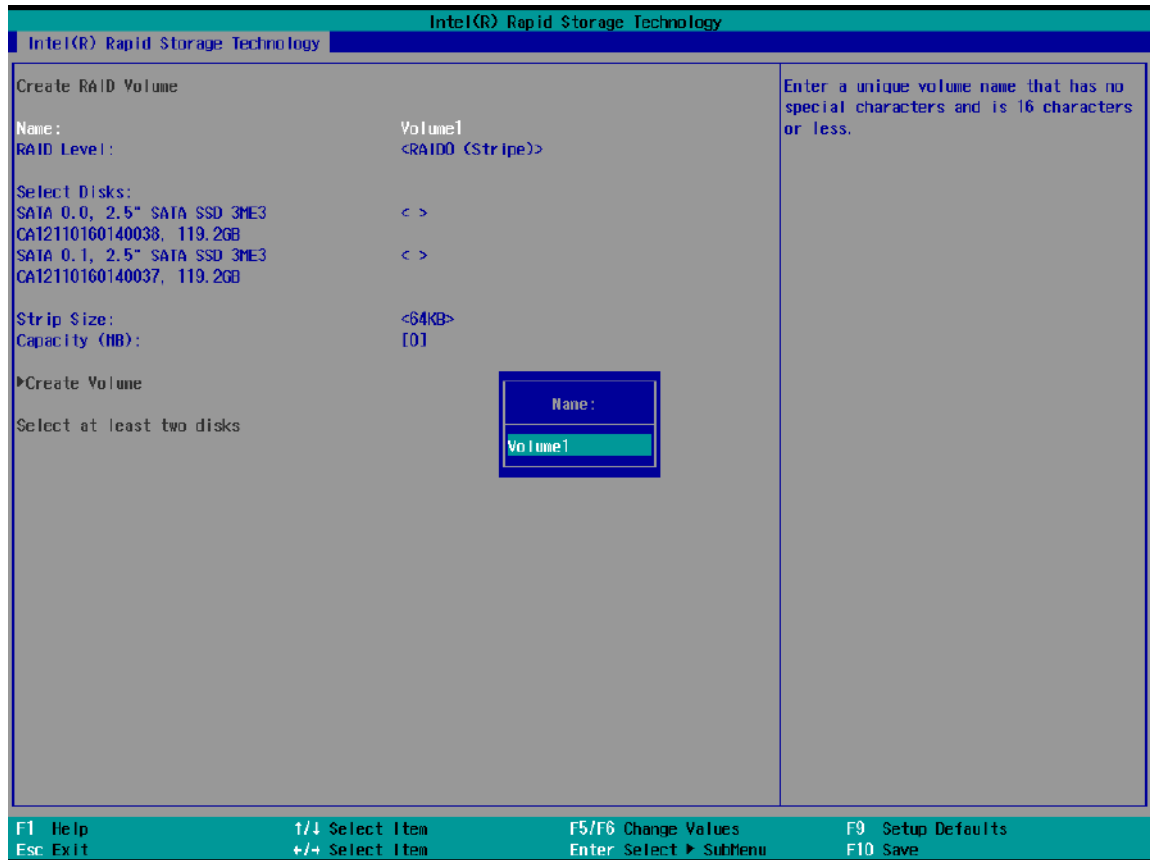

- The RAID Level option allows you to select RAID-0 (striping) or RAID-1 (mirror) for your RAID volume. Press ENTER when ready.

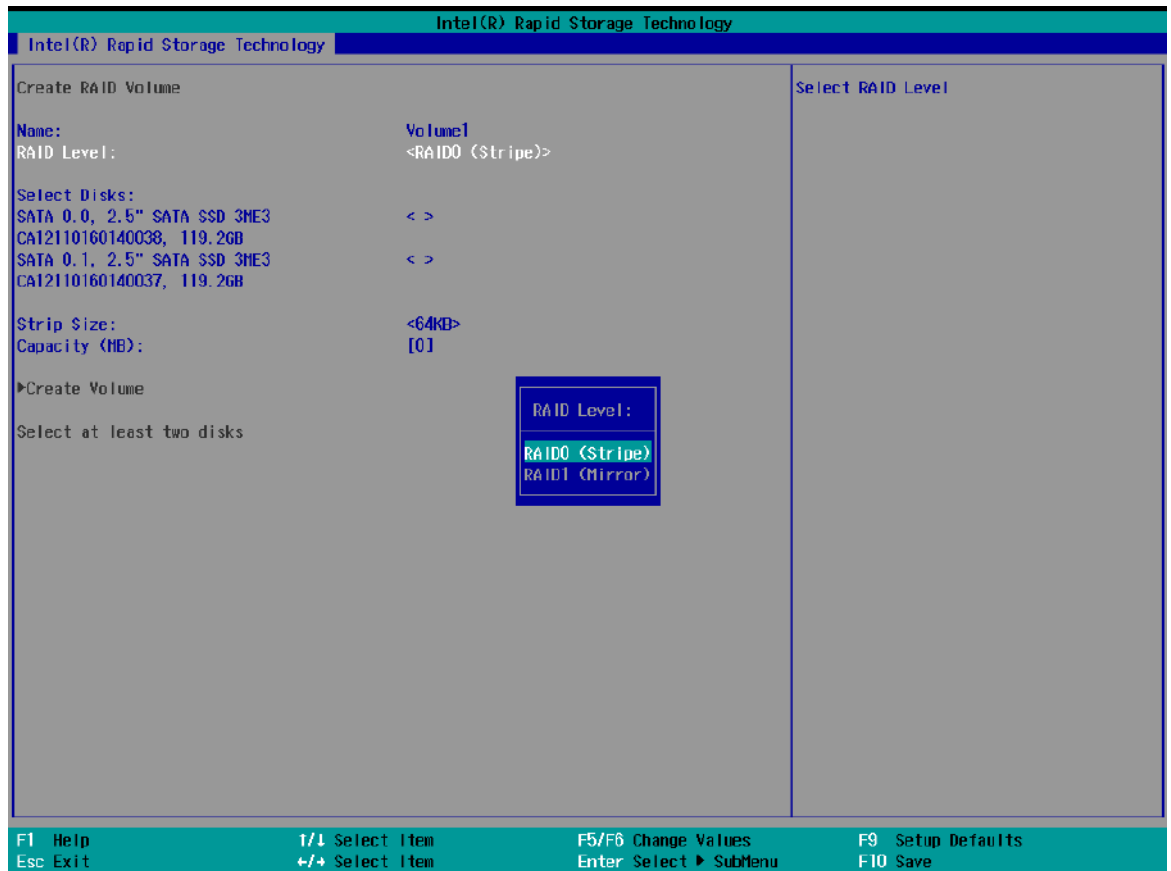

- The Select Disks option allows you to select disk drives for your RAID volume. Highlight a drive and press ENTER, use up/ down arrow keys to highlight "x" and press ENTER to confirm the selection. A minimum of two disk drives must be selected for RAID-0 or RAID-1 configuration. Press ENTER when ready.

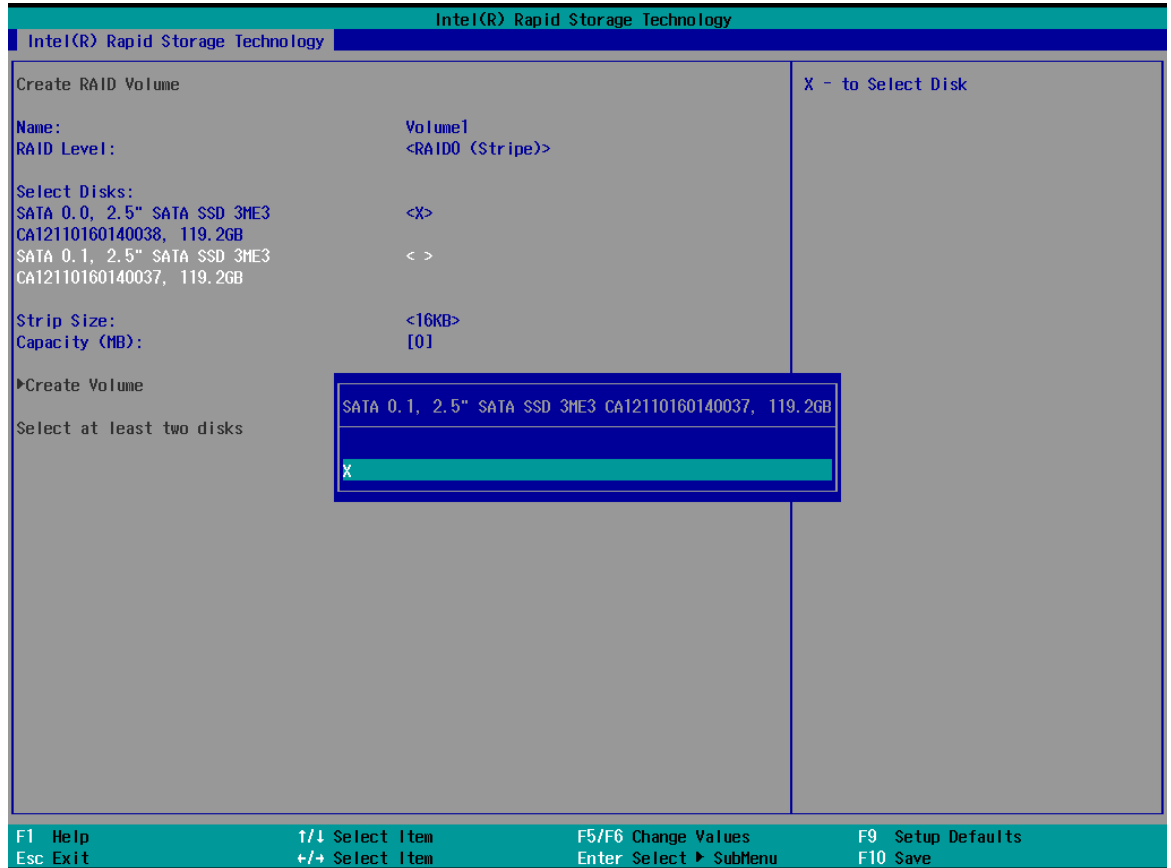

6. The Stripe Size option allows you to configure the stripe size of your RAID volume. Available stripe sizes are 4KB, 8KB, 16KB, 32KB, 64KB, 128KB, use the up and down arrow keys to highlight and press ENTER to confirm the stripe size selection.

*RAID1(Mirror) does not offer Stripe Size options.

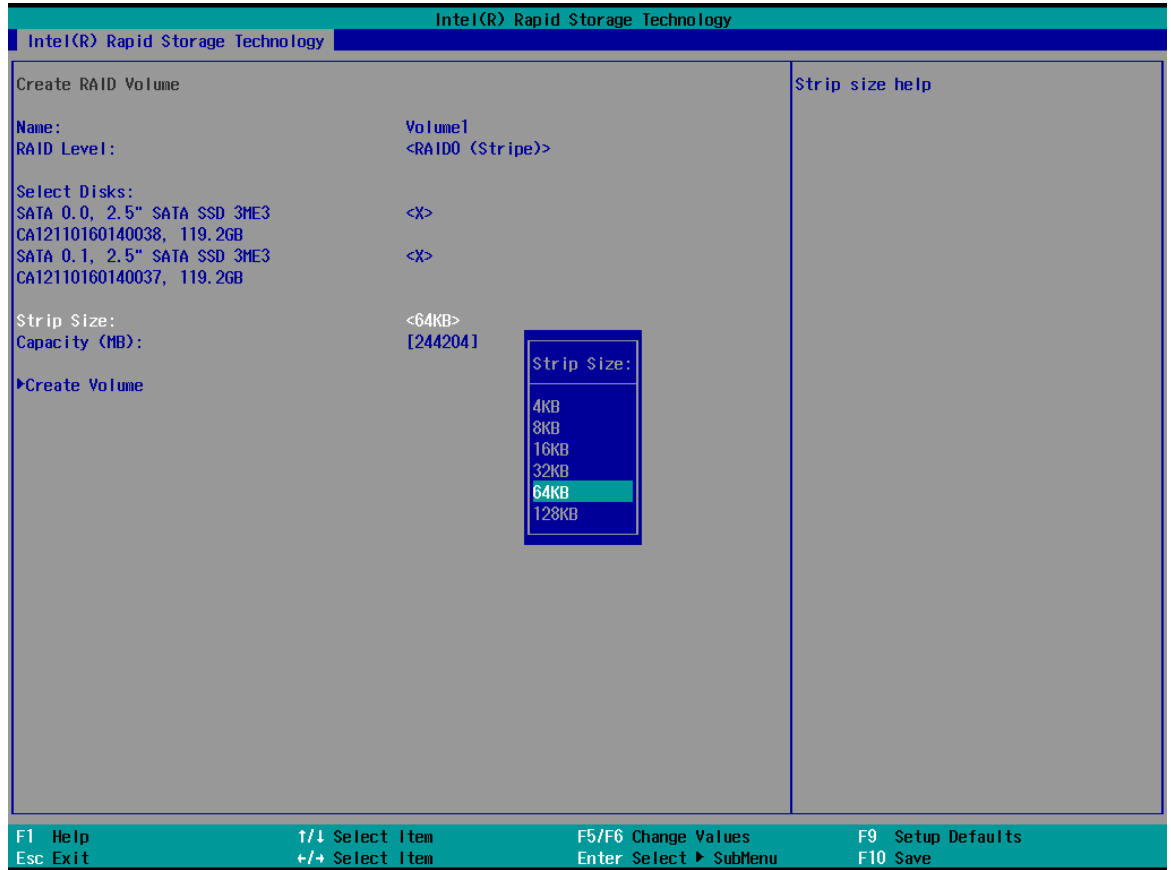

- The Capacity (MB) option allows you to configure the storage capacity of your RAID volume. By default, the full storage capacity will be applied. Once you have entered a capacity, press ENTER to confirm.



- The Create Volume option is the final step in the volume creation process. Highlight “**Create Volume**” and press ENTER to begin creating your RAID volume base on the settings you just configured.

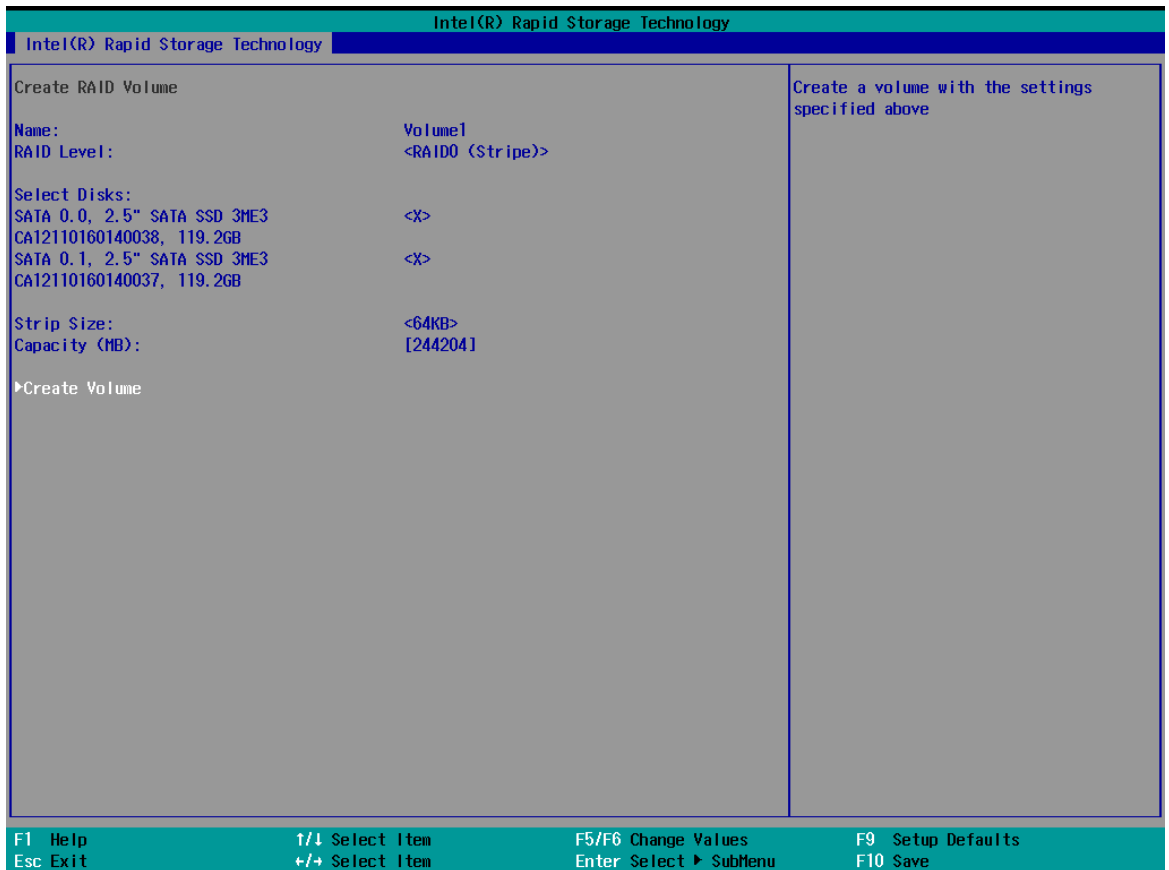

- A summary and status of the RAID volume will be shown when the RAID volume is successfully created.

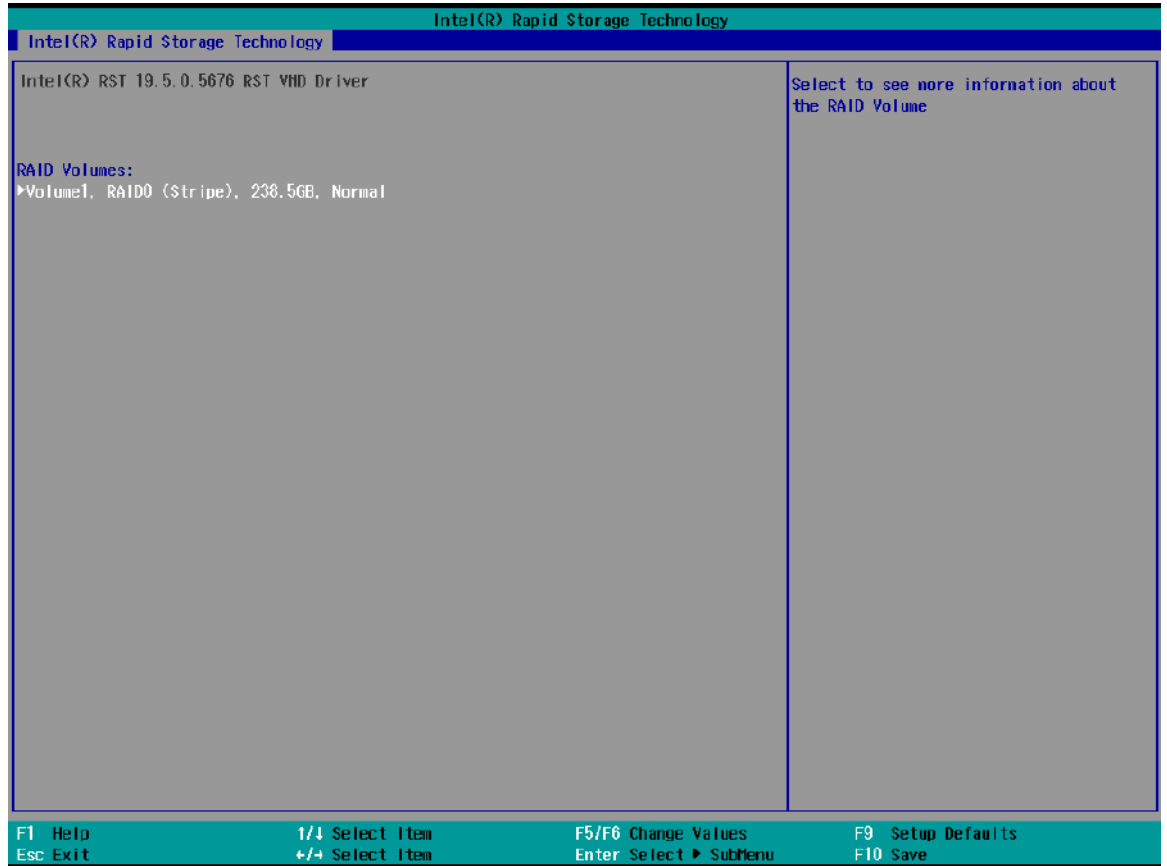

- Press F10 to save and Esc to exit the Intel® Rapid Storage Technology configuration page.

 **NOTE**

The above process was to create a RAID-0 volume. If you wish to create a RAID-1 volume, please perform RAID Volume Setup process and select RAID-1 (Mirror) during step 4.

4.3.3 Loading RAID Driver for Windows Installation

To install Windows on the RAID volume you created, please refer to the following procedure:

1. Please prepare a bootable Windows installation USB drive with the zip file "[f6vmdflpy-x64](#)". Download and unzip the driver files, copy the driver files onto the Windows installation USB drive.
2. Connect the Windows installation USB drive into one of the USB connections on the system.
3. Windows installation process should automatically begin (if not, please make sure the boot device in BIOS is set properly).
4. Select the "Load Driver" icon.

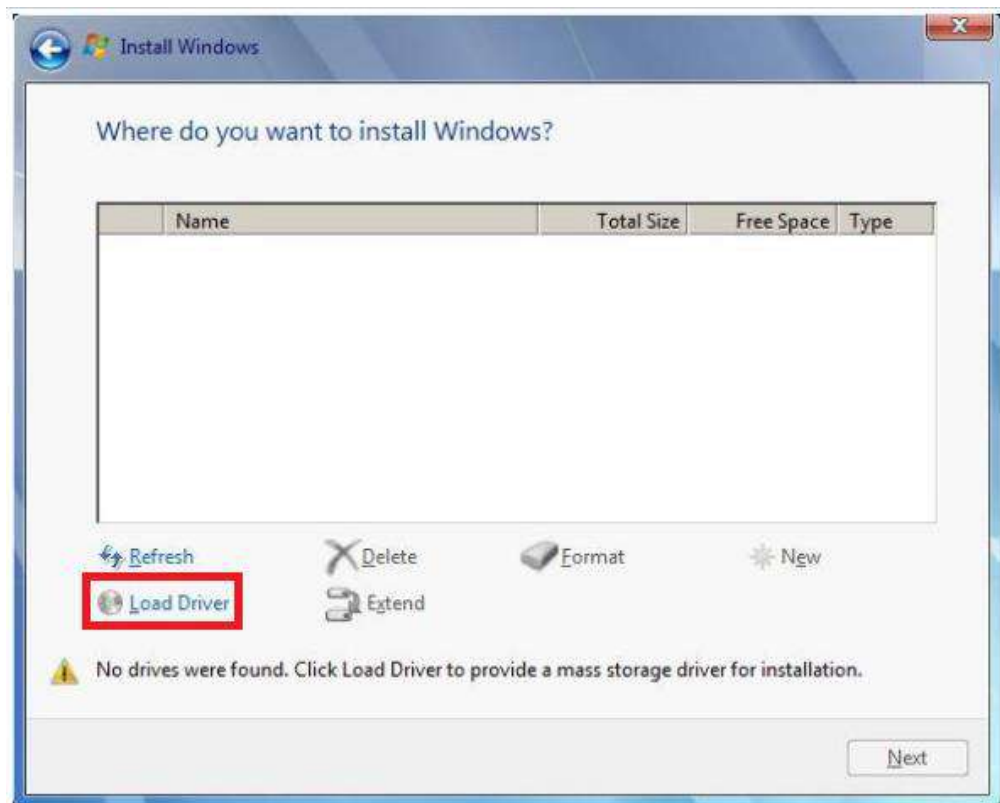

5. In the pop-up Window, select “Browse”, go to the directory where you saved the unzipped drivers “f6vmdflpy-x64”, and click OK.

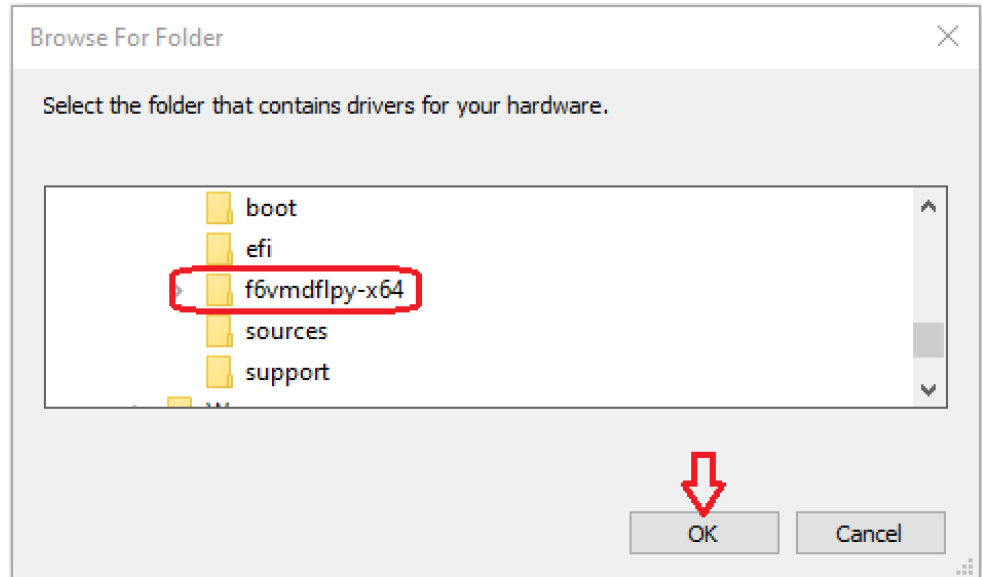
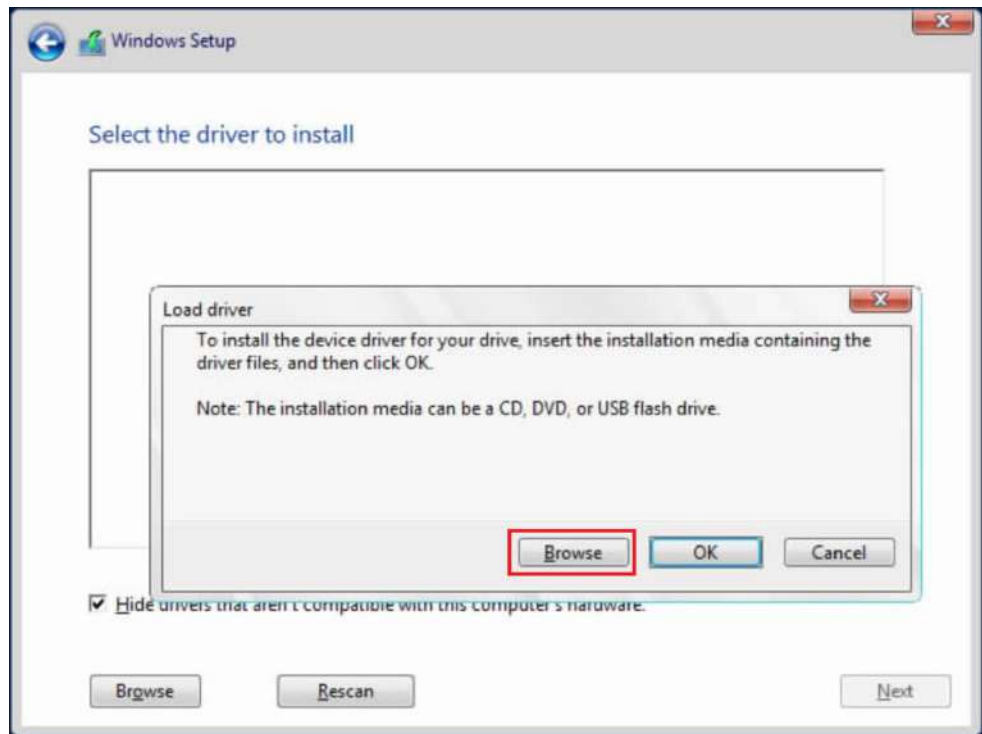

6. Select the driver "Intel RST VMD Controller 467F" and click on Next.

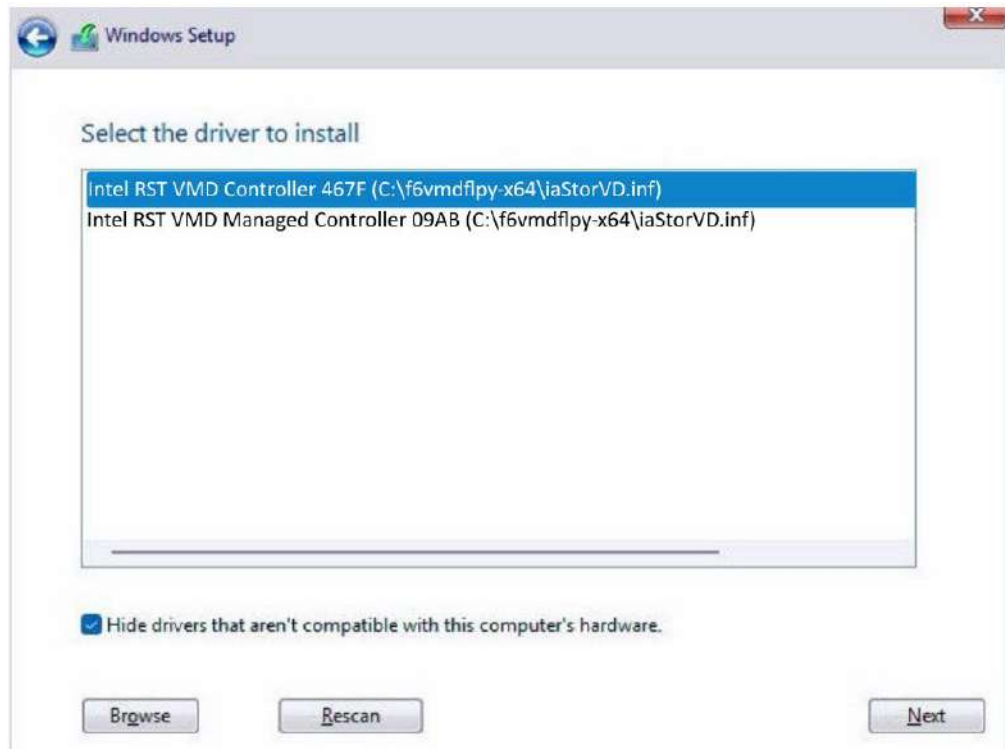

7. The previous created RAID volume shall appear as unallocated space.

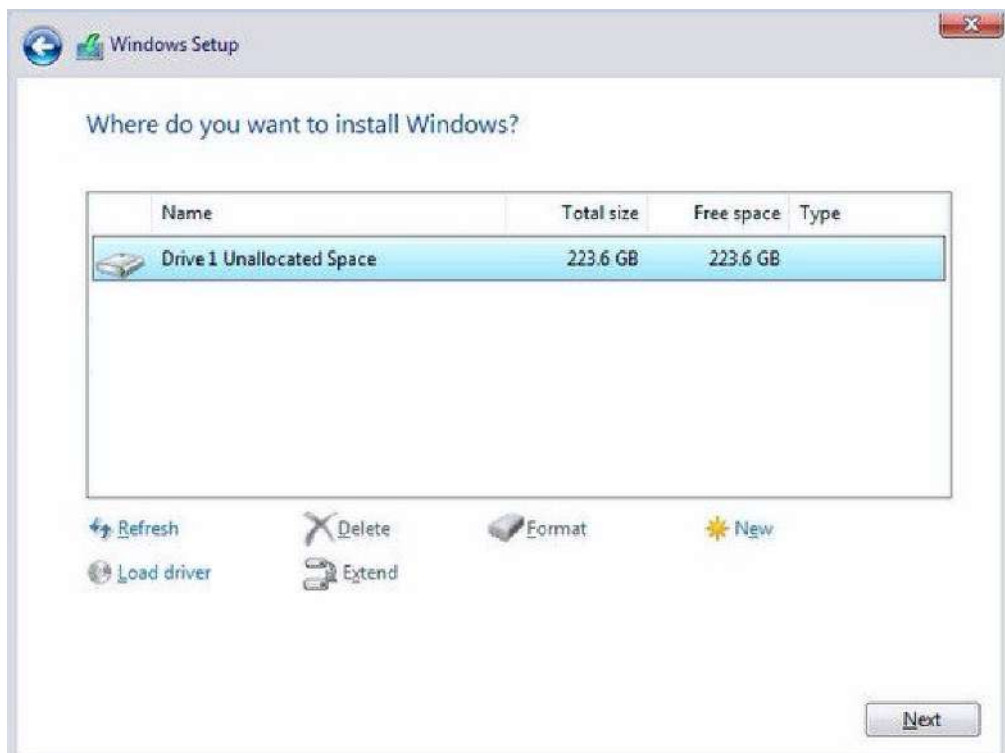

From here, follow the standard Windows installation procedures.

5 OS Support and Driver Installation

5.1 Operating System Compatibility

The system supports most operating system developed for Intel® x86 architecture. The following list contains the operating systems which have been tested by Neosys Technology.

- Microsoft Windows 10 LTSC 2021 (x64)
- Microsoft Windows 11 IoT Enterprise 22H2 64-bit
- Ubuntu 20.04.5 LTS, 22.04 LTS, 22.04.1 LTS or other distribution with kernel version \geq 5.15 */**



NOTE

** For Linux system, user may need to manually compile and install the driver for Intel graphics or I225/ I226 GbE controller if the driver is not embedded in kernel. You can visit Intel website for further information.*

*** For distributions, graphics driver and RAID function may not be completely implemented in its kernel. You may encounter restrictions when using these features, such as triple independent display and RAID. For optimum operation, it is the users' responsibility to manually check for new drivers and upgrades!*

Neosys may remove or update operating system compatibility without prior notice. Please contact us if your operating system of choice is not on the list.

5.2 Driver Installation

The system drivers are available online, please click on this [link](#) to download the drivers.

5.3 Driver Installation for Watchdog Timer Control

Neosys provides a driver package which contain function APIs for Watchdog Timer control function. You should install the driver package (WDT_DIO_Setup.exe) in prior to use these functions. Please note that you must install WDT_DIO_Setup_v2.3.1.9 or later versions.

Please refer to this [link](#) to download WDT_DIO.

Appendix A Using WDT & DIO

The watchdog timer (WDT) function to ensure reliable system operation. The WDT is a hardware mechanism to reset the system if the watchdog timer is expired. Users can start the WDT and keeping resetting the timer to make sure the system or program is running. Otherwise, the system shall be reset.

In this section, we'll illustrate how to use the function library provided by Neosys to program the WDT functions. Currently, WDT driver library supports Windows 10 x64 platform. For other OS support, please contact Neosys Technology for further information.

Installing WDT_DIO Library

The WDT_DIO function library is delivered in the form of a setup package named **WDT_DIO_Setup.exe**. In prior to program WDT, you should execute the setup program and install the WDT library. Please use the following WDT_DIO_Setup packages according to your operating systems and application.

- For Windows 10 64-bit OS with 64-bit application (x64 mode), please install WDT_DIO_Setup_v2.3.1.9 (x64).exe or later version.

WDT and DIO Library Installation

To setup WDT & DIO Library, please follow instructions below.

1. Execute **WDT_DIO_Setup.exe**. and the following dialog appears.

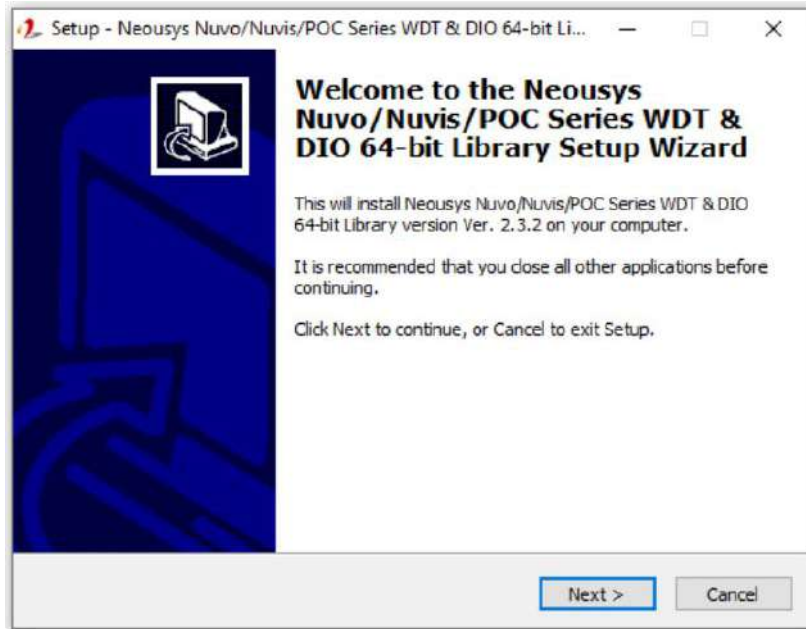

2. Click "Next >" and specify the directory of installing related files. The default directory is *C:\Neosys\WDT_DIO*.

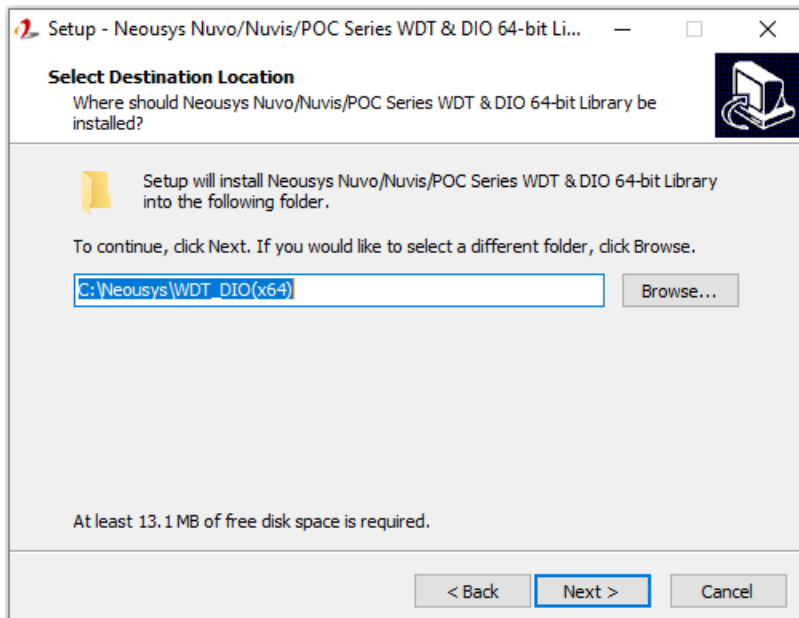

3. Once the installation has finished, a dialog will appear to prompt you to reboot the system. The WDT & DIO library will take effect after the system has rebooted.

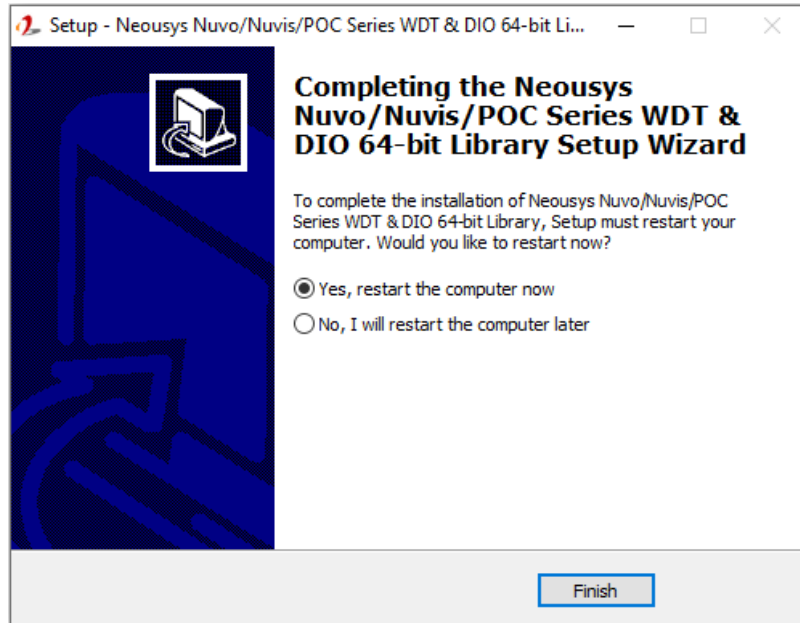

4. When programming your WDT or DIO program, the related files are located in

Header File:	\Include
Library File:	\Lib
Function Reference:	\Manual
Sample Code:	\Sample\WDT_Demo (Demo for Watchdog Timer)

WDT Functions

InitWDT

Syntax	BOOL InitWDT(void);
---------------	---------------------

Description:	Initialize the WDT function. You should always invoke InitWDT() before set or start watchdog timer.
Parameter	None
Return Value	TRUE: Successfully initialized FALSE: Failed to initialize
Usage	BOOL bRet = InitWDT()

SetWDT

Syntax	BOOL SetWDT(WORD tick, BYTE unit);
Description	Set timeout value and unit for watchdog timer. When InitWDT() is invoked, a default timeout value of 255 seconds is assigned.
Parameter	<i>tick</i> WORD value (1 ~ 65535) to indicate timeout ticks. <i>unit</i> BYTE value (0 or 1) to indicate unit of timeout ticks. 0 : unit is minute 1 : unit is second
Return Value	If value of unit is correct (0 or 1), this function returns TRUE, otherwise FALSE.
Usage	WORD tick=255; BYTE unit=1; //unit is second. BOOL bRet = SetWDT(tick, unit); //timeout value is 255 seconds

StartWDT

Syntax	BOOL StartWDT(void);
Description	Starts WDT countdown. Once started, the WDT LED indicator will begin blinking. If ResetWDT() or StopWDT is not invoked before WDT countdowns to 0, the WDT expires and the system resets.
Parameter	None
Return Value	If the timeout value is given in correct format (WDT started), this function returns TRUE, otherwise FALSE
Usage	BOOL bRet = StartWDT()

ResetWDT

Syntax	BOOL ResetWDT(void);
Description	Reset the timeout value to the value given by SetWDT(). If ResetWDT() or StopWDT is not invoked before WDT countdowns to 0, the WDT expires and the system resets.
Parameter	None
Return Value	Always returns TRUE
Usage	BOOL bRet = ResetWDT()

StopWDT

Syntax	BOOL StopWDT(void);
Description	Stops the countdown of WDT. When WDT has stopped, the WDT LED indicator stops blinking.
Parameter	None
Return Value	Always returns TRUE
Usage	BOOL bRet = StopWDT()