

Neousys Technology Inc.

POC-764VR Series

User Manual

Revision 1.0

Table of Contents

Table of Contents	2
Legal Information	4
Contact Information	5
Declaration of Conformity	5
Copyright Notice	6
Safety Precautions	7
Service and Maintenance	8
ESD Precautions	8
About This Manual	9
1 Introduction	
1.1 Specification of POC-764VR	11
1.2 Dimension of POC-764VR	13
1.2.1 Front Panel View	13
1.2.2 Reserved Punch-out Panel View	14
1.2.3 COM Port/ DIO Panel View	14
1.2.4 Rear View	15
1.2.5 Bottom View	15
2 System Overview	
2.1 Unpacking the System	16
2.2 POC-764VR Series Front Panel	17
2.2.1 System Status LED	18
2.2.2 HDMI	19
2.2.3 DisplayPort	20
2.2.4 Reset Button	21
2.2.5 USB3.2 Gen2x1 Port	21
2.2.6 IEEE 802.3at Power over Ethernet Port	22
2.2.7 3-pin Terminal Block for DC/ Ignition Power Control Input	23
2.2.8 Hard Drive RAID Status LED	24
2.2.9 2.5" Hard Drive Tray	24
2.3 DIO/ COM Port Panel	25
2.3.1 Digital Input/ Output	26
2.3.2 COM 1 Port	28
2.3.3 COM Port (COM2/ COM3/ COM4)	29
2.3.4 Power Button	30
2.3.5 SMA Antenna Opening	31
2.4 CMOS Reset Button	32
2.5 Reserved Punch-out Panel	33
2.5.1 Ignition Rotary Switch	34
2.5.2 2.5Gb Ethernet Port	35
2.6 Internal I/O	36
2.6.1 Full-size mini-PCIe with SIM Slot on Motherboard	36
2.6.2 Full-sized mini-PCIe on MezzIO	38
2.6.3 M.2 2280 (M Key) Slot for SSD	40
2.6.4 SO-DIMM Socket	42
2.6.5 DIP Switch	43
3 System Installation	
3.1 Disassembling the System Enclosure	45
3.2 Installing Internal Components	48
3.2.1 DDR5 SO-DIMM Installation	48
3.2.2 M.2 2880 M Key SSD Installation	50
3.2.3 mini-PCIe Module, SIM Card and Antenna Installation	52
3.3 Installing the System Enclosure	55

3.4	2.5" HDD/SSD Installation.....	58
3.5	DIN Rail Installation.....	61
3.6	Horizontal Wall Mount Installation (Optional)	64
3.6.1	Vertical Wall Mount Bracket (Optional).....	66
3.7	Fan Kit Installation (Optional)	67
3.8	Powering On the System	69
3.8.1	Powering On Using the Power Button.....	69
3.8.2	Powering On Using Wake-on-LAN.....	70
3.9	Ignition Power Control	73
3.9.1	Principles of Ignition Power Control	73
3.9.2	Additional Features of Ignition Power Control	74
3.9.3	Wiring Ignition Signal	75
3.9.4	Configure your Windows system.....	76
3.9.5	Operation Modes of Ignition Power Control	77

4 BIOS Settings

4.1	COM1 Port Configuration	80
4.2	COM 2/ 3/ 4 Port Configuration	81
4.3	COM Port High Speed Mode.....	82
4.4	SATA Configuration.....	83
4.4.1	RAID-0 Mode	85
4.4.2	RAID-1 Mode	86
4.4.3	JBOD Mode	87
4.5	TPM Availability	88
4.6	Power over Ethernet (PoE)	89
4.7	Wake-on-LAN	90
4.8	C-States.....	91
4.9	Power On after Power Failure	93
4.10	Boot Menu.....	94
4.11	Position New Boot Device	96
4.12	Watchdog Timer.....	97

5 OS Support and Driver Installation

5.1	Operating System Compatibility	98
5.2	Driver Installation	99
5.3	Driver Installation for Watchdog Time Control	99

Appendix A Using WDT & DIO

WDT and DIO Library Installation	101
WDT Function Reference	103
InitWDT	103
SetWDT	103
StartWDT	104
ResetWDT	104
StopWDT	104
DIO Functions.....	105
InitDIO.....	105
DIReadLine	105
DIReadPort	105
DOWriteLine.....	106
DOWritePort.....	106

Appendix B PoE On/ Off Control

PoE On/ Off Control Function Reference	107
GetStatusPoEPort.....	107
EnablePoEPort.....	108
DisablePoEPort.....	109

Legal Information

All Neosys Technology Inc. products shall be subject to the latest Standard Warranty Policy

Neosys Technology Inc. may modify, update or upgrade the software, firmware or any accompanying user documentation without any prior notice. Neosys Technology Inc. will provide access to these new software, firmware or documentation releases from download sections of our website or through our service partners.

Before installing any software, applications or components provided by a third party, customer should ensure that they are compatible and interoperable with Neosys Technology Inc. product by checking in advance with Neosys Technology Inc.. Customer is solely responsible for ensuring the compatibility and interoperability of the third party's products. Customer is further solely responsible for ensuring its systems, software, and data are adequately backed up as a precaution against possible failures, alternation, or loss.

For questions in regards to hardware/ software compatibility, customers should contact Neosys Technology Inc. sales representative or technical support.

To the extent permitted by applicable laws, Neosys Technology Inc. shall NOT be responsible for any interoperability or compatibility issues that may arise when (1) products, software, or options not certified and supported; (2) configurations not certified and supported are used; (3) parts intended for one system is installed in another system of different make or model.

Contact Information

Headquarters
(Taipei, Taiwan) **Neosys Technology Inc.**
15F, No.868-3, Zhongzheng Rd., Zhonghe Dist., New Taipei City, 23586, Taiwan
Tel: +886-2-2223-6182 Fax: +886-2-2223-6183 [Email](#), [Website](#)

Americas
(Illinois, USA) **Neosys Technology America Inc.**
3384 Commercial Avenue, Northbrook, IL 60062, USA
Tel: +1-847-656-3298 [Email](#), [Website](#)

China **Neosys Technology China Co., Ltd.**
Room 612, Building 32, Guiping Road 680, Shanghai
Tel: +86-2161155366 [Email](#), [Website](#)

Declaration of Conformity

FCC This equipment has been tested and found to comply with the limits for a Class A digital device, pursuant to part 15 of the FCC Rules. These limits are designed to provide reasonable protection against harmful interference when the equipment is operated in a commercial environment. This equipment generates, uses, and can radiate radio frequency energy and, if not installed and used in accordance with the instruction manual, may cause harmful interference to radio communications. Operation of this equipment in a residential area is likely to cause harmful interference in which case the user will be required to correct the interference at own expense.

CE The product(s) described in this manual complies with all applicable European Union (CE) directives if it has a CE marking. For computer systems to remain CE compliant, only CE-compliant parts may be used. Maintaining CE compliance also requires proper cable and cabling techniques.

Copyright Notice

All rights reserved. This publication may not be reproduced, transmitted, transcribed, stored in a retrieval system, or translated into any language or computer language, in any form or by any means, electronic, mechanical, magnetic, optical, chemical, manual or otherwise, without the prior written consent of Neosys Technology, Inc.

Disclaimer

This manual is intended to be used as an informative guide only and is subject to change without prior notice. It does not represent commitment from Neosys Technology Inc. Neosys Technology Inc. shall not be liable for any direct, indirect, special, incidental, or consequential damages arising from the use of the product or documentation, nor for any infringement on third party rights.

Patents and Trademarks

Neosys, the Neosys logo, Expansion Cassette, MezIO™ are registered patents and trademarks of Neosys Technology, Inc.

Windows is a registered trademark of Microsoft Corporation.

AMD, Ryzen™ are registered trademarks of Advanced Micro Devices, Inc

All other names, brands, products or services are trademarks or registered trademarks of their respective owners.

Safety Precautions

- Read these instructions carefully before you install, operate, or transport the system.
- Install the system or DIN rail associated with, at a sturdy location
- Install the power socket outlet near the system where it is easily accessible
- Secure each system module(s) using its retaining screws
- Place power cords and other connection cables away from foot traffic. Do not place items over power cords and make sure they do not rest against data cables
- Shutdown, disconnect all cables from the system and ground yourself before touching internal modules
- Ensure that the correct power range is being used before powering the device
- Should a module fail, arrange for a replacement as soon as possible to minimize down-time
- If the system is not going to be used for a long time, disconnect it from mains (power socket) to avoid transient over-voltage

Service and Maintenance

- ONLY qualified personnel should service the system
- Shutdown the system, disconnect the power cord and all other connections before servicing the system
- When replacing/ installing additional components (expansion card, memory module, etc.), insert them as gently as possible while assuring proper connector engagement

ESD Precautions

- Handle add-on module, motherboard by their retention screws or the module's frame/ heat sink. Avoid touching the PCB circuit board or add-on module connector pins
- Use a grounded wrist strap and an anti-static work pad to discharge static electricity when installing or maintaining the system
- Avoid dust, debris, carpets, plastic, vinyl and styrofoam in your work area.
- Do not remove any module or component from its anti-static bag before installation

About This Manual

This manual introduces and demonstrates installation procedures of Neosys POC-764VR series systems featuring an Intel® Core™ i3-N305 8-core processor. The manual also demonstrates the system's general installation procedures.

Revision History

Version	Date	Description
1.0	Dec 2024	Initial release

1 Introduction

POC-764VR is Neosys' next-generation fanless ultra-compact surveillance computer platform. Built on the foundation of the POC-764VR series with advanced RAID storage and enhanced networking capabilities, the system is ideal for surveillance, security, and smart city applications while ensuring data redundancy, reliability, and seamless connectivity in critical environments.



Featuring four Gigabit PoE+ ports with locking mechanisms and ignition function, POC-764VR can connect up to four IP/ POE cameras for mobile surveillance systems, where it ensures reliable connectivity and power in dynamic environments. Additionally, it also accommodates dual 2.5" HDD/SSDs with RAID 0/1 configuration for enhanced data redundancy and backup, accommodating up to two 8TB drives, enabling continuous 1080p video recording in H.264 format for over 30 days. The addition of a network port provides more flexibility for data transmission. As for connections and expansions, POC-764VR features two mini-PCIe sockets for wireless WiFi, LTE/5G or CAN bus device.

Powered by Intel's Alder Lake i3-N305, an 8-core/8-thread processor with 32EUs UHD Graphics, POC-764VR can utilize Intel OpenVINO™ for real-time AI inference. Combining powerful CPU performance, graphics capabilities, and extensive video storage expansion, the POC-764VR is perfect for applications such as image and object recognition, public safety monitoring, security surveillance, and asset management.

1.1 Specification of POC-764VR

System Core	
Processor	Intel® Alder Lake Core™ i3-N305 processor (8C/8T, 1.8/3.8 GHz, 15W TDP)
Graphics	Integrated Intel® HD Graphics with 32EUs
Memory	Up to 16 GB DDR5-4800 SDRAM (one SODIMM socket)
TPM	Supports dTPM 2.0
Panel I/O Interface	
Ethernet	4x Gb Ethernet ports by Intel® I350-AM4 (port #1~4) 1x 2.5Gb Ethernet port by Intel® I226-IT (port #5)
PoE+	IEEE 802.3at PoE+ on port #1- 4
Native Video Port	1x DP++, Supporting 4096 x 2160 resolution 1x HDMI1.4b, Supporting 3840 x 2160 @ 30Hz
Serial Port	1x Software-programmable RS-232/422/485 port (COM1) 3x 3-wire RS-232 ports (COM2/3/4) or 1x RS-422/485 port (COM2)
USB	4x USB 3.2 Gen2 ports with screw-lock
Isolated DIO	4-CH isolated DI and 4-CH isolated DO
Internal I/O Expansion Interface	
Mini PCI-E	2x full-size mini PCI Express socket with internal micro SIM socket
Storage Interface	
M.2	1x M.2 2280 M key socket (PCIe Gen3 x1) for NVMe SSD storage (supports SATA signal)
SATA	2x internal SATA port for 2.5" SSD installation, supporting hardware RAID 0/ 1/ JBOD (hot-swappable functionality in RAID1 mode only)
Power Supply	
DC input	1x 3-pin pluggable terminal block for 8V to 35V DC input
Mechanical	
Dimension	175.8 mm (W) x 115.5 mm (D) x 67.9 mm (H)
Weight	1.45kg
Mounting	DIN-rail mount (standard) or wall-mount (optional)
Fan kit	Optional external-accessible fan kit 80mm x 80mm
Environmental	

Operating temperature	With fan kit -25°C to 70°C */** Without fan kit -10°C to 55°C *
Storage temperature	-40°C to 85°C
Humidity	10% to 90%, non-condensing
Vibration	MIL-STD-810H, Method 514.8, Category 4
Shock	MIL-STD-810H, Method 516.8, Procedure I
EMC	CE/ FCC Class A, according to EN 55032 & EN 55035

* For sub-zero and over 60°C operating temperature, a wide temperature Solid State Disk (SSD) is required.

** The optional fan kit is recommended for operating at ambient temperatures higher than 55°C.

1.2 Dimension of POC-764VR

 NOTE

All measurements are in millimeters (mm).

1.2.1 Front Panel View

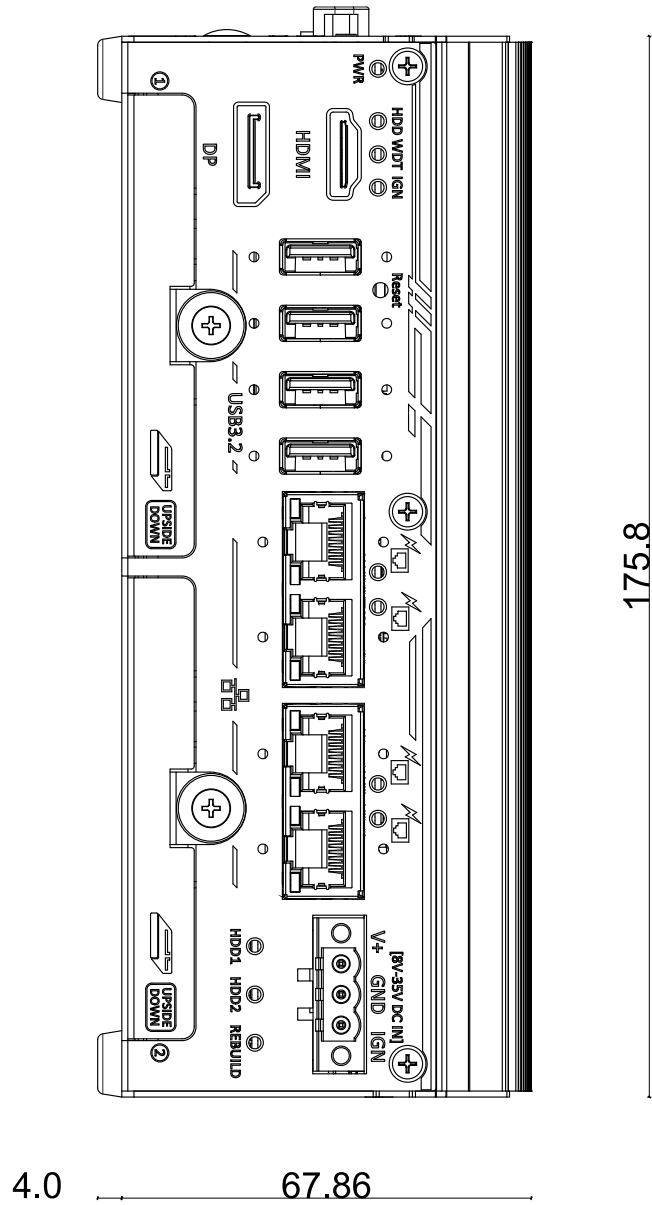

1.2.2 Reserved Punch-out Panel View

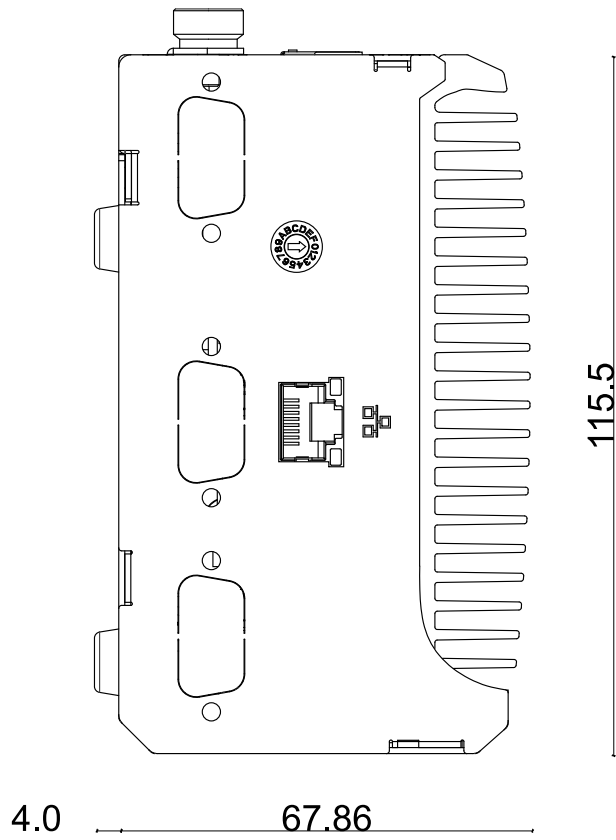

1.2.3 COM Port/ DIO Panel View

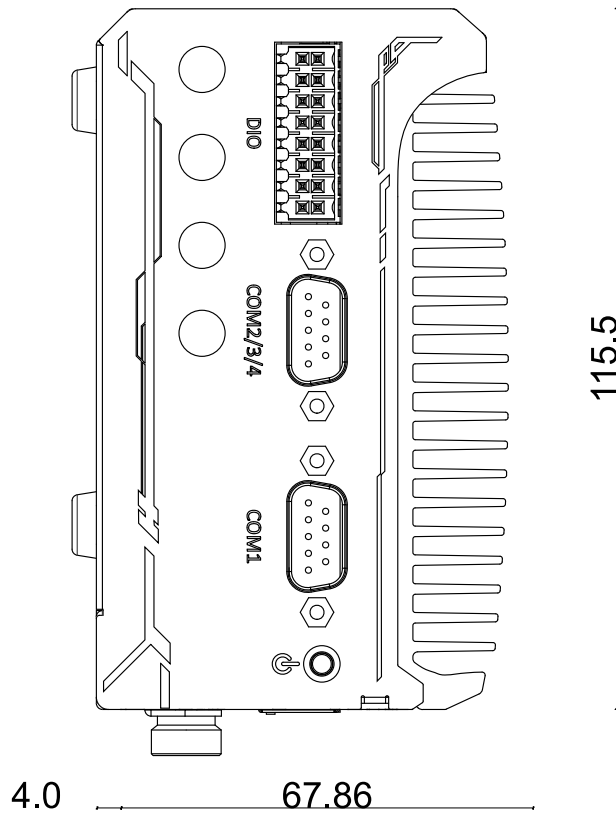

1.2.4 Rear View

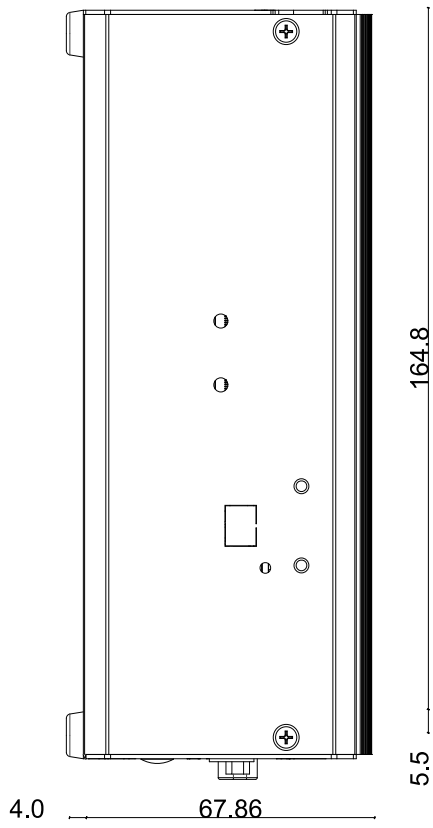

1.2.5 Bottom View

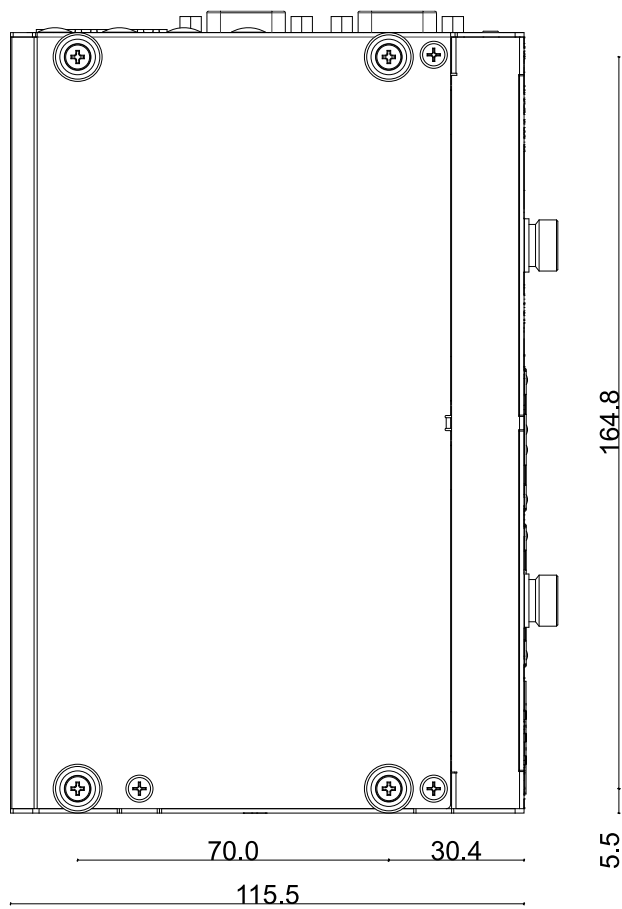

2 System Overview

Upon receiving and unpacking your POC-764VR systems, please check immediately if the package contains all the items listed in the following table. If any item(s) are missing or damaged, please contact your local dealer or Neousys Technology.

2.1 Unpacking the System

Item	Description	Qty
1	POC-764VR (Please verify ordered items such as CPU, RAM, HDD, etc.)	1
2	Accessory box, which contains <ul style="list-style-type: none">● DIN-Rail Mount Clip● 3-pin power terminal block● 16-pin DIO terminal block● Screw pack	1 1 1 1

2.2 POC-764VR Series Front Panel

The front panel of POC-764VR series features four PoE+ Gigabit Ethernet ports, four USB 3.1 Gen1 ports, HDMI, DisplayPort, 3-pin terminal block for DC input, and two 2,5" HDD trays.

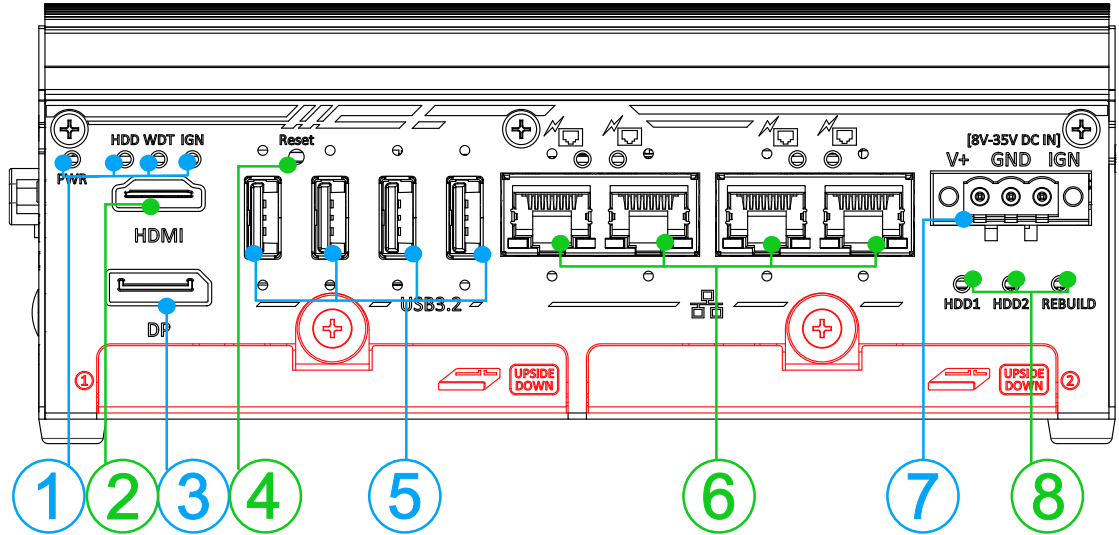

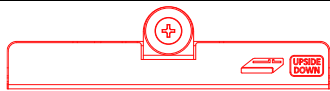
No.	Item	Description
1	System status LED	System LEDs, Hard Disk Drive (HDD), Watchdog Timer (WDT), Ignition control (IGN).
2	HDMI	The HDMI port is a high-resolution graphics/ data port supporting up to 3840 x 2160 @ 30Hz.
3	DisplayPort output	The DisplayPort is a high-resolution graphics output supporting up to 4096 x 2160 @ 60Hz.
4	Reset button	Use this button to manually reset the system.
5	USB3.2 Gen2x1 port	USB3.2 Gen 2 port (SuperSpeed+) offers up to 10Gbps, twice the bandwidth over existing SuperSpeed USB3.2 Gen. 1 connection. It is also backwards compatible with USB3.0 and USB2.0
6	Ethernet & PoE+	4x Gb Ethernet ports by Intel® I350-AM4 with Power over Ethernet port that can provide both data and electric power to devices.
7	3-pin DC terminal block with ignition power control	Compatible with DC power input from 8V - 35V with ignition power control signal input.
8	HDD status LED	The LEDs specifically indicates activity for each HDD and RAID rebuild status.
		Two 2.5" HDD trays supporting drives up to 9.5mm drives

2.2.1 System Status LED

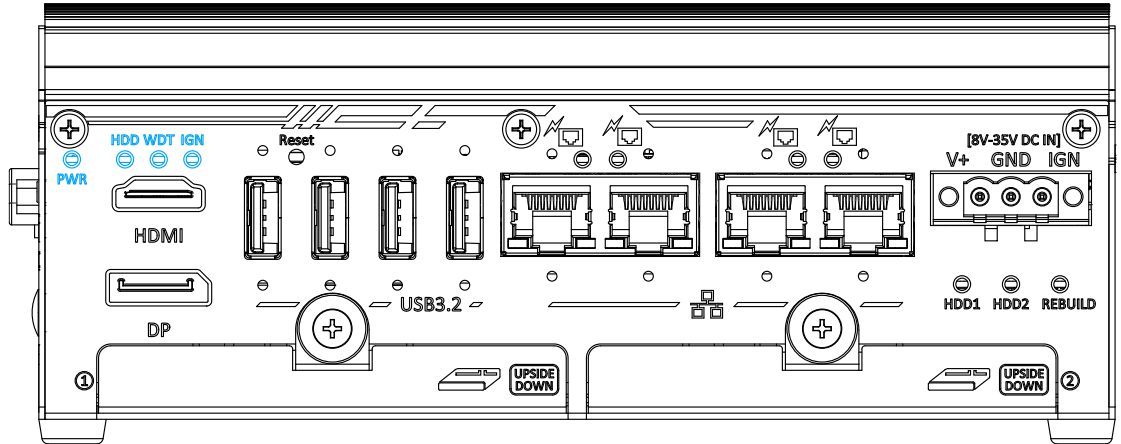

There are three LED indicators on the front panel: HDD, WDT and IGN. The descriptions of these LEDs are listed in the following table.

Indicator	Color	Description
PWR	Green	Power indicator, lit when system is on.
HDD	Red	Hard drive indicator, flashing when SATA HDD is active
WDT	Yellow	Watchdog timer indicator, flashing when watchdog timer has started
IGN	Yellow	Ignition power control, lit when IGN signal is applied.

2.2.2 HDMI

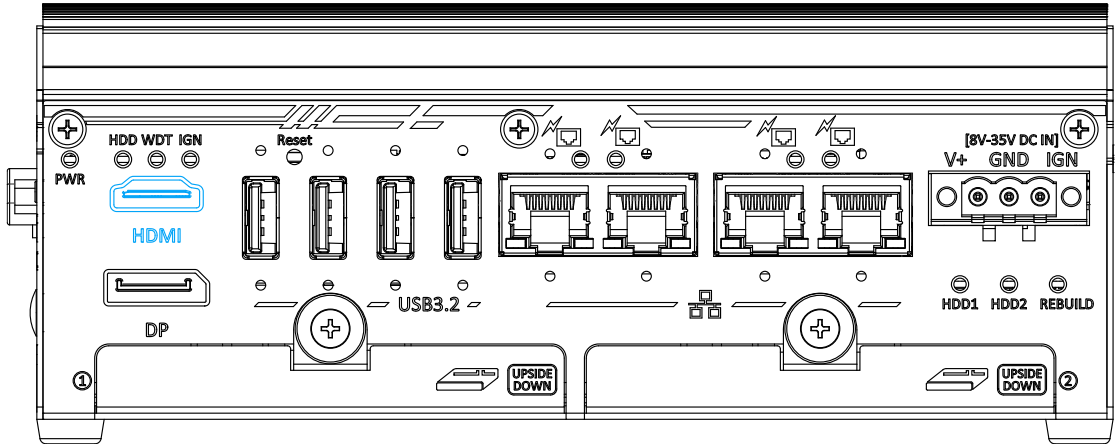

The High-Definition Multimedia Interface (HDMI) port provides uncompressed high-quality digital video and audio transmission between the system and a multimedia display device on a single cable. You can connect to other digital inputs by using a HDMI-to-DVI or HDMI-to-DP cable.



HDMI-to-DP

The system supports dual independent display outputs by connecting display devices to HDMI and DisplayPort connection. To support dual display outputs and achieve best DisplayPort output resolution in Windows, you need to install corresponding graphics drivers. Please refer to section [OS Support and Driver Installation](#) for details.

2.2.3 DisplayPort

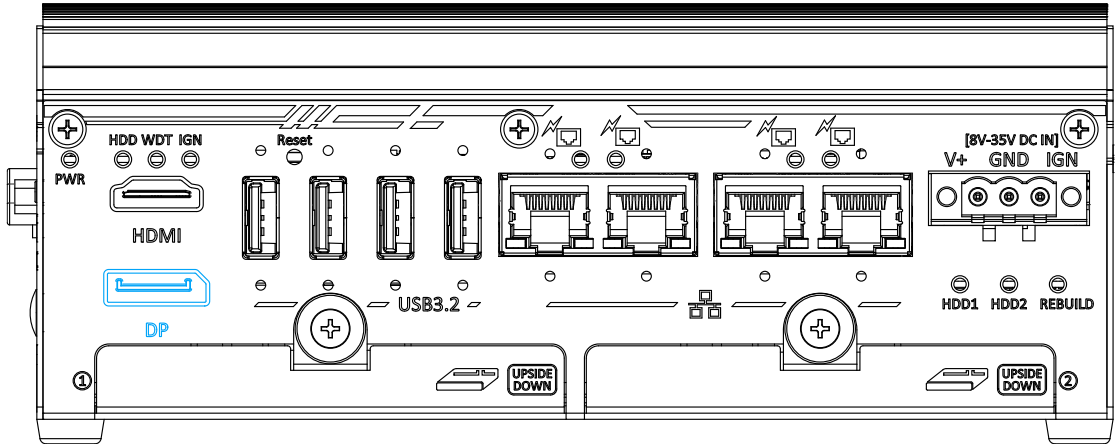

The system has a DisplayPort (DP) output which is a digital display interface that mainly connect video source and carry audio to a display device. When connecting a DP, it can deliver up to 4K UHD (4096 x 2160 @ 60Hz) in resolution. The system is designed to support passive DP adapter/ cable. You can connect to other display devices using DP-to-HDMI cable or DP-to-DVI cable.



DP-to-HDMI



DP-to-DVI

The system supports dual independent display outputs by connecting display devices to HDMI and DisplayPort connection. To support dual display outputs and achieve best DisplayPort output resolution in Windows, you need to install corresponding graphics drivers. Please refer to section [OS Support and Driver Installation](#) for details.

2.2.4 Reset Button

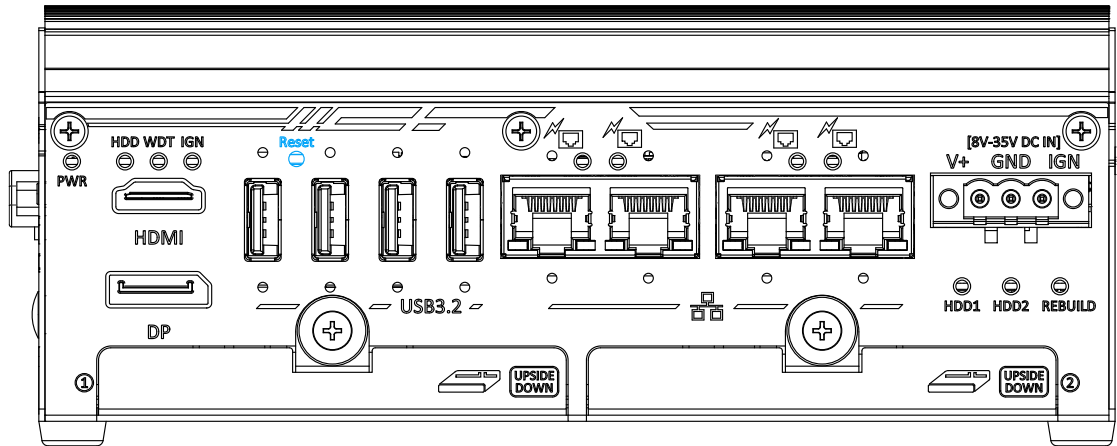

The reset button is used to manually reset the system in case of system halt or malfunction. To avoid unexpected reset, the button is purposely placed behind the panel. To reset, please use a pin-like object (eg. tip of a pen) to access the reset button

2.2.5 USB3.2 Gen2x1 Port

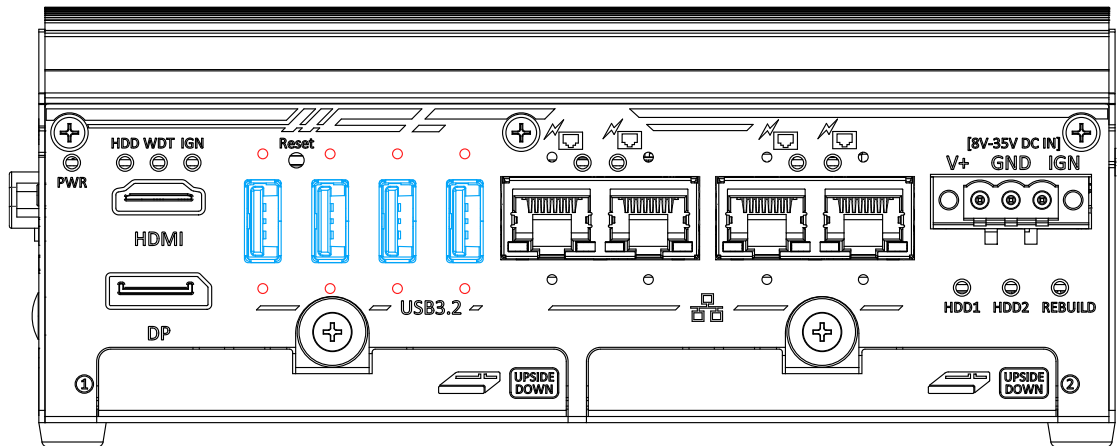

The system's USB 3.2 Gen2x1 ports (10Gbps) are implemented via native xHCI (eXtensible Host Controller Interface) controller and are backward compatible with USB3.2 Gen.1 USB 2.0, USB 1.1 and USB 1.0 devices. UEFI USB is also supported so you can use USB keyboard/ mouse in UEFI shell environment. Indicated in **red** are screw-lock holes for the corresponding USB port.

xHCI driver is supported natively in Windows 10, therefore you do not need to install the xHCI driver prior to utilizing USB functions.

2.2.6 IEEE 802.3at Power over Ethernet Port

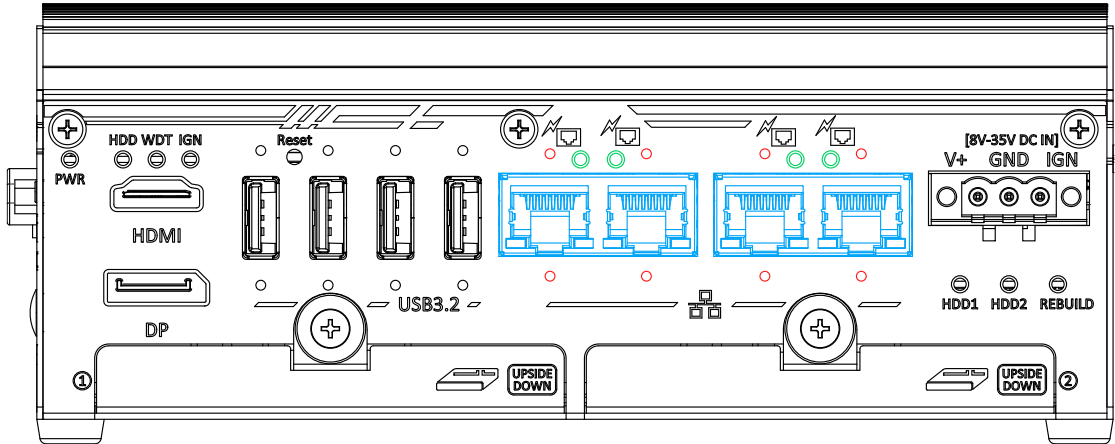

The system offers four Gb Ethernet ports via Intel® I350-AM4 and is backward compatible with 100/ 10Mb connection speeds.

The Gigabit Power over Ethernet (PoE) ports can supply power and transmit data on a standard CAT-5/CAT-6 Ethernet cable. Acting as a PSE (Power Sourcing Equipment), compliant with IEEE 802.3at, each port delivers up to 25W to a Powered Device (PD). PoE automatically detects and determine if the connected device is PoE PD or not before supplying power, making it compatible with standard Ethernet devices as well. Indicated in **red** is a screw-lock hole for the corresponding Ethernet port, and indicated in **green** is the status LED for each corresponding Ethernet por.

Active/Link LED (Right)

LED Color	Status	Description
Green	Off	Ethernet port is disconnected
	On	Ethernet port is connected and no data transmission
	Flashing	Ethernet port is connected and data is transmitting/receiving

Speed LED (Left)

LED Color	Status	Description
Green or Orange	Off	10 Mbps
	Green	100 Mbps
	Orange	1000 Mbps

2.2.7 3-pin Terminal Block for DC/ Ignition Power Control Input

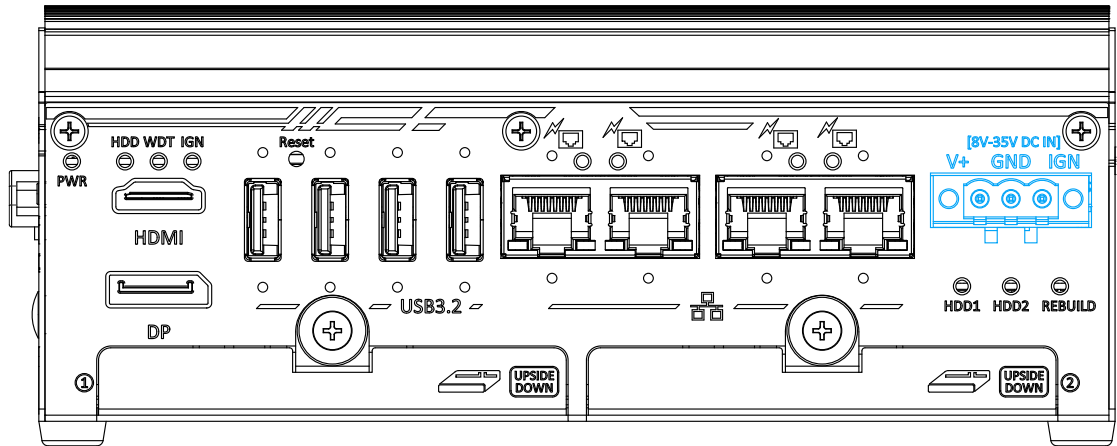

The system accepts a wide range of DC power input from 8V to 35V via a 3-pin pluggable terminal block, which is fit for field usage where DC power is usually provided. The screw clamping mechanism on the terminal block offers connection reliability when wiring DC power.

In addition to DC power input, this terminal block can also accept ignition signal input (IGN).

 **WARNING**

Please make sure the voltage of DC power is correct before you connect it to the system. Supplying a voltage over 35V will damage the system.

2.2.8 Hard Drive RAID Status LED

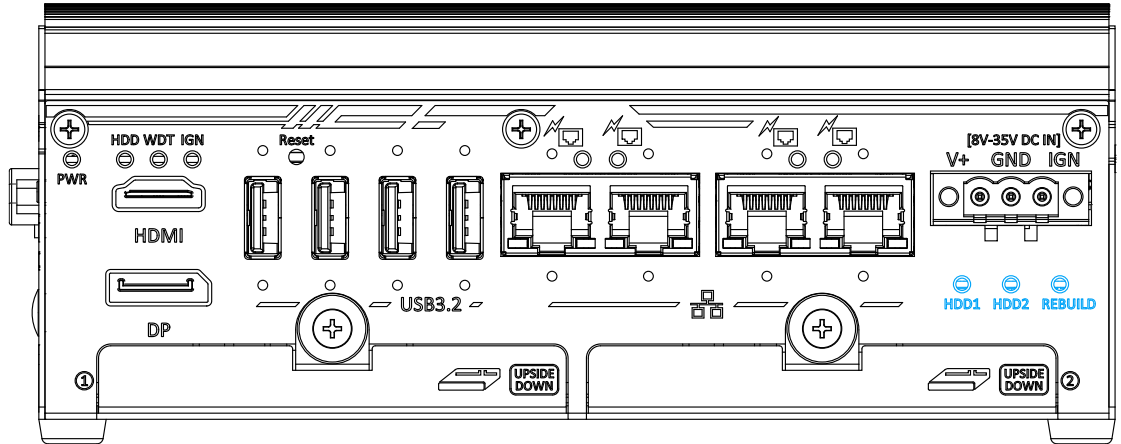

The system supports two 2.5" hard drives and can be setup in RAID 0/ 1/ JBOD configurations. Depending on their actions, the LEDs indicates the following:

Action	LED	HDD1	HDD2	REBUILD
HDD not detected		Steady on	Steady on	Steady off
HDD installed		Steady off	Steady off	Steady off
Read/ write data		Flashing	Flashing	Steady off
RAID 1 Rebuilding		Flashing	Flashing	Flashing
Rebuild complete		Steady off	Steady off	Steady off

2.2.9 2.5" Hard Drive Tray

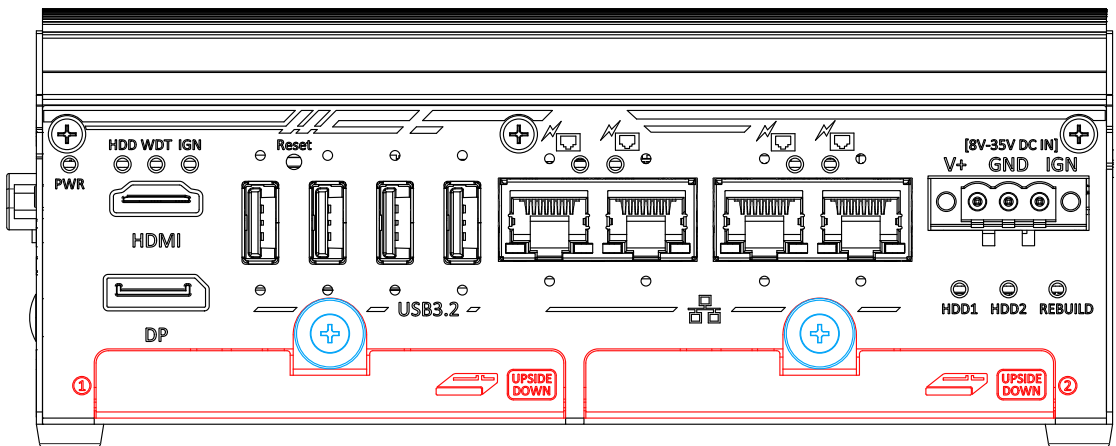

The system comes with two 2.5" drive trays that support HDD/ SSD between 7-9.5mm in height. The trays can be removed by turning the thumb-screw (indicated in **blue**) in anti-clockwise direction.

2.3 DIO/ COM Port Panel

The COM port panel of POC-764VR series features additional I/O functions, such as digital input/ output, COM ports, and reserved antenna openings for SMA antenna installation. In addition, the power button can also be located on this panel.

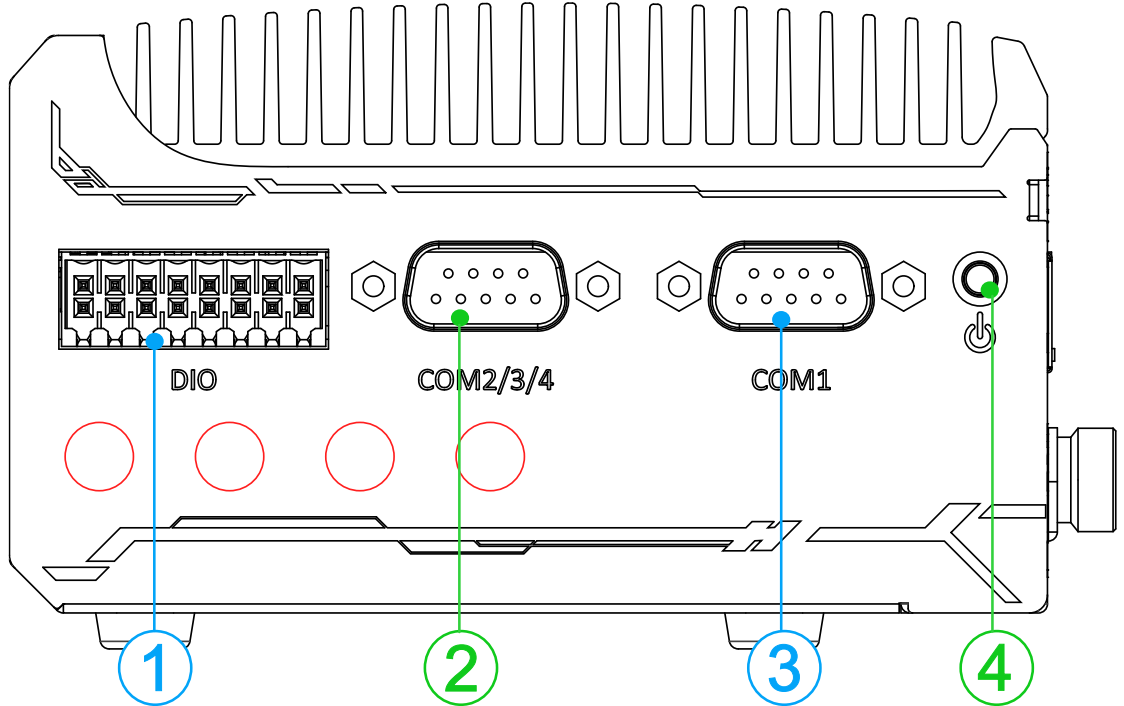

No.	Item	Description
1	Digital I/O	4 channel isolated digital input 4 channel isolated digital output
2	COM port 2/ 3/ 4	Can be configured as: COM2: single RS-422/ 485 port COM2/ COM3/ COM4: three 3-wire RS-232 ports
3	COM port 1	Software programmable RS-232/ 422/ 485 port.
4	Power button	Use this button to turn on or shutdown the system.
		Opening reserved for SMA antenna installation.

2.3.1 Digital Input/ Output

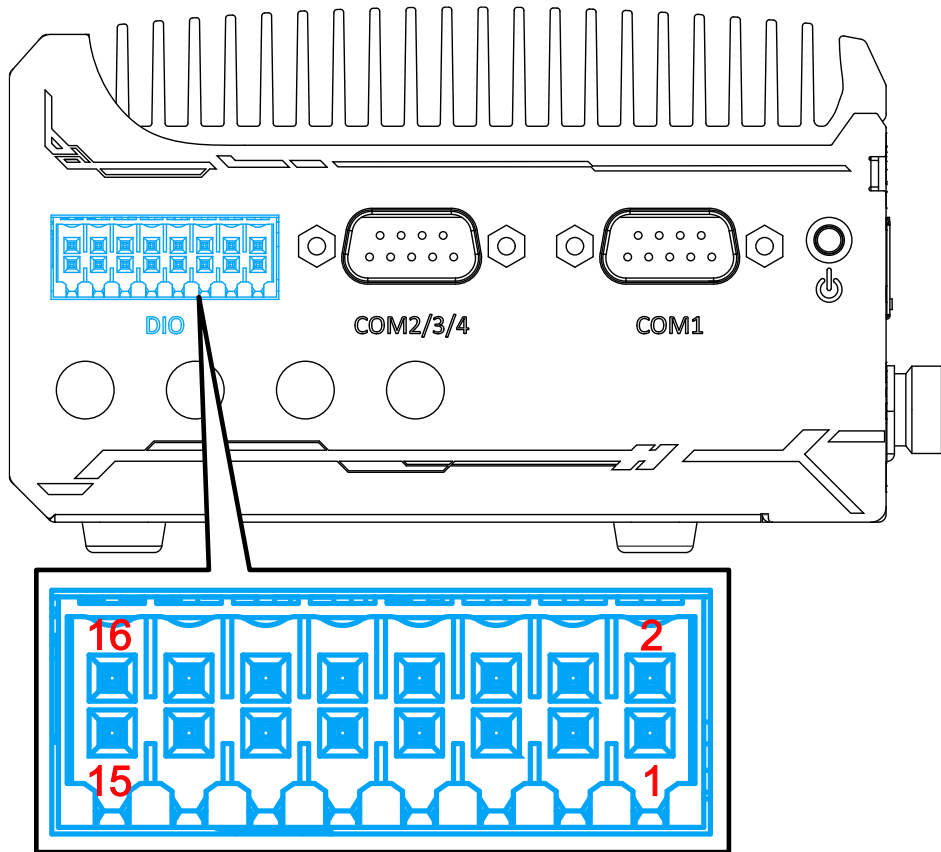

The system provides 4x isolated digital input channels and 4x isolated digital output channels. The DIO functions support polling mode I/O access and DI change-of-state interrupt. Please refer to [Watchdog Timer & Isolated DIO](#) for information on wiring and programming the isolated DIO channels.

Pin#	Pin Definition	Pin#	Pin Definition
1	ISO_DI0_CN	9	ISO_DO0_CN
2	IGND0	10	EOGND
3	ISO_DI1_CN	11	ISO_DO1_CN
4	IGND1	12	EOGND
5	ISO_DI2_CN	13	ISO_DO2_CN
6	IGND2	14	EOGND
7	ISO_DI3_CN	15	ISO_DO3_CN
8	IGND3	16	VDD

*When using DO0 ~ DO3, DOGND is the ground should be used.

Wiring for DIO

The digital input function is implemented using a photo-coupler with an internally series-connected 1kΩ resistor. You need to provide a voltage to specify the logic high/low state. The input voltage for logic high is 5~24V, and the input voltage for logic low is 0~1.5V.

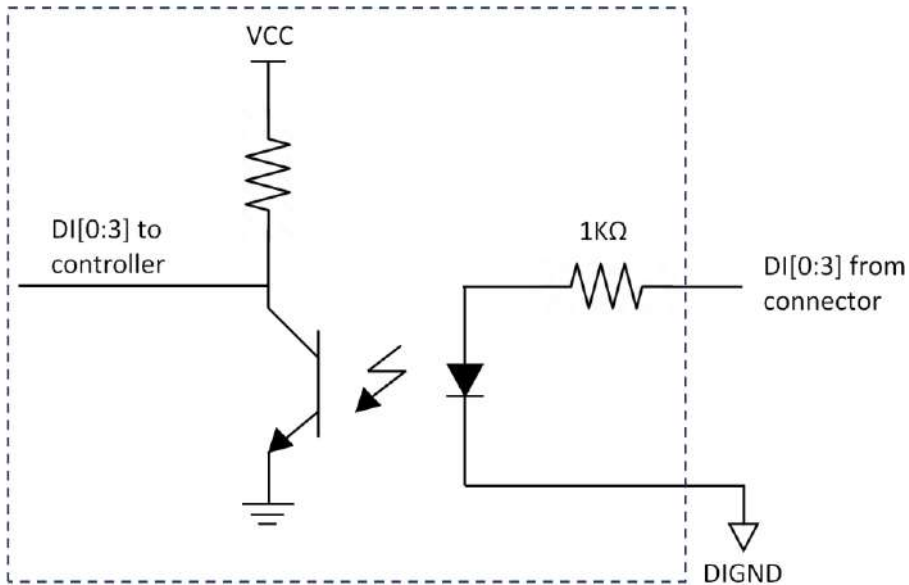

The digital output function is implemented using Power MOSFET + Analog Device iCoupler® component. The DO channels are configured as NO (normally-open) configuration. When you turn on the system, all DO channels have a deterministic state of logic 0 (circuit disconnected from GND return). When logic 1 is specified, MOSFET is activated and GND return path is established. The digital output function on the system supports sinking current connection. The following diagrams are the suggested wiring for DO:

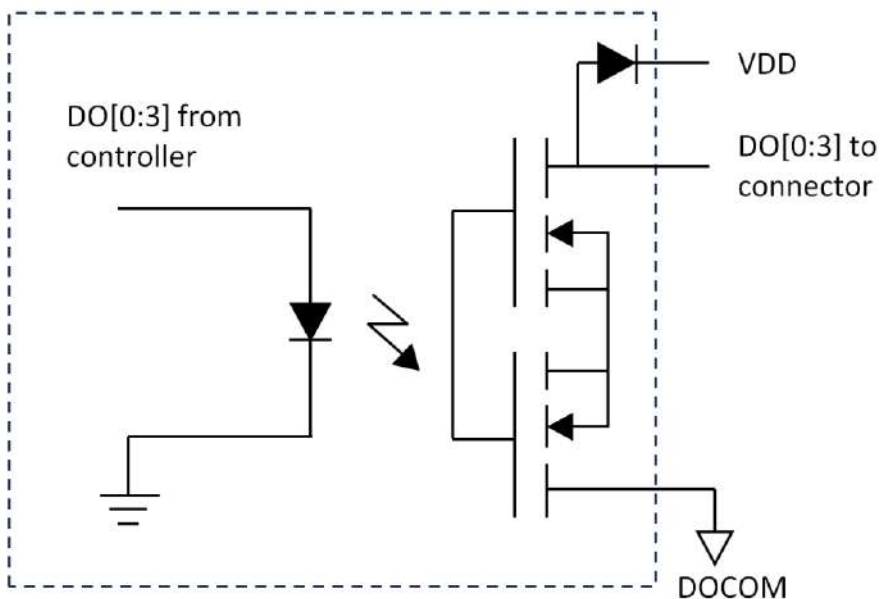

2.3.2 COM 1 Port

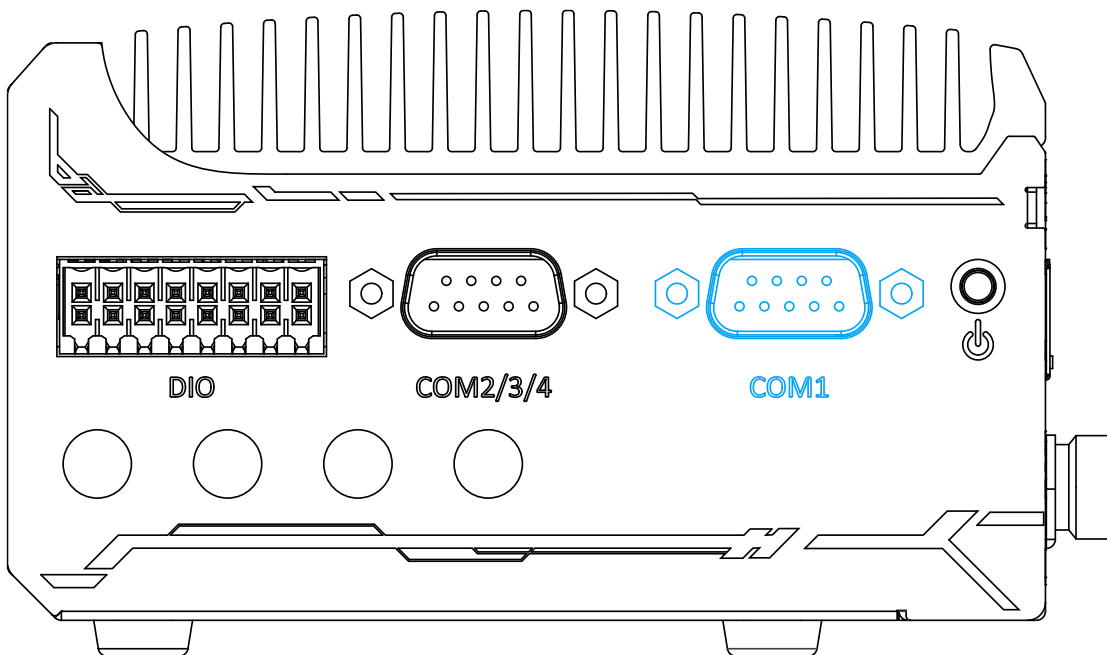

Implemented using industrial-grade ITE8786 Super IO chip (-40 to 85°C) and provide up to 921600 bps baud rate, COM1 is a software-configurable RS-232/422/485 port via 9-pin D-Sub male connector. The operation mode, slew rate and termination of COM1 can be set in BIOS setup utility. The following table describes the pin definition of COM ports.

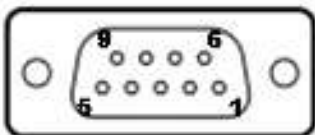

Pin#	COM1		
	RS-232 Mode	RS-422 Mode	RS-485 Mode (Two-wire 485)
1	DCD		
2	RX	422 TXD+	485 TXD+/RXD+
3	TX	422 RXD+	
4	DTR	422 RXD-	
5	GND	GND	GND
6	DSR		
7	RTS		
8	CTS	422 TXD-	485 TXD-/RXD-
9	RI		

2.3.3 COM Port (COM2/ COM3/ COM4)

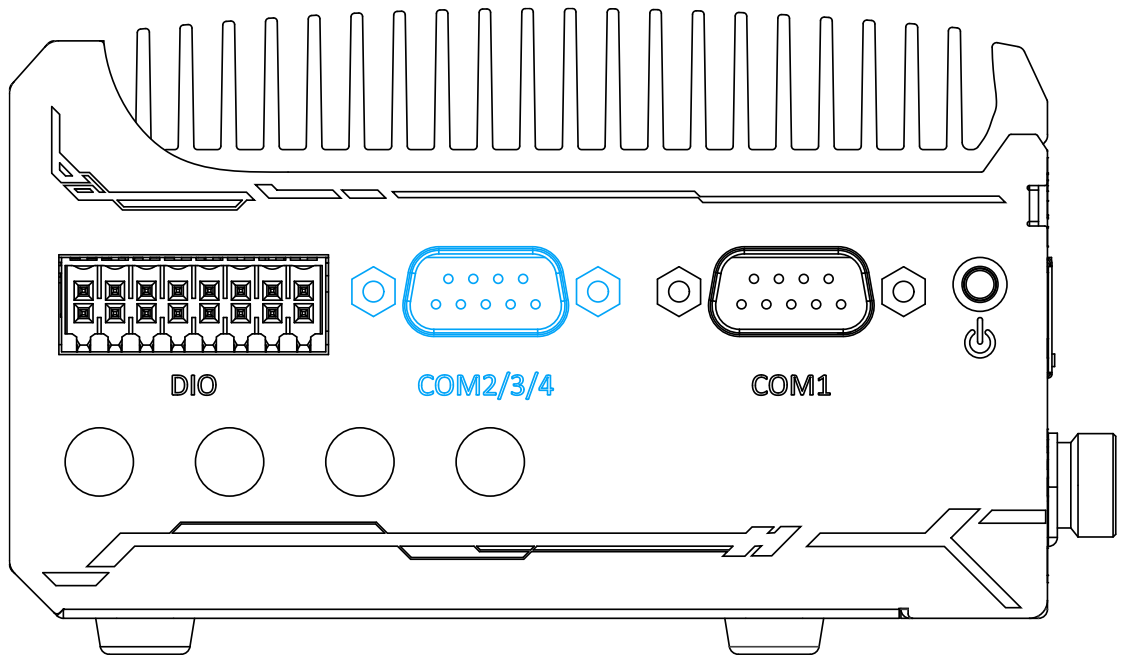

Implemented using industrial-grade ITE8786 Super IO chip (-40 to 85°C) and provide up to 921600 bps baud rate, the D-Sub male connector (COM2/ 3/ 4) can be configured in the BIOS as single RS-422/ 485 port (COM2) or three 3-wire RS-232 ports (COM2/COM3/COM4). Please refer to [COM2/ 3/ 4 Port Configuration](#) for configuring operation mode. An optional 1-to-3 Y-cable is available to connect three RS-232 devices.

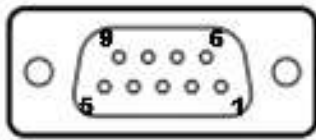

COM2/ 3/ 4 Pin



1-to-3 Y-cable

The following table describes the pin definition of the COM port

	3-port RS-232 COM2/ 3/ 4		
Pin#	COM2	COM3	COM4
1			
2	RX		
3	TX		
4		TX	
5	GND	GND	GND
6		RX	
7			TX
8			RX
9			

	Single port RS-422/ 485 COM2	
Pin#	RS-422	RS-485
1		
2	TxD+	TxD+/ RxD+
3	RxD+	
4	RxD-	
5	GND	GND
6		
7		
8	TxD-	TxD-/ RxD-
9		

2.3.4 Power Button

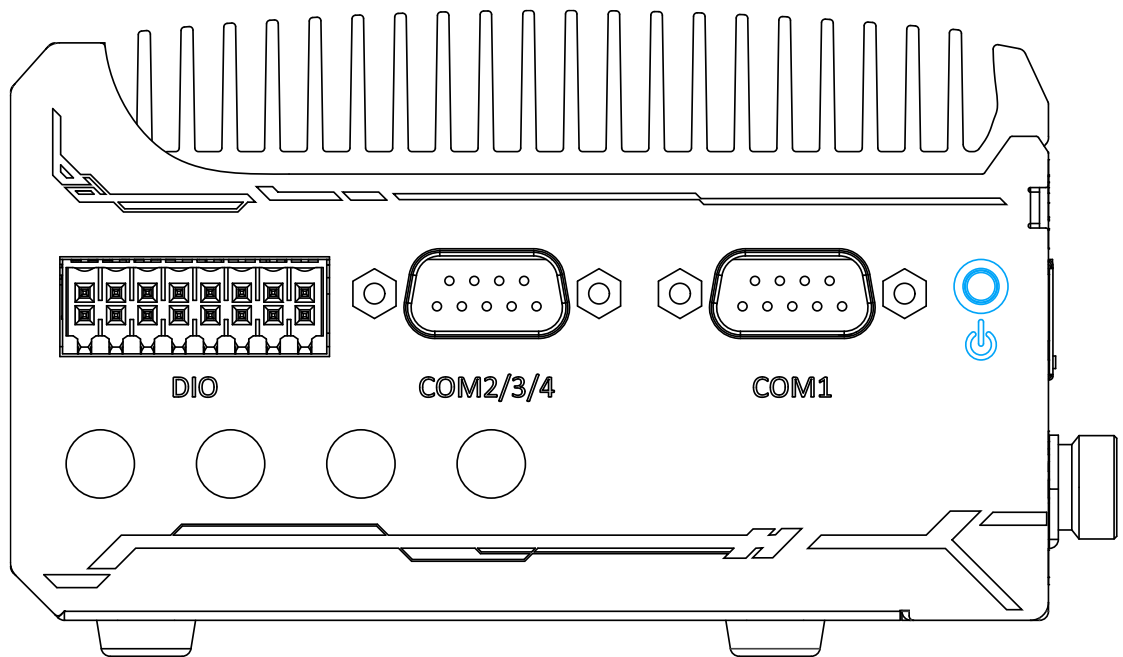

The power button is a non-latched switch for ATX mode on/off operation. Press to turn on the system, PWR LED should light up and to turn off, you can either issue a shutdown command in the OS, or just press the power button. In case of system halts, you can press and hold the power button for 5 seconds to force-shutdown the system. Please note that there is a 5 seconds interval between two on/off operations (i.e. once turning off the system, you will need to wait for 5 seconds to initiate another power-on operation).

2.3.5 SMA Antenna Opening

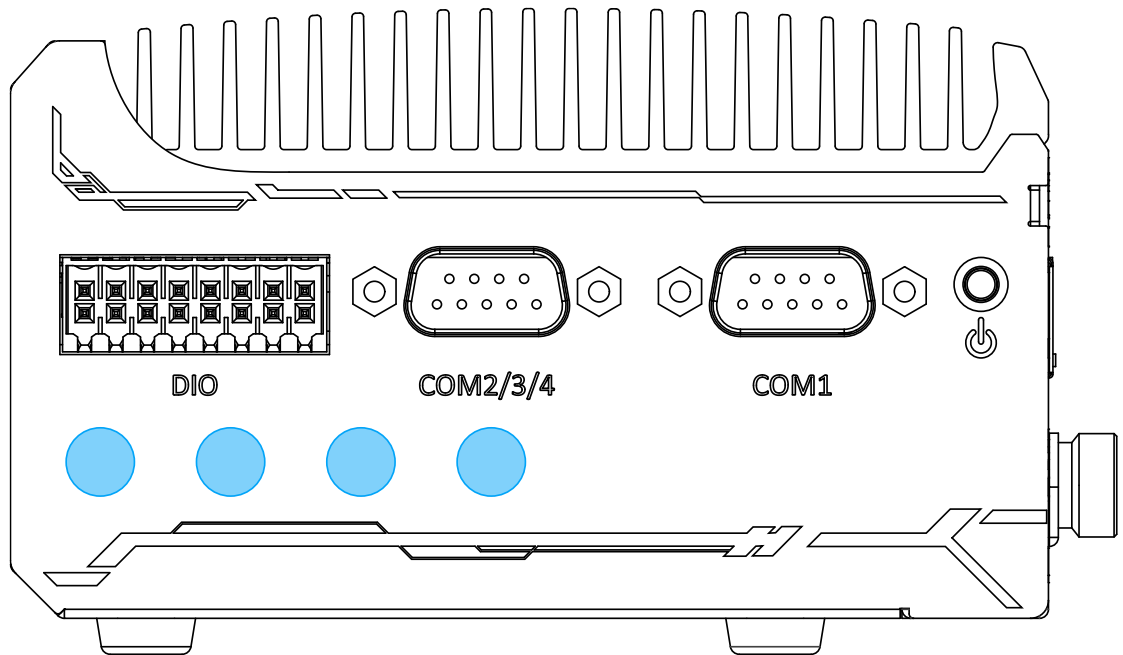

The system offers three SMA antenna openings reserved for SMA antenna installations. Users can take advantage of these three openings when installing mini-PCIe module for wireless communication reception such as 3G, 4G, GPS or WiFi.

2.4 CMOS Reset Button

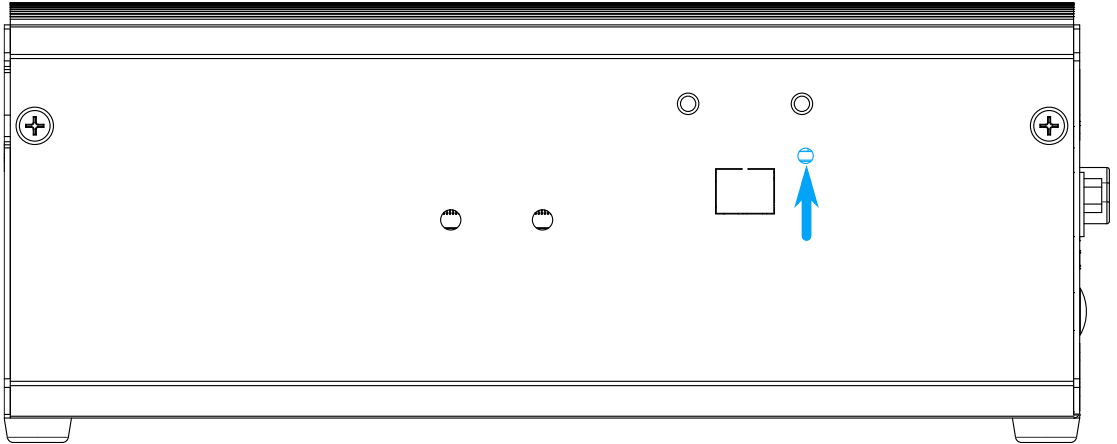

Positioned on the rear panel (opposite the IO panel), indicated by the **blue arrow**, the CMOS Reset button is used to manually reset the motherboard BIOS in case of system halt or malfunction. To avoid unexpected operation, it is purposely placed behind the panel. To reset, please use the tip of a pen, press and hold for at least 5 seconds to reset the BIOS.

2.5 Reserved Punch-out Panel

The reserved punch-out panel has reserved DB9 openings, ignition rotary switch, and an Ethernet port.

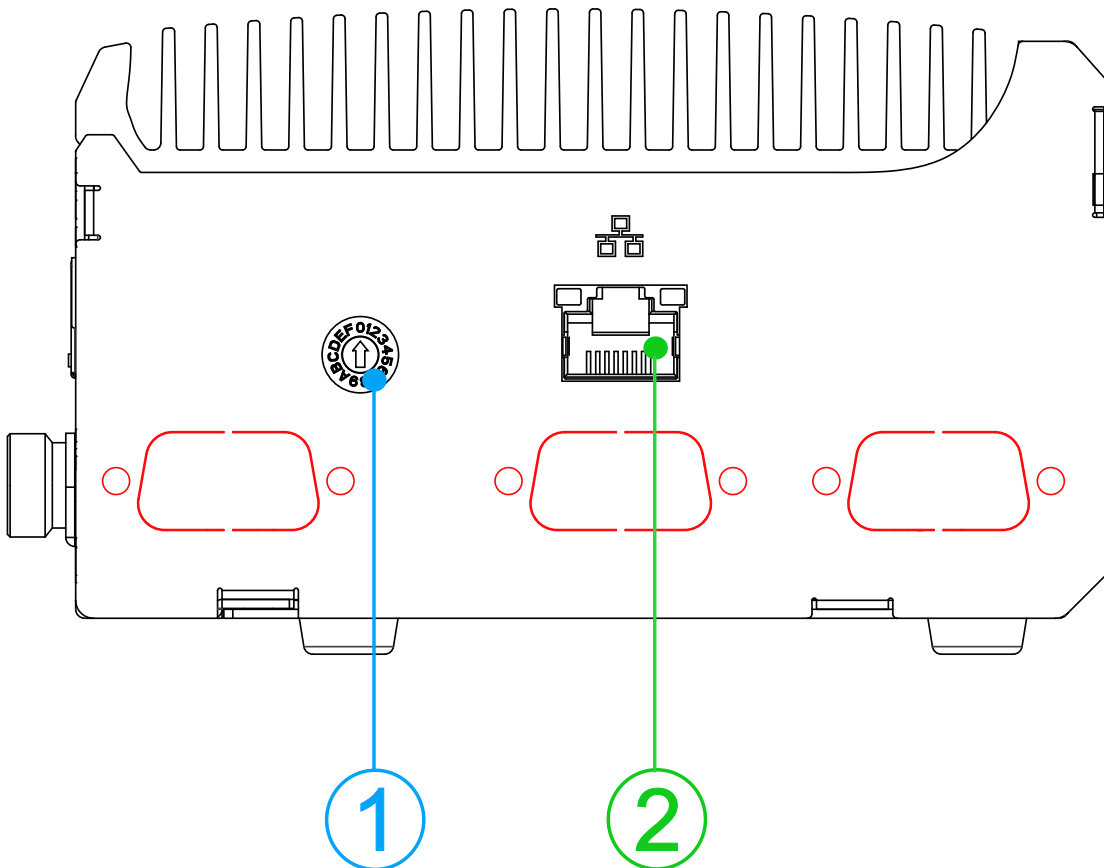

No.	Item	Description
1	Ignition rotary switch	The ignition rotary switch allows you to set computer delay on/off timings to avoid electrical spikes when turning on/ off the vehicle.
2	2.5Gb Ethernet port	Additional 2.5Gb Ethernet port by Intel® I226-IT for data logging and transmission.
		Opening reserved for SMA antenna installation.

2.5.1 Ignition Rotary Switch

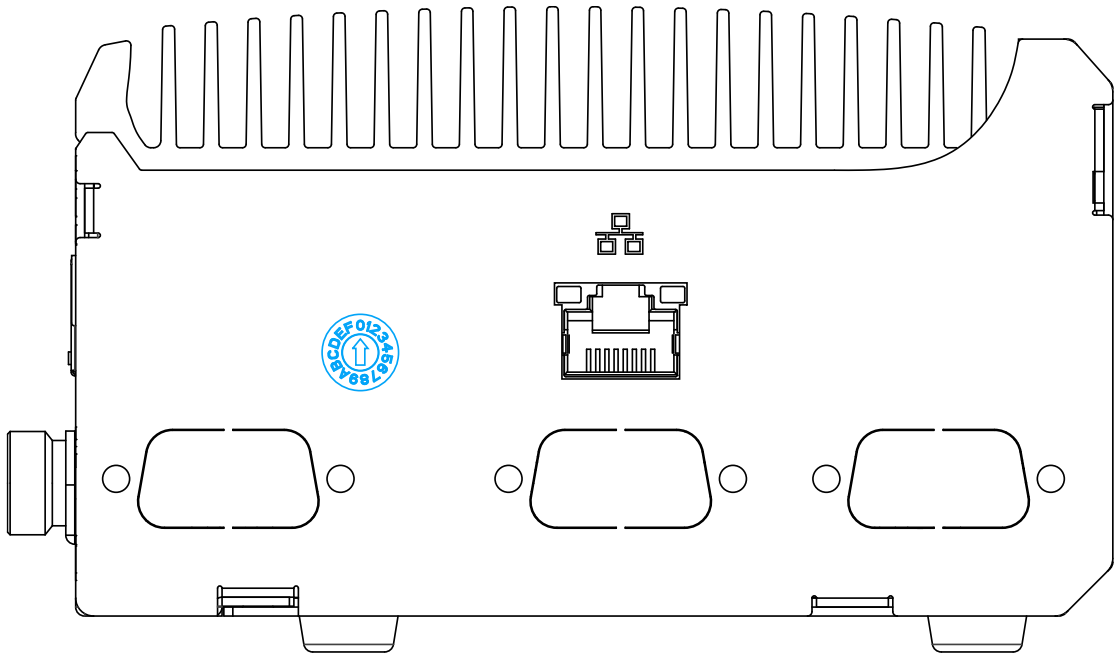

You can use the rotary switch to configure the operation mode. The system offers 16 (0~15) operation modes with different power-on/power-off delay configurations.

2.5.2 2.5Gb Ethernet Port

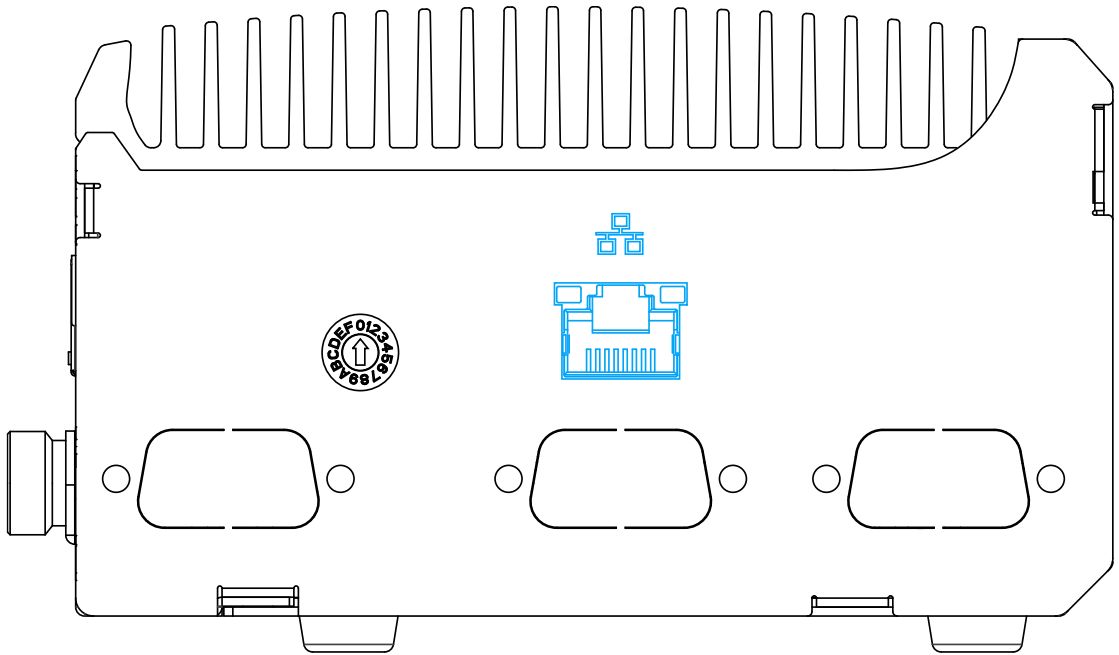

The system has a 2.5Gb Ethernet port by Intel® I226-IT for data logging and transmission. Please refer to the table below for LED connection statuses.

Active/Link LED

LED Color	Status	Description
Orange	Off	Ethernet port is disconnected
	On	Ethernet port is connected and no data transmission
	Flashing	Ethernet port is connected and data is transmitting/receiving

Speed LED

LED Color	Status	Description
Red or Green	Off	10 Mbps
	Green	100 Mbps
	Red	1000/ 2500 Mbps

To utilize the Ethernet port in Windows, you need to install corresponding driver for the Ethernet controller.

2.6 Internal I/O

The system's internal I/O connectors consist of a mini-PCIe slot with SIM slot, an M.2 slot for NVMe SSD, and SO-DIMM socket.

2.6.1 Full-size mini-PCIe with SIM Slot on Motherboard

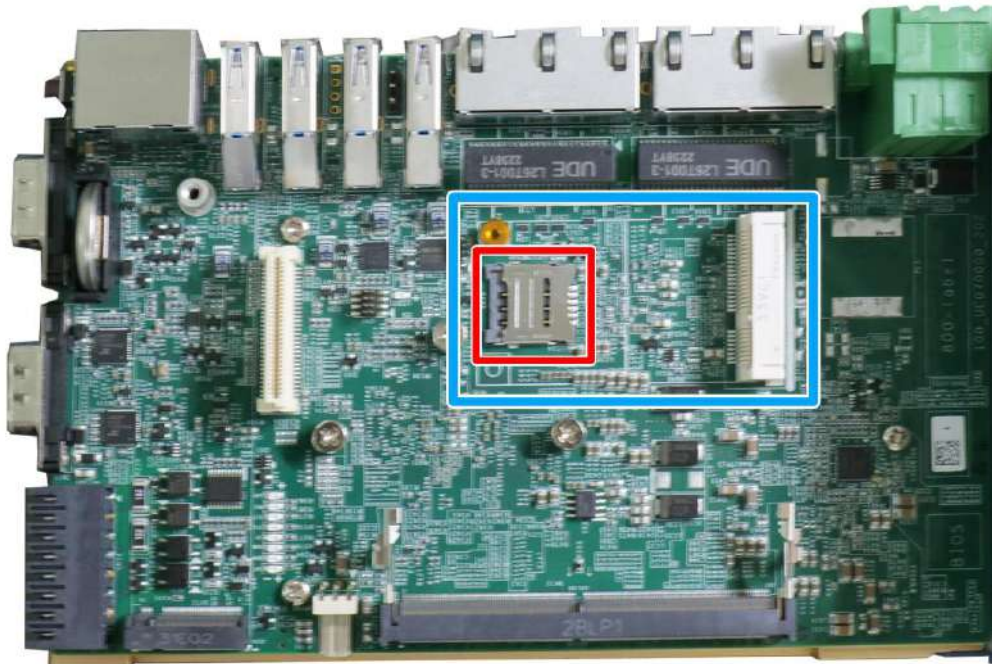

The system provides a full-size mini-PCIe socket (indicated in blue) designed with SIM card (indicated in red) support. With a SIM card installed, your system can access the internet via your network provider's 3G/ 4G network.

For wireless (WIFI/ 3G/ 4G) communication, there are SMA antenna openings on system side panels.

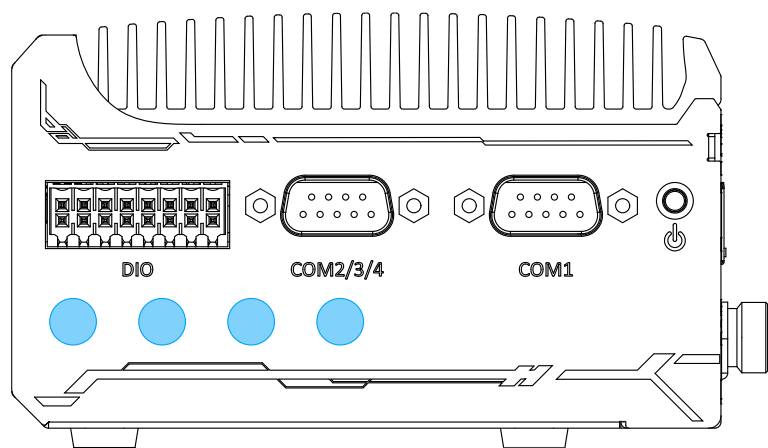

DIO/ COM port panel antenna openings

mini-PCIe Pin Definition

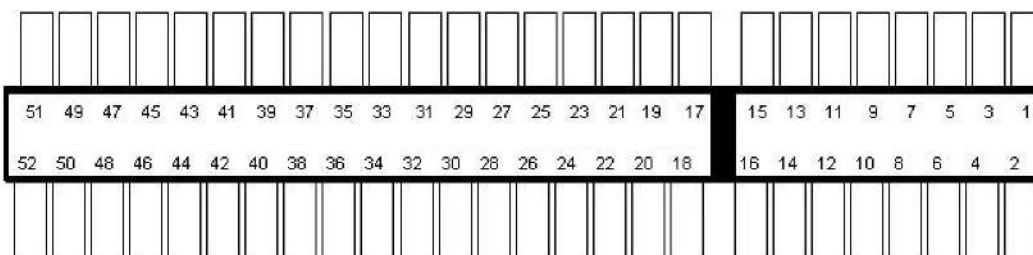

Pin #	Signal	Pin #	Signal
1	WAKE#	2	+3.3Vaux
3	COEX1	4	GND
5	COEX2	6	+1.5V
7	CLKREQ#	8	UIM_PWR
9	GND	10	UIM_DATA
11	REFCLK-	12	UIM_CLK
13	REFCLK+	14	UIM_RESET
15	GND	16	UIM_VPP
Mechanical Key			
17	Reserved* (UIM_C8)	18	GND
19	Reserved* (UIM_C4)	20	W_DISABLE#
21	GND	22	PERST#
23	PERn0	24	+3.3Vaux
25	PERp0	26	GND
27	GND	28	+1.5V
29	GND	30	SMB_CLK
31	PETn0	32	SMB_DATA
33	PETp0	34	GND
35	GND	36	USB_D-
37	GND	38	USB_D+
39	+3.3Vaux	40	GND
41	+3.3Vaux	42	LED_WWAN#
43	GND	44	LED_WLAN#
45	Reserved	46	LED_WPAN#
47	Reserved	48	+1.5V
49	Reserved	50	GND
51	Reserved	52	+3.3Vaux



WARNING

Some off-the-shelf mini-PCIe 4G modules use 1.8V I/O signals instead of 3.3V I/O and may cause signal interference. Installing an incompatible 4G module may damage the system or the module itself may be damaged. Please consult with Neusys when in doubt!

2.6.2 Full-sized mini-PCle on MeziO

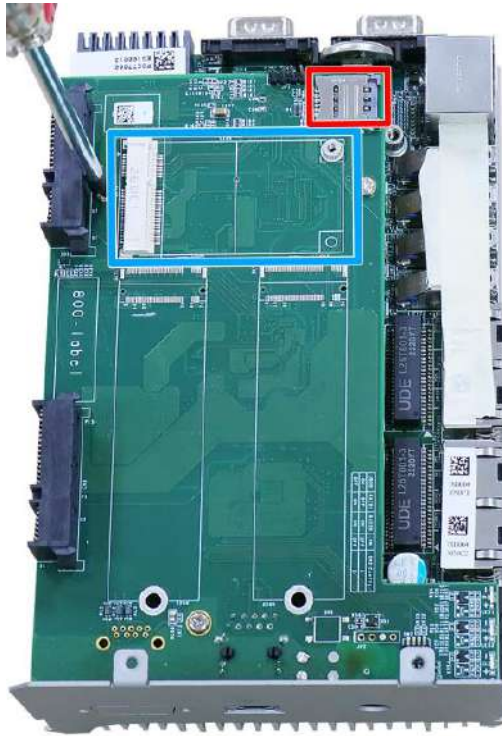

The system provides a full-size mini-PCle socket (indicated in **blue**) to install a WiFi module for wireless communications. The SIM card slot is indicated in **red**, and when installed, your system can access network provider's 4G/ 3G wireless network.

For wireless WiFi communication, there are SMA antenna openings on system side panels.

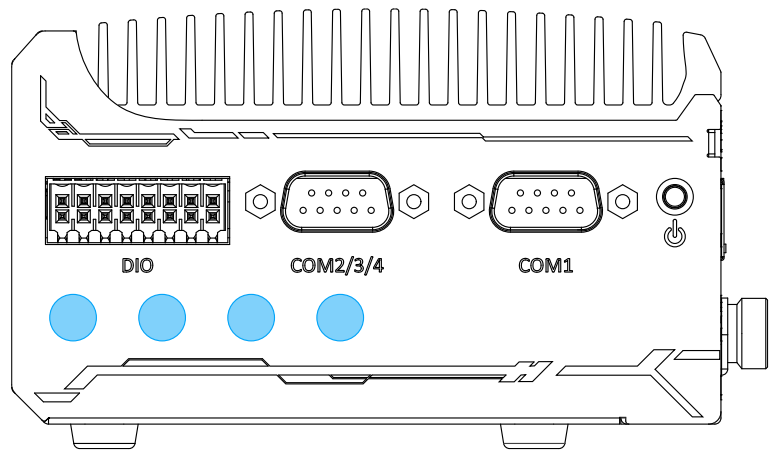

DIO/ COM port panel antenna openings

mini-PCle Pin Definition

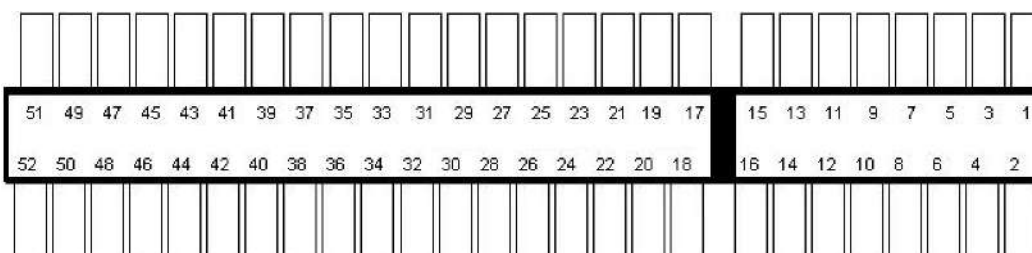

Pin #	Signal	Pin #	Signal
1	WAKE#	2	+3.3Vaux
3	COEX1	4	GND
5	COEX2	6	+1.5V
7	CLKREQ#	8	UIM_PWR
9	GND	10	UIM_DATA
11	REFCLK-	12	UIM_CLK
13	REFCLK+	14	UIM_RESET
15	GND	16	UIM_VPP
Mechanical Key			
17	Reserved* (UIM_C8)	18	GND
19	Reserved* (UIM_C4)	20	W_DISABLE#
21	GND	22	PERST#
23	PERn0	24	+3.3Vaux
25	PERp0	26	GND
27	GND	28	+1.5V
29	GND	30	SMB_CLK
31	PETn0	32	SMB_DATA
33	PETp0	34	GND
35	GND	36	USB_D-
37	GND	38	USB_D+
39	+3.3Vaux	40	GND
41	+3.3Vaux	42	LED_WWAN#
43	GND	44	LED_WLAN#
45	Reserved	46	LED_WPAN#
47	Reserved	48	+1.5V
49	Reserved	50	GND
51	Reserved	52	+3.3Vaux



WARNING

Some off-the-shelf mini-PCle 4G modules use 1.8V I/O signals instead of 3.3V I/O and may cause signal interference. Installing an incompatible 4G module may damage the system or the module itself may be damaged. Please consult with Neusys when in doubt!

2.6.3 M.2 2280 (M Key) Slot for SSD

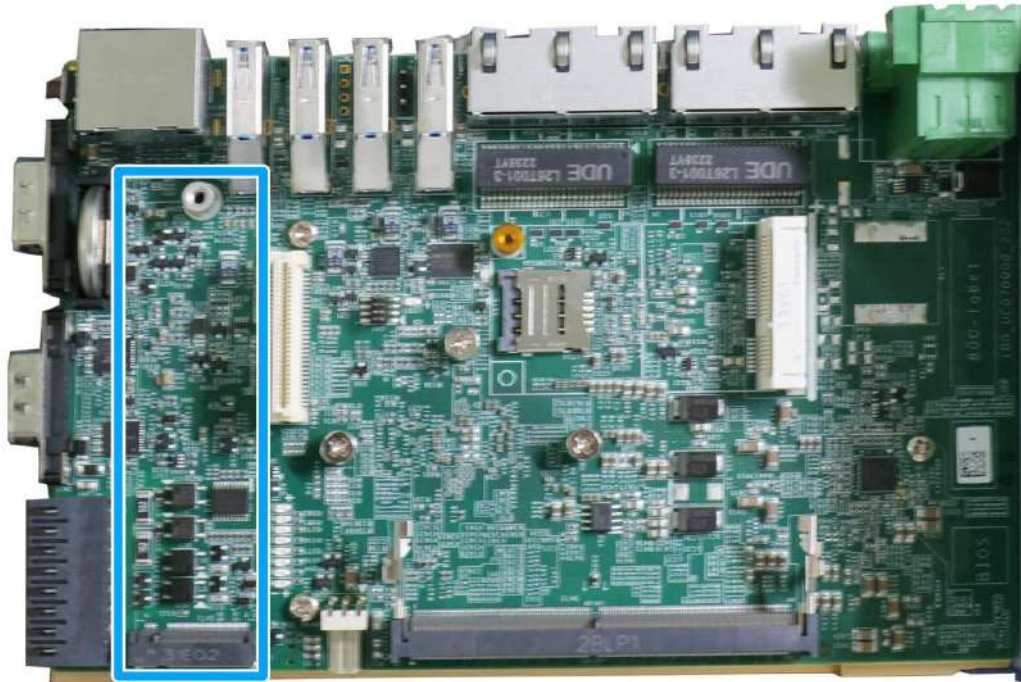

The system has an M key M.2 2280 slot supporting PCIe Gen3 x1 signal for NVMe SSD storage, and it also supports SATA signal for SATA SSD. Users can install an SSD for improved disk read/ write performance over mechanical hard drives or 2.5" SSDs.

**NOTE**

The M.2 slot will automatically detect and configure the slot to run PCIe or SATA signal depending on the installed device.

M.2 (M Key) Slot Pin Definition

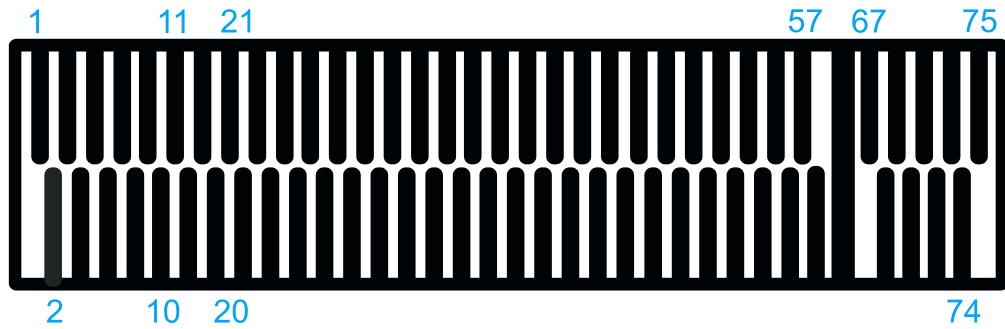

Pin #	Signal	Pin #	Signal
1	GND	2	+3V3
3	GND	4	+3V3
5	PERN3	6	-
7	PERP3	8	-
9	GND	10	DAS/DSS N
11	PETN3	12	+3V3
13	PETP3	14	+3V3
15	GND	16	+3V3
17	PERN2	18	+3V3
19	PERP2	20	-
21	GND	22	-
23	PETN2	24	-
25	PETP2	26	-
27	GND	28	-
29	PERN1	30	-
31	PERP1	32	-
33	GND	34	-
35	PETN1	36	-
37	PETP1	38	-
39	GND	40	-
41	PERn0 / SATA-B+	42	-
43	PERp0 / SATA-B-	44	-
45	GND	46	-
47	PETn0 / SATA-A-	48	-
49	PETp0 / SATA-A+	50	PERST N
51	GND	52	CLKREQ
53	REFCLKN	54	-
55	REFCLKP	56	-
57	GND	58	-
Mechanical Key			
67	-	68	SUSCLK
69	PEDET	70	+3V3
71	GND	72	+3V3
73	GND	74	+3V3
75	GND		

2.6.4 SO-DIMM Socket

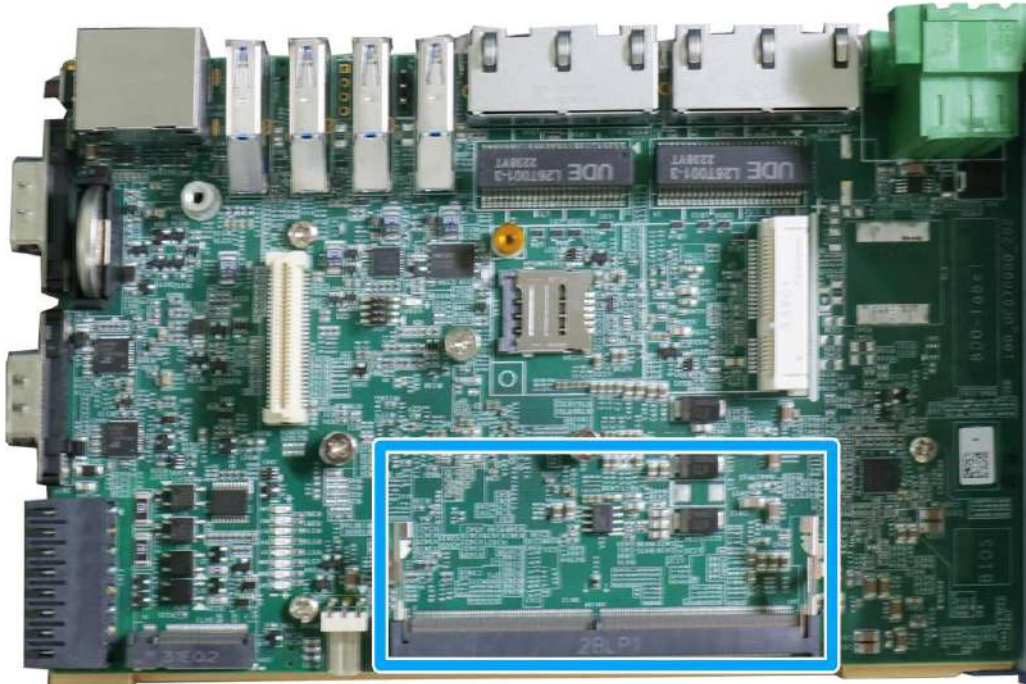

The system supports one SO-DIMM socket for installing DDR5-4800 memory module up to 16GB in capacity.

2.6.5 DIP Switch

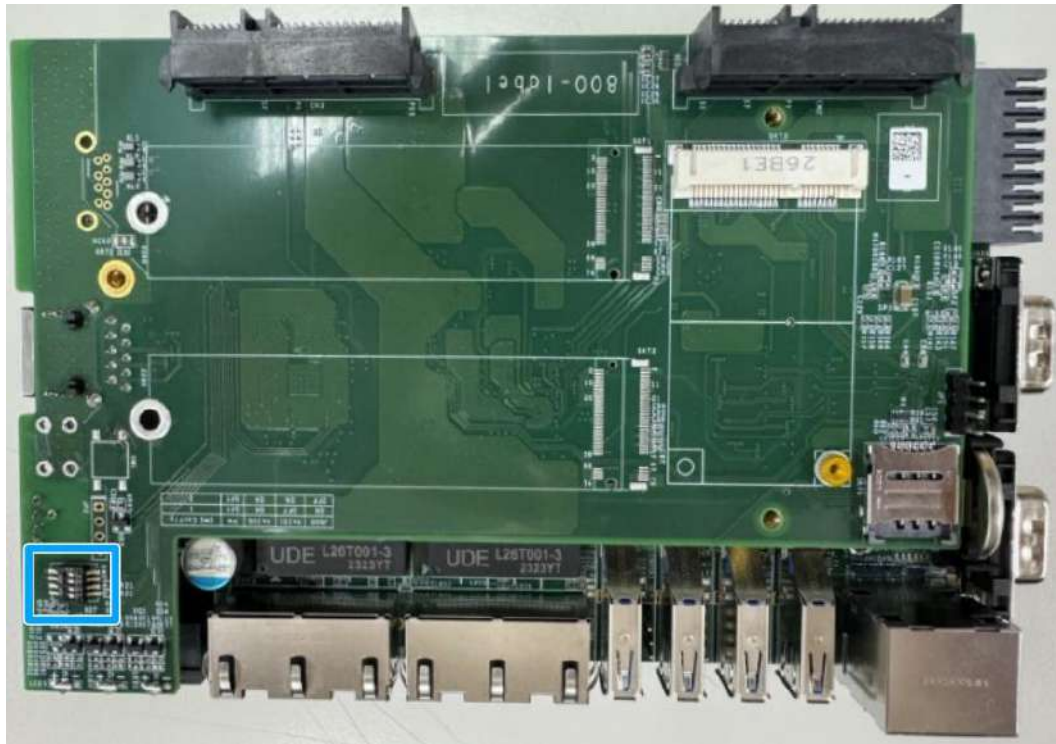

The first two dip switches' configuration determines the SATA port modes: Port Multiplier (PM), RAID-0, RAID-1 (Default), and JBOD.

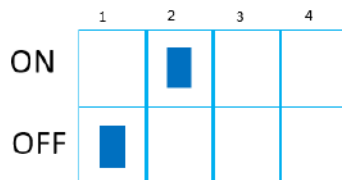

The dip switch settings are as follows:

Dip switch \ Mode	Port multiplier (PM)	RAID-0	RAID-1 (Default)	JBOD
1	Off	On	Off	On
2	Off	On	On	Off

3 System Installation

Before disassembling the system enclosure and installing components and modules, please make sure you have done the following:

- It is recommended that only qualified service personnel should install and service this product to avoid injury or damage to the system.
- Please observe all ESD procedures at all times to avoid damaging the equipment.
- Before disassembling your system, please make sure you have the module/ component you wish to install at hand and have all the necessary tools.
- Before disassembling your system, please make sure the system has powered off, all cables and antenna (power, video, data, etc.) are disconnected.
- Place the system on a flat and sturdy surface (remove from mounts or out of server cabinets) before proceeding with the installation/ replacement procedure.

3.1 Disassembling the System Enclosure

To install internal components such as M.2 SSD, memory module, or mini-PCIe module, you need to disassemble the system enclosure. Please refer to the following procedures:

1. Remove the three (3) screws on the front I/O panel.



2. Remove the three (3) screws.



3. Remove the two (2) screws on the rear panel.



4. Remove the four (4) hex bolt screws on the DIO/ COM port panel.



5. Separate the IO and bottom panel from the system



Remove front IO panel



Remove bottom panel

6. Remove the screws securing the MeziO module, and separate it from the motherboard.

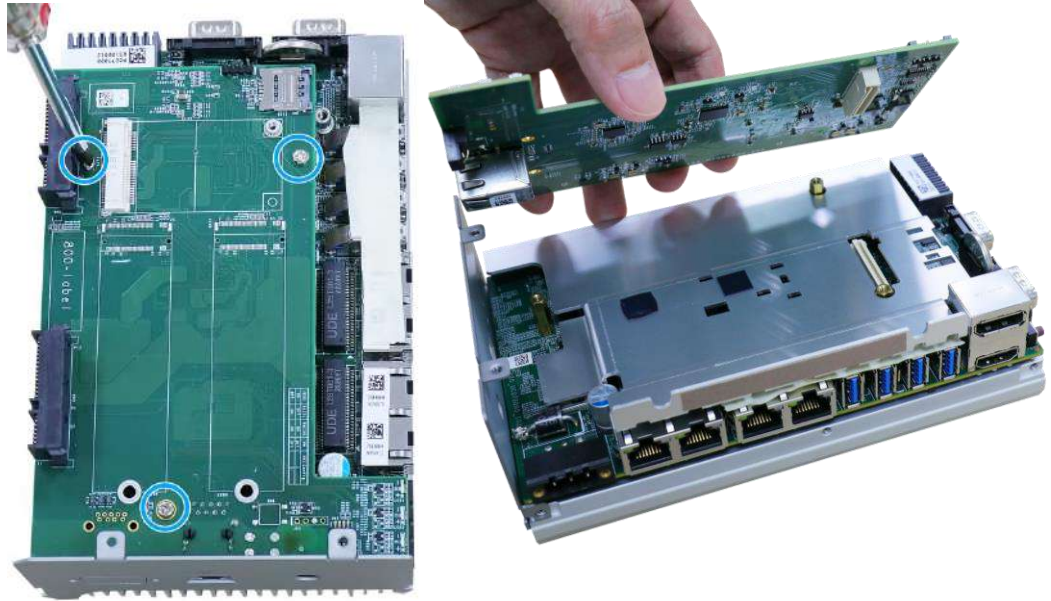

Remove screws securing the MeziO module

Separate MeziO module from motherboard

7. Remove the screws securing the DRAM/ M.2 heat spreader, and separate it from the motherboard/ heatsink.



Remove screws securing heat spreader

Separate the heat spreader

8. With external panels and DRAM/ M.2 heat spreader removed, you are ready to install internal components.
9. [Reinstall the enclosure](#) when done.

3.2 Installing Internal Components

3.2.1 DDR5 SO-DIMM Installation

There is one SO-DIMM memory slot on the motherboard. Please follow the procedures below to install the memory module.

1. [Disassemble the system enclosure.](#)
2. Locate the SO-DIMM slot on the motherboard shown once the enclosure and heat spreader have been removed.

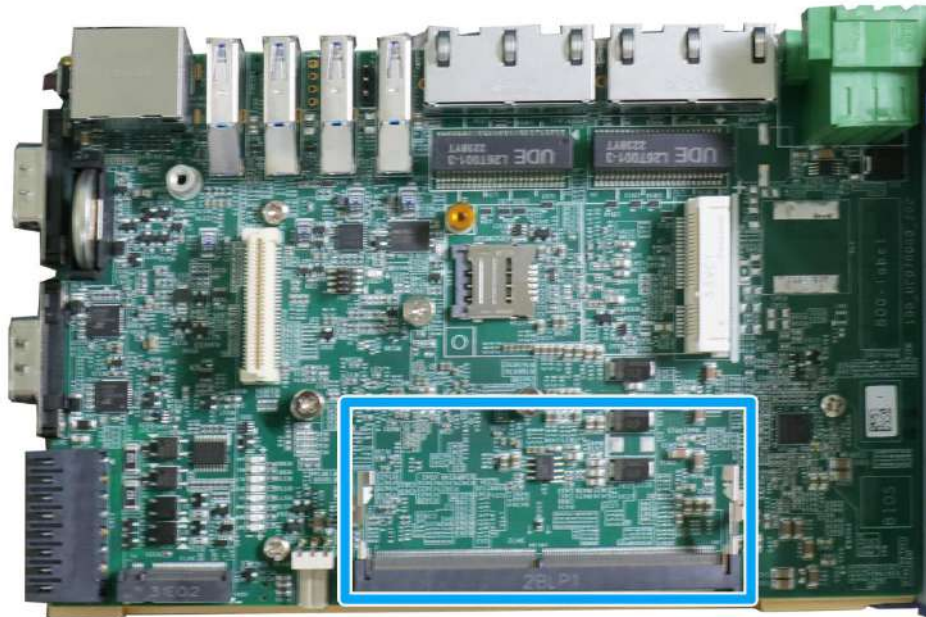

3. **To install**, insert the gold finger end of the SO-DIMM on a 45° angle into the slot and gently push the SO-DIMM down until it is clipped-in.

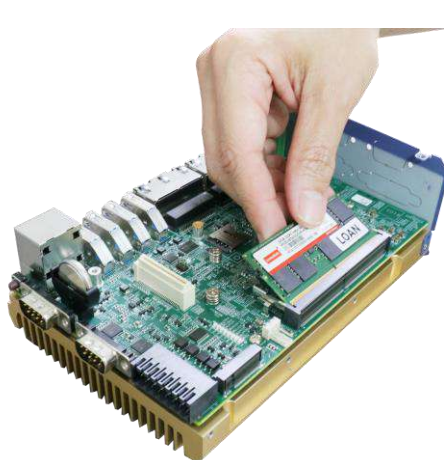

45° angle insert

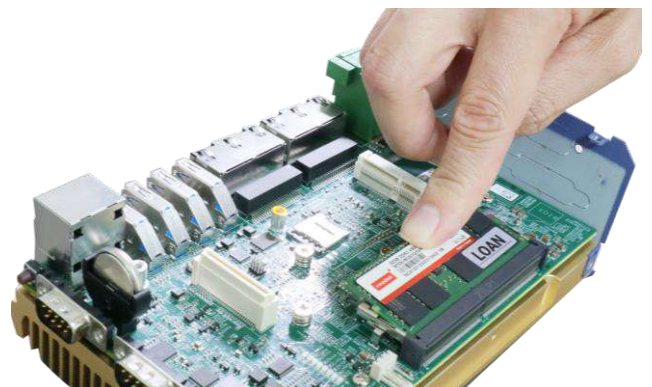

Push until it is clipped-in

4. Remove the protection film on the thermal pad.

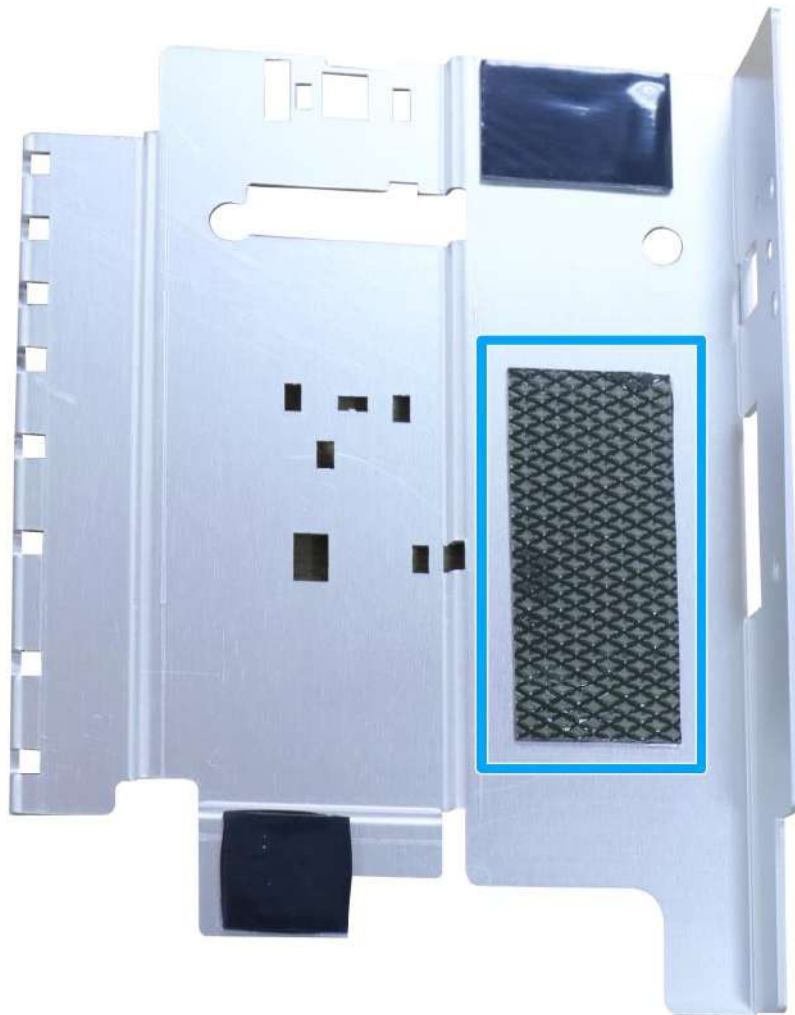

5. Secure the DRAM/ M.2 heatsink spreader onto the side of the system heatsink.



6. [Reinstall the enclosure](#) when done.

3.2.2 M.2 2280 M Key SSD Installation

There is one M.2 2280 M Key slot for you to install an SSD. Please follow the procedures below to install the M.2 SSD module.

1. [Disassemble the system enclosure.](#)
2. Located the M.2 2280 M Key slot once the system enclosure and heat spreader have been removed.

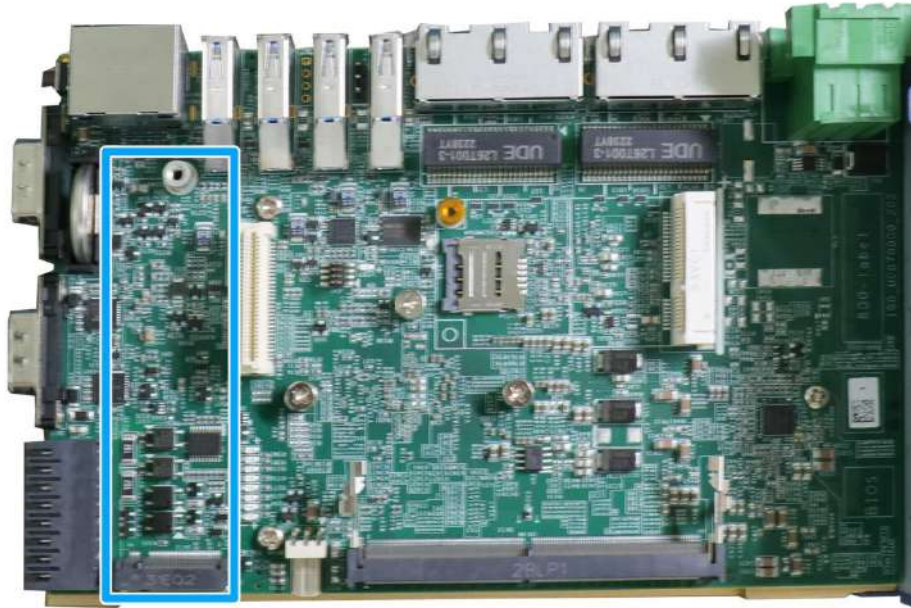

3. Insert the M.2 SSD into the slot on a 45° angle.

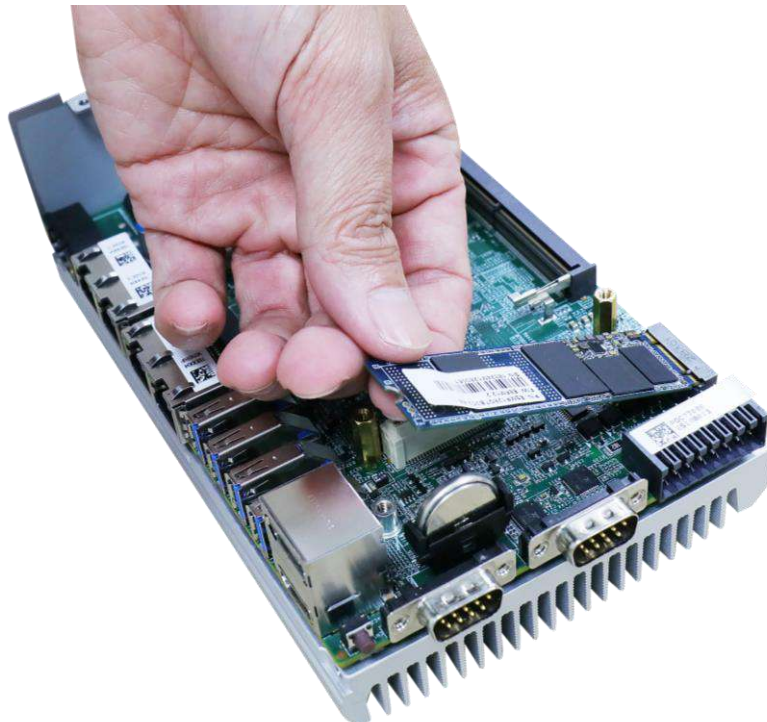

4. Gently push it towards the motherboard and secure the NVMe SSD with the supplied screw.



5. Once you have installed the NVMe SSD, you need to reinstall the heat spreader but before you do so, please make sure the protective film on the thermal pad has been removed.

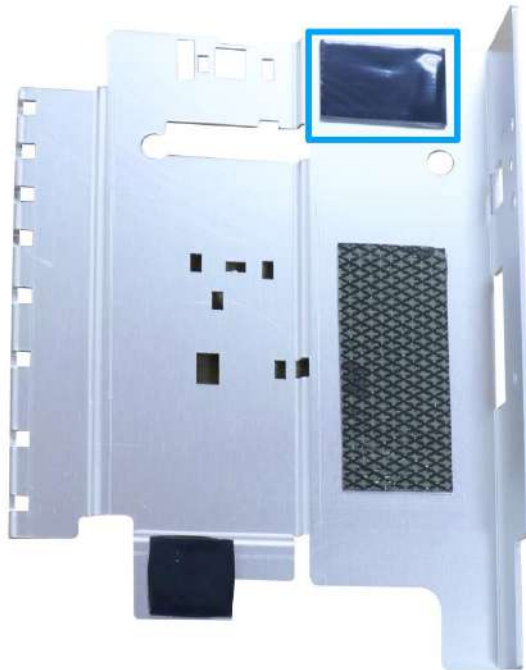

6. Secure the heat spreader by securing the two screws (indicated in red).



7. [Reinstall the enclosure](#) when done.

3.2.3 mini-PCle Module, SIM Card and Antenna Installation

There are mini-PCle with SIM slots on MezIO™ module and the motherboard. Please follow the procedures below to install the mini-PCle module and SIM card, as well as the antenna for wireless communication.

1. [Disassemble the system enclosure.](#)
2. The mini-PCle and SIM slots are shown in the illustration below.

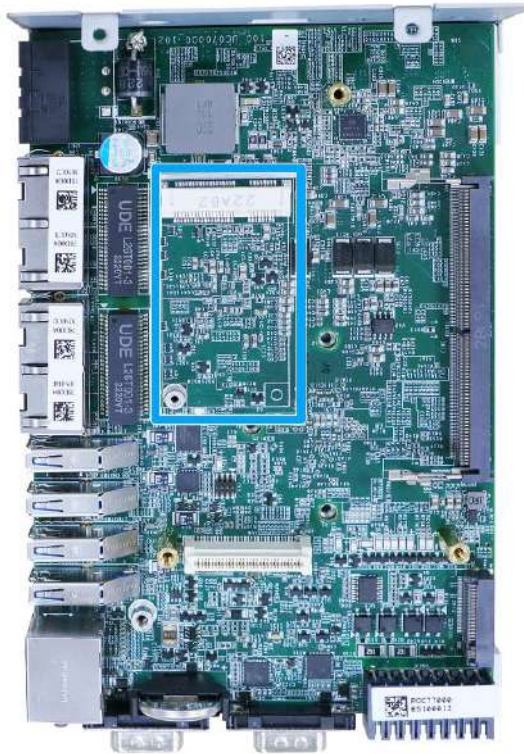

mPCle on motherboard



mPCle with SIM on MezIO module

3. If you are installing a 4G/ 3G wireless module that requires a SIM, please install the SIM card first. Otherwise go to the next step. Push the SIM slot holder in the direction shown and flip open the holder to place the SIM into the slot.

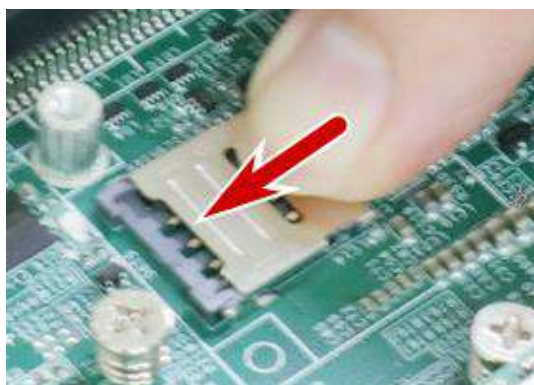

Push the SIM holder in the direction shown



Flip open the holder and place SIM

4. Flip the holder back onto the SIM card and push in the direction shown to lock-in the SIM card into the slot.

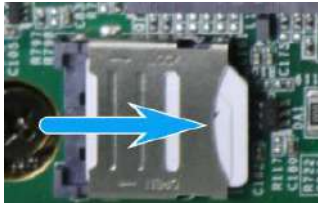

5. **To install**, insert mini-PCIe module's gold finger on a 45° angle into the socket, gently press the module down and secure it with a screw.



Insert on a 45° angle



Secure the module with a screw

6. Clip-on mini-PCIe module's antenna (please refer to the module's user manual on antenna cable connection).

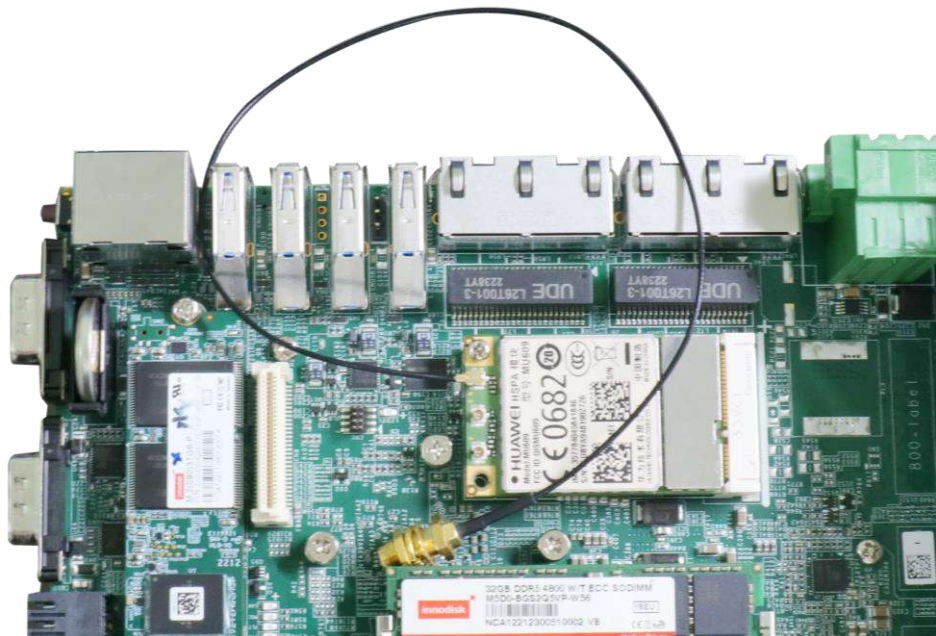

7. Remove one of the antenna covers from the enclosure.

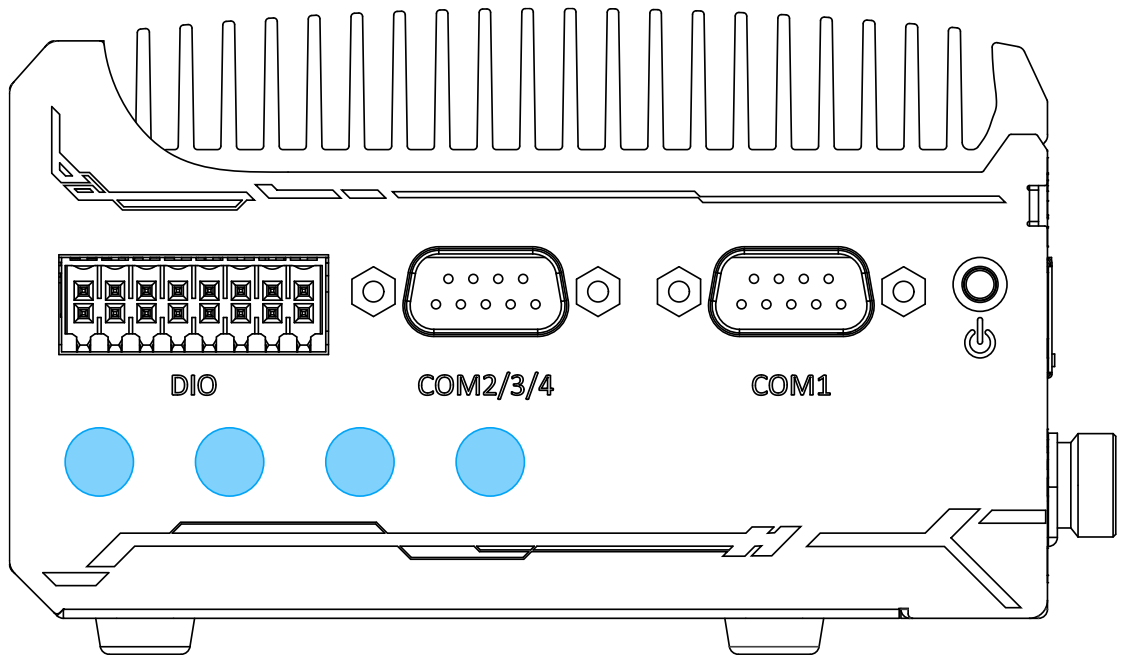

8. Secure the SMA antenna connector, [reinstall the enclosure](#) and attach the external SMA antenna.

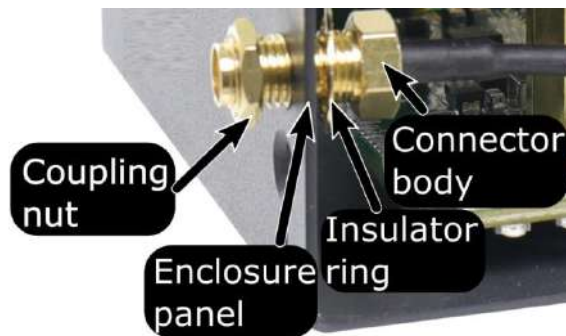

Securing antenna connection



Attach external antenna

9. [Reinstall the enclosure](#) when done.

3.3 Installing the System Enclosure

1. Place and secure the heat spreader back onto the motherboard if you haven't done so.

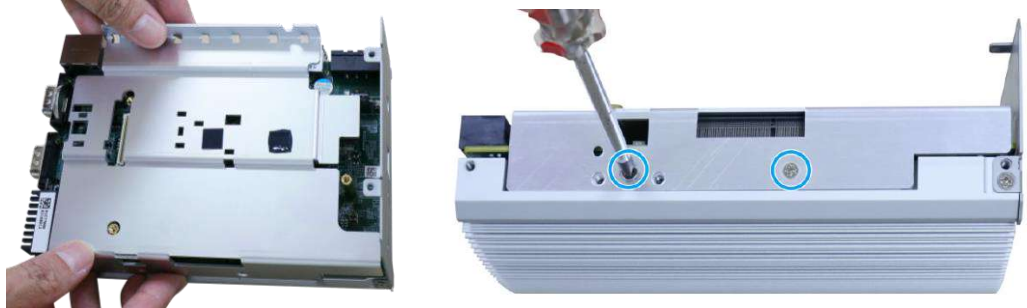

Place and secure the heat spreader

2. Place and secure the MezIO module back on the motherboard.

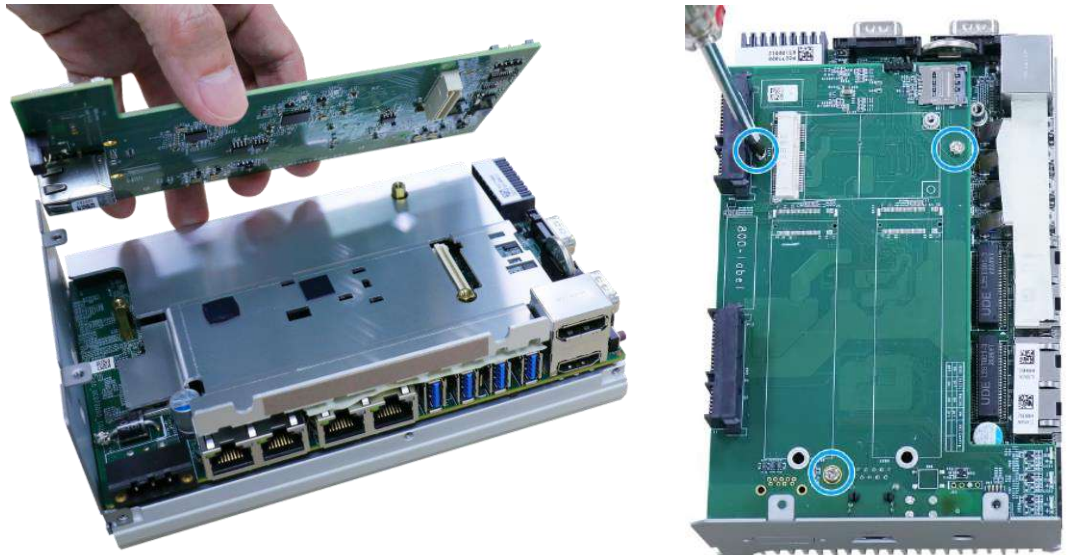

Place and secure the MezIO module

3. Install the bottom/ rear enclosure panel



4. Install the front panel and securing it with three (3) screws.



Install front panel

Secure with screws

5. Secure the bottom and rear panel with screws.



Bottom panel screws



Rear panel screws

- Secure the hex bolt screws on the DIO/ COM port panel to complete the enclosure installation.



3.4 2.5" HDD/SSD Installation

The system features two 2.5" hard drive trays supporting disk drives up to 7.5mm thickness. When installing two drives, the system supports configurations in RAID 0 (stripping mode for performance) or RAID 1 (mirror mode for backup and redundancy). To install 2.5" drives, please refer to the instructions below.

1. Locate the 2.5" tray locations and their respective thumb screws (in red).

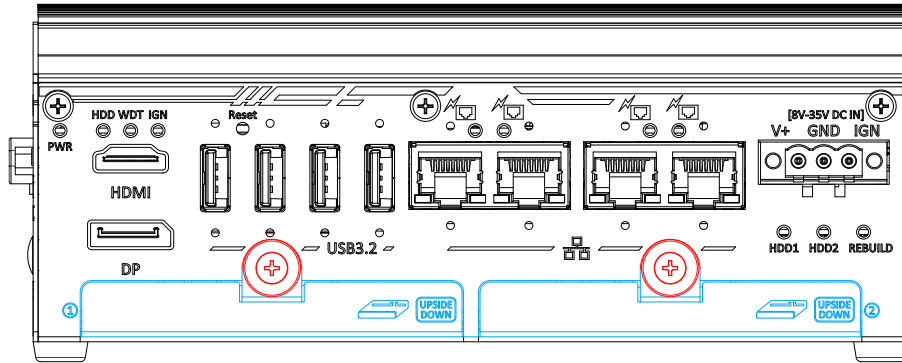

2. Turn the thumb screws anti-clockwise and retrieve the 2.5" tray out of the system I/O panel.



Turn thumb screw anti-clockwise



Retrieve tray out of I/O panel

3. With the disk drive placed in the orientation shown below, secure the disk drive with four flathead screws.



SATA connectors facing up and towards the system



Secure disk drive with two screws on each side

4. When inserting the installed tray with disk drive, hold and insert the tray on a leveled plain, and not on an angle.



Leveled plain insert



DO NOT insert on an angle

5. The reason for the leveled plain insertion is so that the tray can be properly secured under the hinges inside the enclosure.



6. Once inserted, secure the tray by turning the thumb screw clockwise.



7. If you are installing the second drive, please repeat the steps above.

3.5 DIN Rail Installation

The system comes with a DIN rail clip (in the accessory box) that allows the system to be mounted vertically.

1. To install, secure the DIN rail clip (indicated in **red**) to the rear side panel of the system enclosure using the M4 screws (indicated in **blue**) provided.

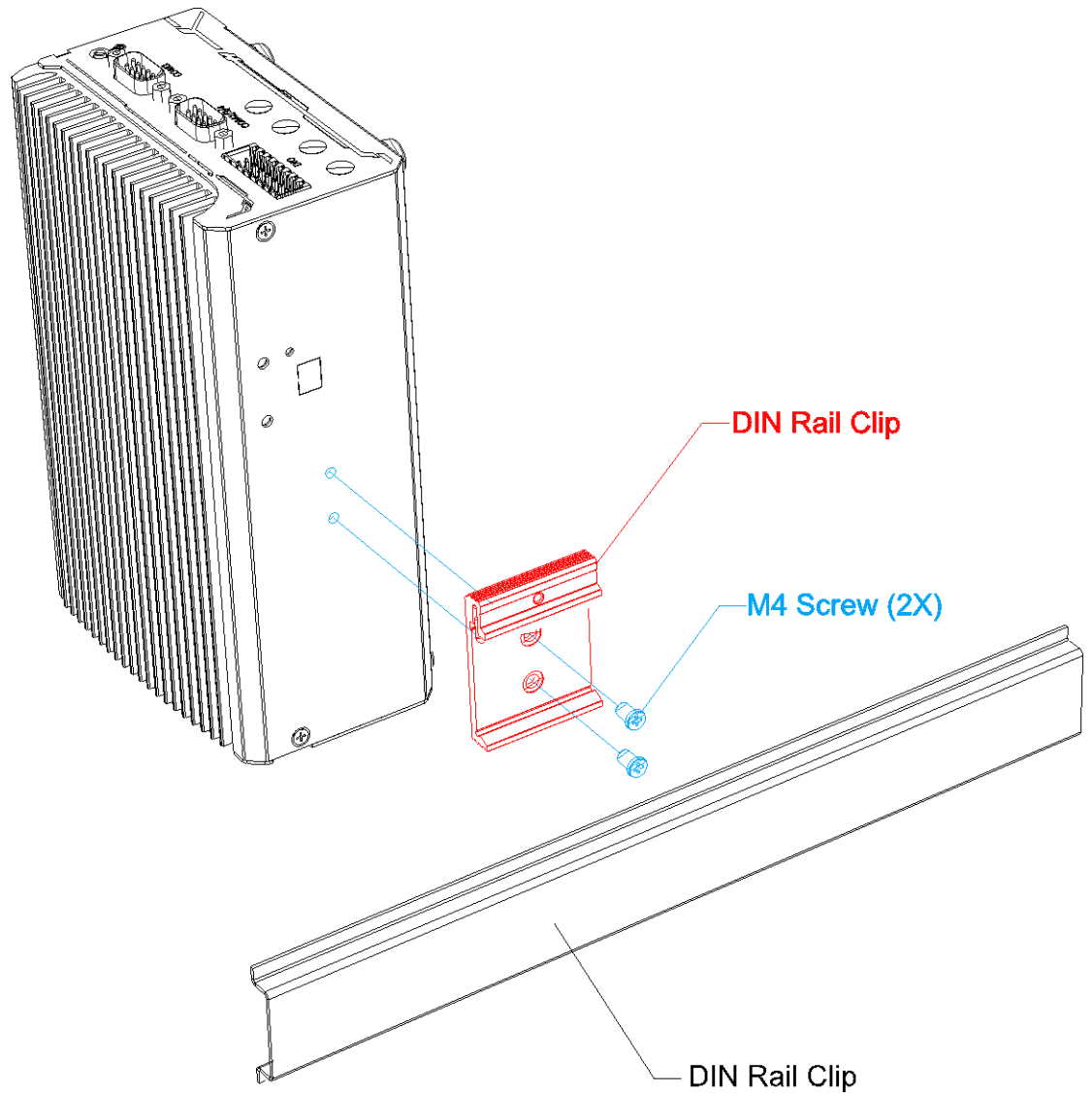

2. To install the DIN rail clip onto the DIN rail, you must come over the top of the DIN rail, tilting, overlap the top clip edge of the DIN rail clip onto the DIN rail first, and then firmly press the bottom-front of the enclosure to clip the bottom edge of the mount plate.

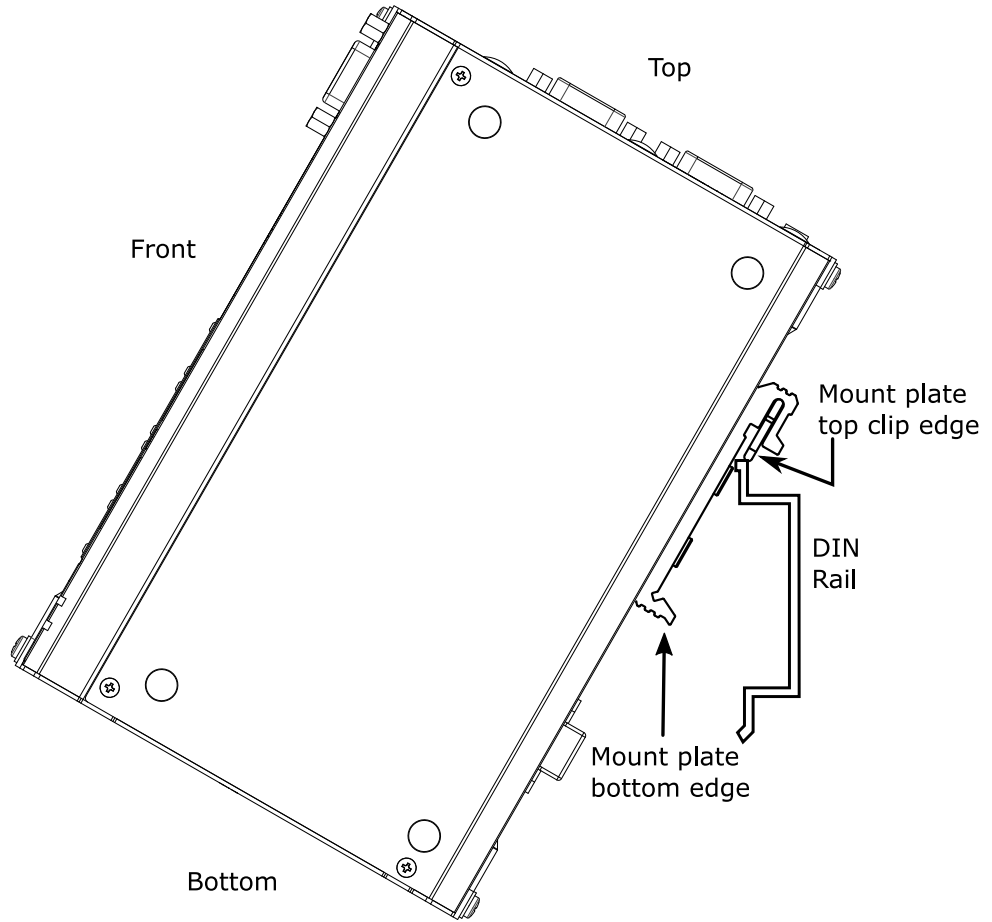

3. Confirm the mount plate has indeed clipped onto the DIN rail for proper fit to complete the installation.

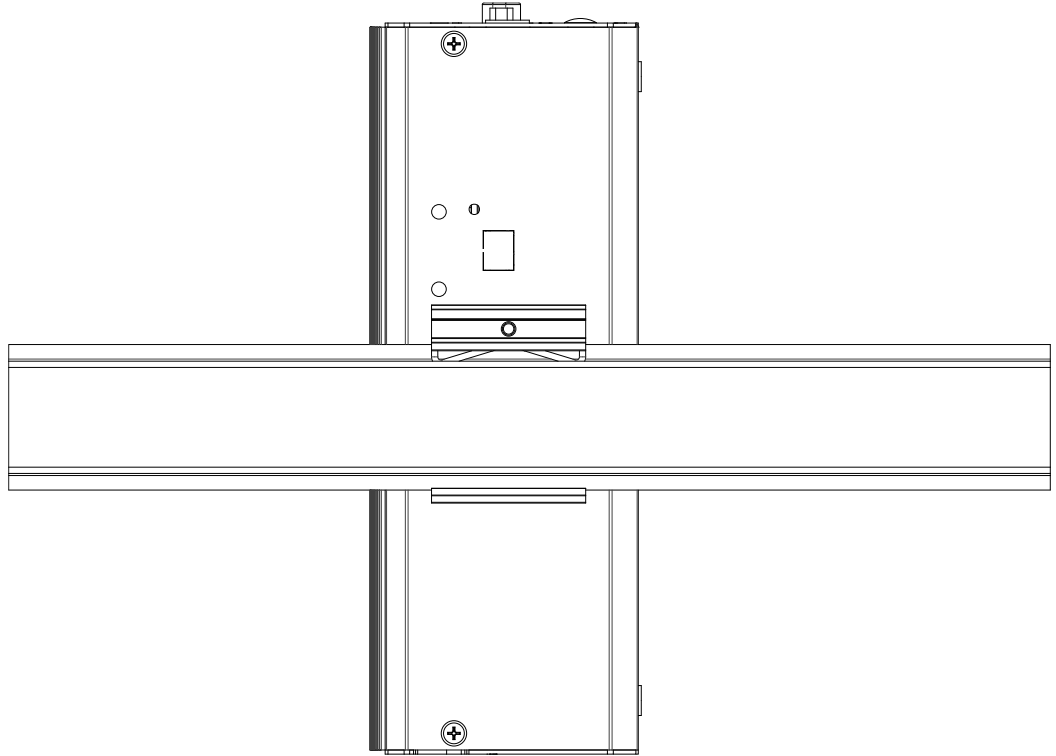

3.6 Horizontal Wall Mount Installation (Optional)

The optional horizontal wall mount bracket allows the system to be mounted horizontally. Please refer to the following installation procedure:

1. Remove the rubber stands to access the M4 tapping (indicated in **green**).

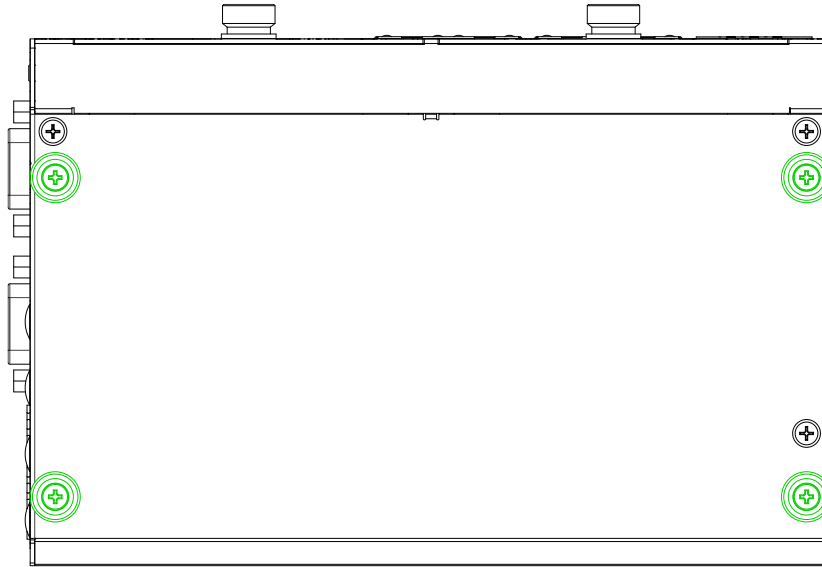

2. To install, secure the wall mount bracket (indicated in **red**) to the bottom of the system enclosure using the M4 screws (indicated in **blue**) provided.

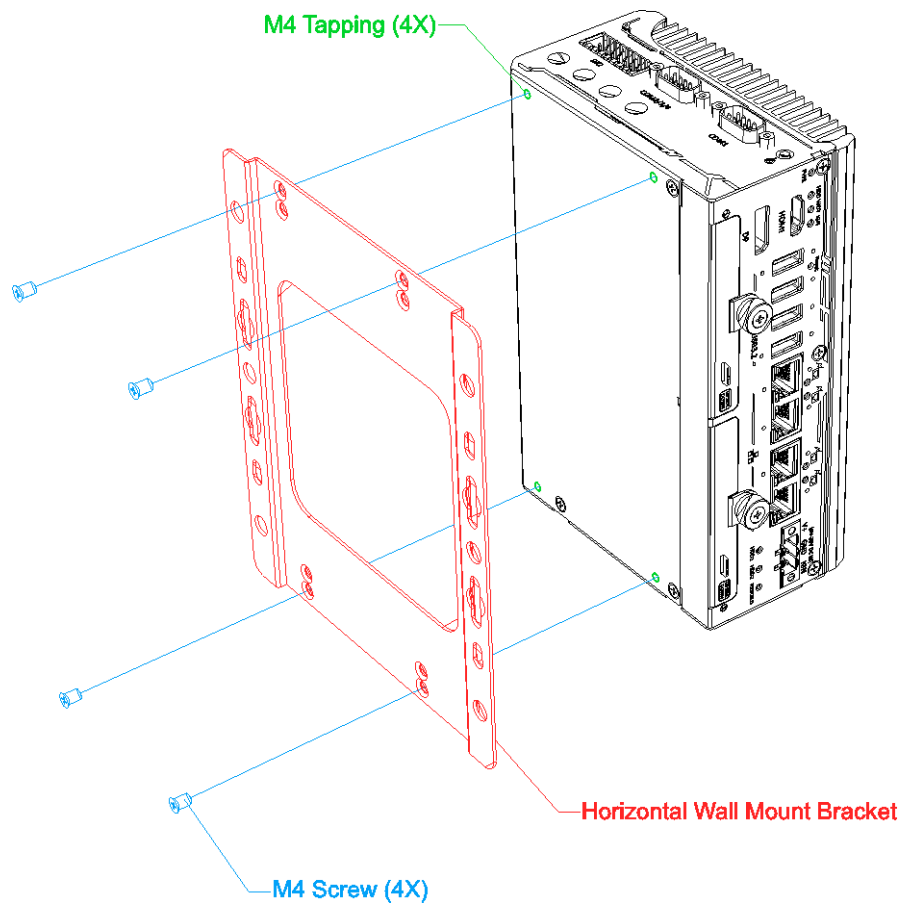

3. Dimension illustration of the installed horizontal wall mount bracket for your reference.

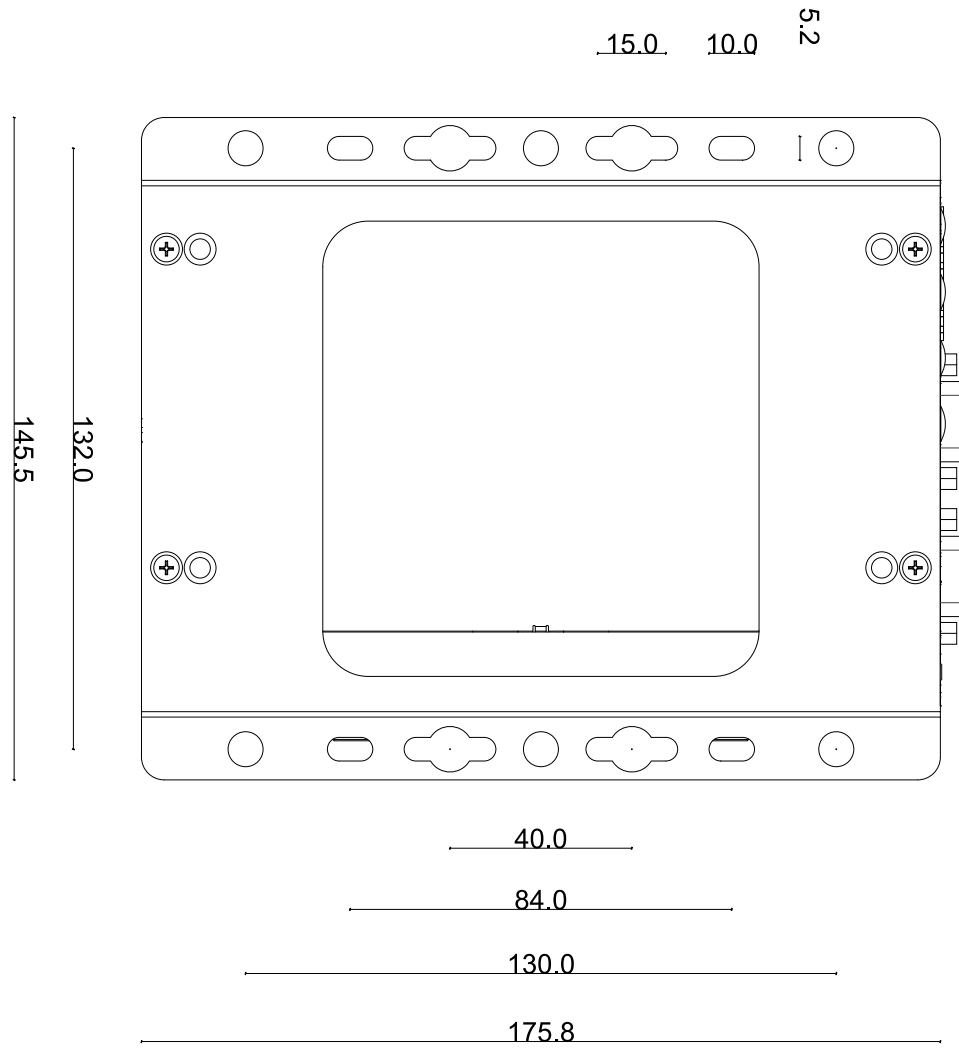

3.6.1 Vertical Wall Mount Bracket (Optional)

- To install, secure the vertical wall mount bracket (indicated in red) to the rear panel of the system using the M4 screws provided (indicated in blue).

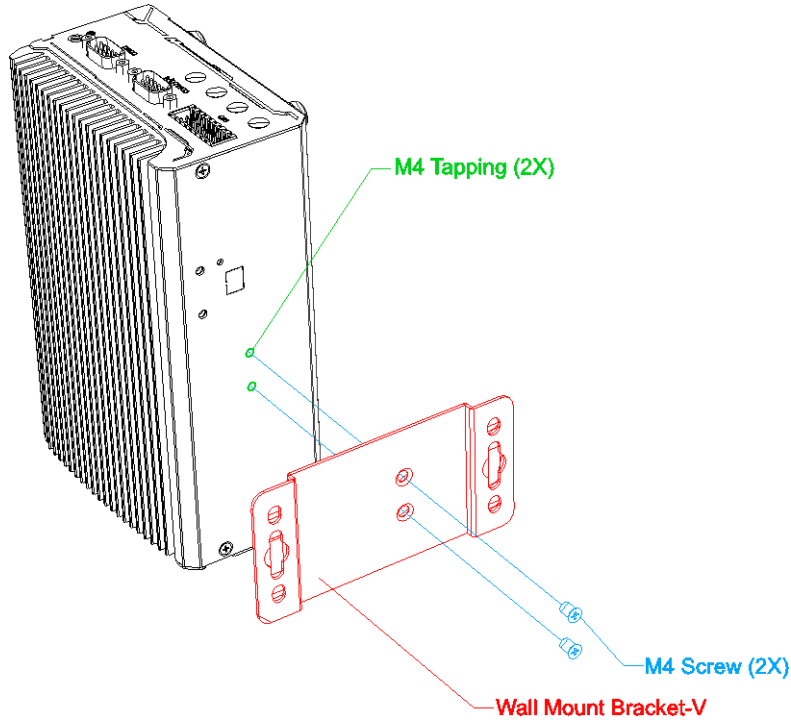

- Dimension illustration of the install vertical wall mount bracket for your reference.

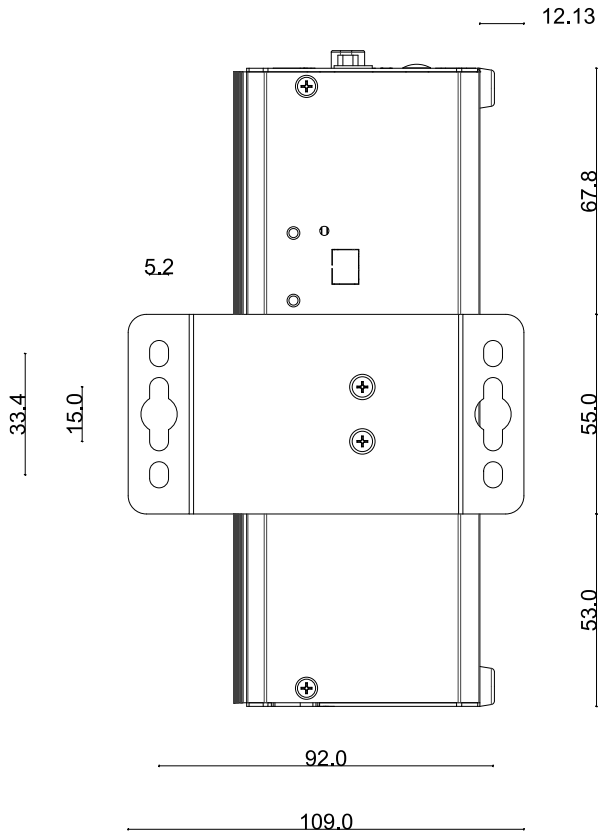

3.7 Fan Kit Installation (Optional)

The system comes with an optional fan kit for the system to operate in specific environments. To install the optional fan kit, please refer to the following procedure.

1. Place the fan on top of the system's heatsink and secure it with the screws (on front and rear panels) and beware of the orientation of the fan as the fan's power cable must within reach of the 4-pin fan power connector (on the rear panel).



NOTE

With front panel (the panel with DVI-I/ Ethernet/ USB, etc.) facing you, the fan's power connector should be on the left, just around the corner from USB ports.



Front panel screws



Rear panel screws

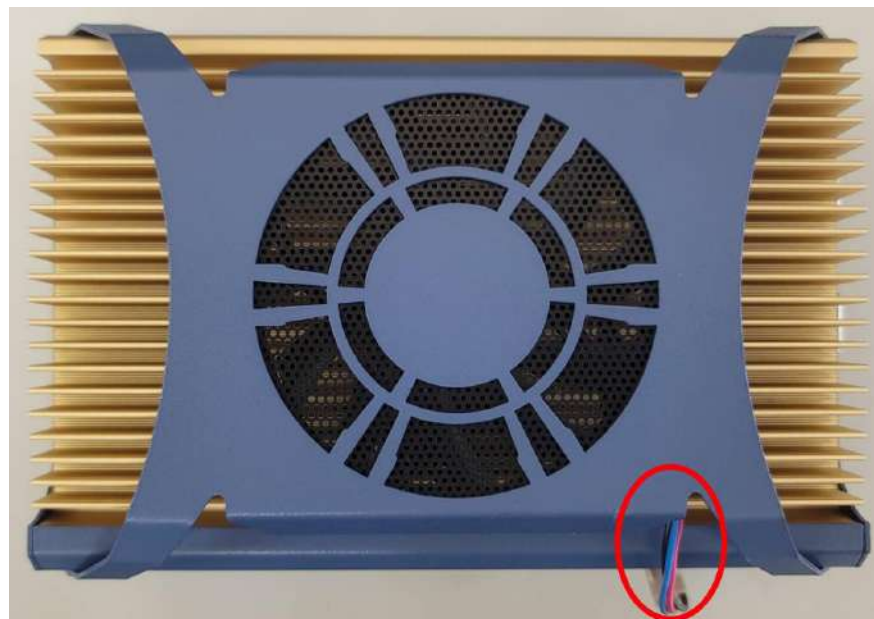

Orientation of fan's power cable must face the rear panel

2. Remove the punch-out panel, insert and connect the power cable.



Remove the punch-out panel

Insert and connect the fan's power cable

3. Once the power cable is connected, place the supplied cable cover over the power cable and secure it with screws indicated to complete the installation.

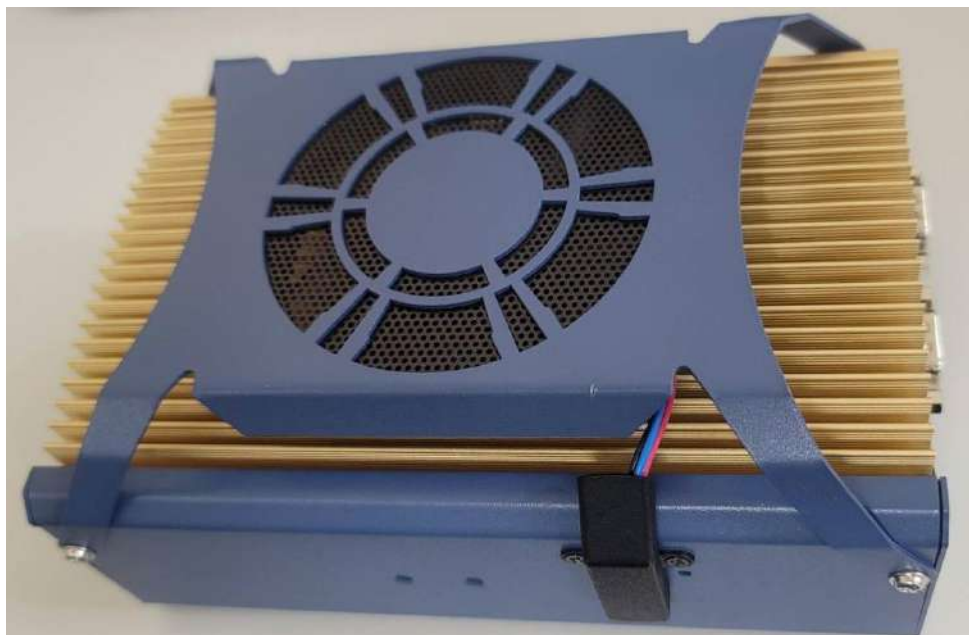
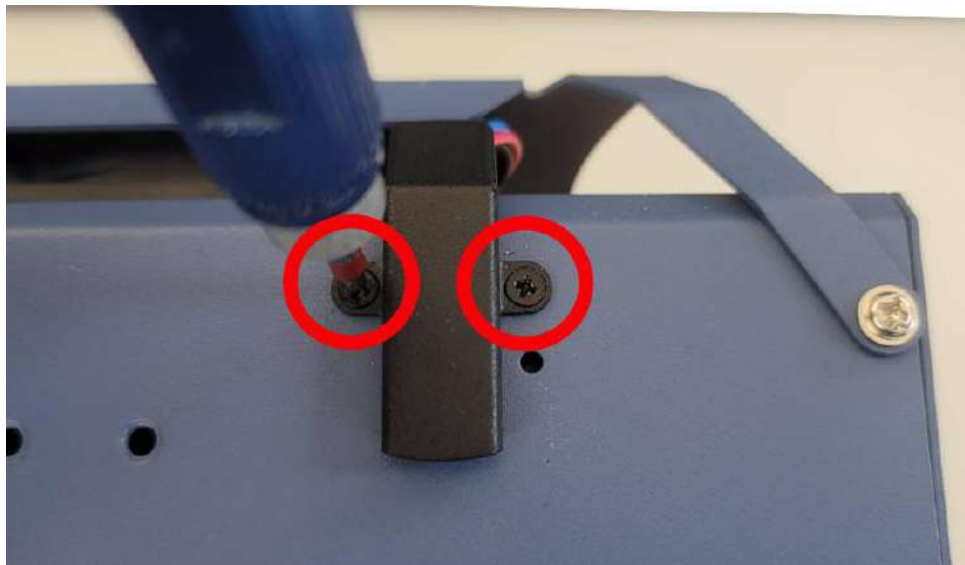

3.8 Powering On the System

There are three methods to power on the system

- [Pressing the power button](#)
- [Sending a LAN packet via Ethernet \(Wake-on-LAN\)](#)
- [Using the ignition power control signal input](#)

We will describe the processes and actions involved for the first four methods in this section. For powering on the system via the ignition signal input method, please refer to [Ignition Power Control](#).

3.8.1 Powering On Using the Power Button

This is the simplest way to turn on your system. The power button on the side panel is a non-latched switch and behaves as the ATX-mode on/off control. With DC power connected, pushing the power button will turn on the system and the PWR LED indicator will light up. Pushing the button when system is on will turn off the system. If your operating system supports ATX power mode (i.e. Microsoft Windows or Linux), pushing the power button while the system is in operation will result in a pre-defined system behavior, such as shutdown or hibernation.

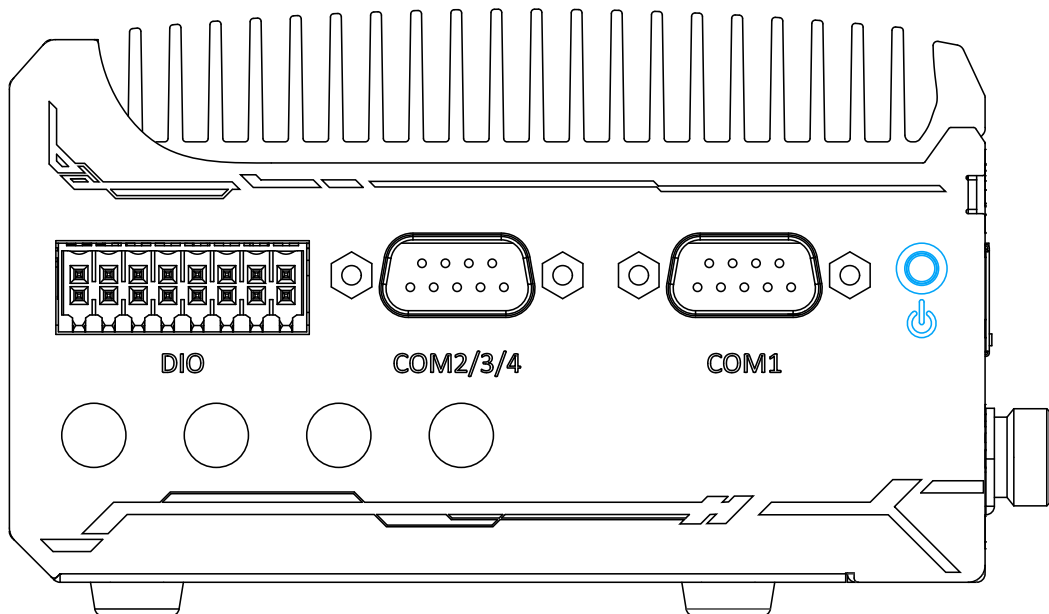

3.8.2 Powering On Using Wake-on-LAN

Wake-on-LAN (WOL) is a mechanism to wake up a computer system from a S3 (standby), S4 (Hibernate) or S5 (system off with standby power) state via issuing Subnet Directed Broadcasts (SDB) or a magic packet. The system implements the Wake-on-LAN function for the GbE ports highlighted in blue, shown below.

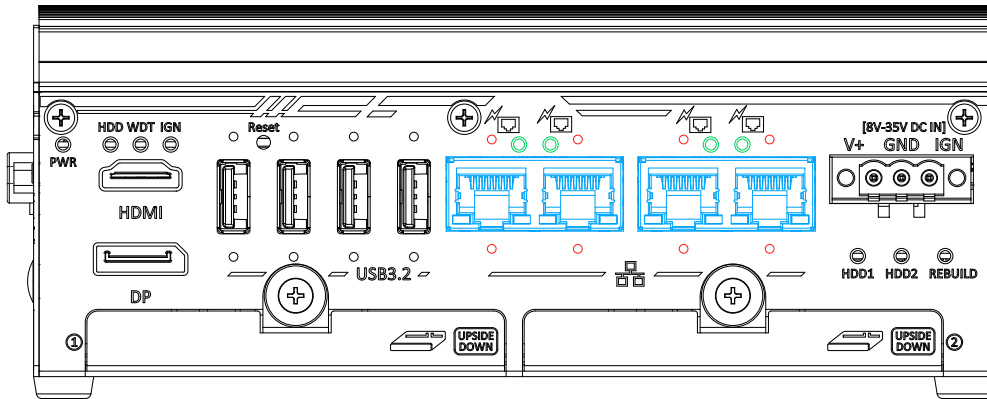

To enable WOL function and power on your system, please follow the steps below.

1. Press F2 when the system boots up to enter BIOS.
2. Enter the **[Power]** menu. And configure the **[Wake On LAN]** option as **[Enabled]**. Please refer to the [Wake-on-LAN](#) section.
3. In Windows systems, identify the Local Area Connection of the corresponding Gigabit Controller and click the **Configure** button.

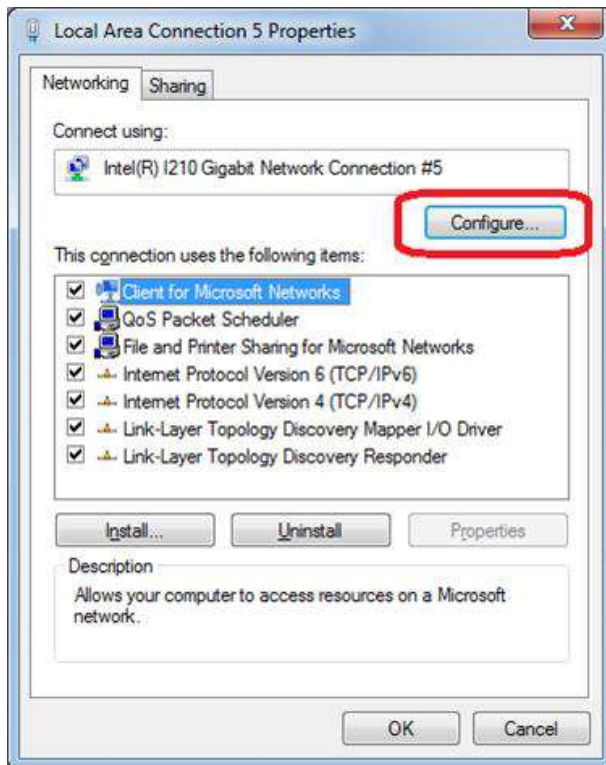

- Click the **Power Management** tag, and check the following two options accordingly

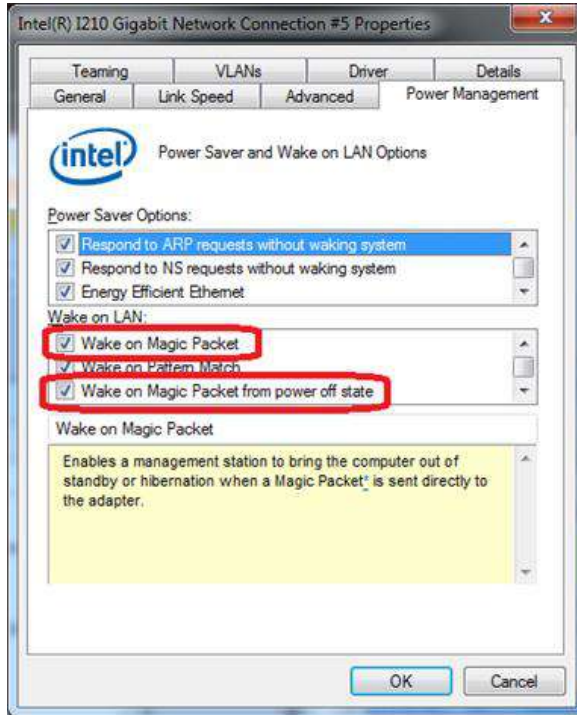

- **Wake on Magic Packet**

The system can wake from S3 or S4 state when receiving a magic packet. The magic packet is a broadcast frame containing anywhere within its payload 6 bytes of all 255 (FF FF FF FF FF FF in hexadecimal), followed by sixteen repetitions of the target computer's 48-bit MAC address.

For example, NIC's 48-bit MAC Address is 78h D0h 04h 0Ah 0Bh 0Ch

DESTINATION SOURCE MISC

FF FF FF FF FF FF

78 D0 04 0A 0B 0C 78 D0 04 0A 0B 0C

78 D0 04 0A 0B 0C 78 D0 04 0A 0B 0C

78 D0 04 0A 0B 0C 78 D0 04 0A 0B 0C

78 D0 04 0A 0B 0C 78 D0 04 0A 0B 0C

78 D0 04 0A 0B 0C 78 D0 04 0A 0B 0C

78 D0 04 0A 0B 0C 78 D0 04 0A 0B 0C

78 D0 04 0A 0B 0C 78 D0 04 0A 0B 0C

78 D0 04 0A 0B 0C 78 D0 04 0A 0B 0C

MISC CRC

There are some free tools available on Internet that can be used to send a magic packet. Please refer to the following link to understand more about Magic Packet.

<http://en.wikipedia.org/wiki/Wake-on-LAN>

- **Wake on Magic Packet from power off state**

When checking this option, the system can wake from S5 (system off with standby power) state when receiving a magic packet.

3.9 Ignition Power Control

The ignition power control module for in-vehicle applications is a MCU-based implementation that monitors the ignition signal and reacts to turn on/off the system according to predefined on/off delay. Its built-in algorithm supports other features such as ultra-low power standby, battery-low protection, system hard-off, etc. In this section, we'll illustrate the principle of ignition power control and operation modes.

3.9.1 Principles of Ignition Power Control

The basic concept of ignition power control module is to control the timing correlation between ignition signal and system power status. A typical timing correlation is described in following diagram.

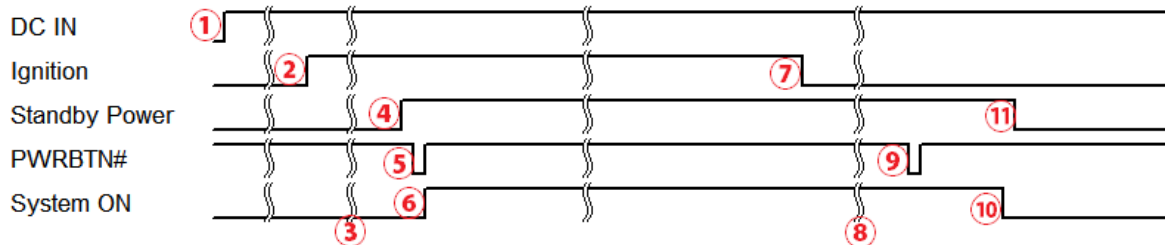

1. When DC power is supplied to the system, MCU starts to periodically detect ignition signal. Note that only MCU is working at this moment and the overall power consumption is less than 2 mW.
2. Ignition signal is active (both 12VDC and 24VDC ignition signals are accepted).
3. MCU starts to count a pre-defined power-on delay.
4. Once power-on delay expired, MCU turns on necessary standby power for the system (3.3VSB & 5VSB).
5. A PWRBTN# pulse is then issued to turn on the system (equivalent to one pressing the power button on the front panel).
6. The system is booting and becomes operational.
7. After a period of time, the ignition signal becomes inactive.
8. MCU starts to count a pre-defined power-off delay.
9. Once power-off delay expired, another PWRBTN# pulse is issued to perform a soft-off for the system (ex. a normal shutdown process for Windows system).
10. The system is completely shut down.
11. As MCU detects system is off, it turns off the standby power for the system, and operates in low power mode again (< 2mW power consumption).

3.9.2 Additional Features of Ignition Power Control

In addition to the typical timing correlation, the ignition power control module offers additional features to provide additional reliability for in-vehicle applications.

- **Low battery detection**

The ignition power control module continuously monitors the voltage of DC input when the system is operational. If input voltage is less than 9V (for 12VDC input) or less than 18V (for 24VDC input) over a 60-second duration, it will shut down the system automatically.

- **Guarded power-on/ power-off delay duration**

If ignition signal goes inactive during the power-on delay duration, the ignition power control module will cancel the power-on delay process and go back to idle status. Likewise if ignition signal goes active during the power-off delay duration, the ignition power control module will cancel the power-off delay process and keep the system running.

- **System hard-off**

In some cases, system may fail to shutdown via a soft-off operation due to system/ application halts. The ignition power control module offers a mechanism called "hard-off" to handle this unexpected condition. By detecting the system status, it can determine whether the system is shutting down normally. If not, the ignition power control module will force cut-off the system power 10 minutes after the power-off delay duration.

- **Smart off-delay**

The ignition power control module offers two modes (mode 13 & mode 14) which have very long power-off delay duration for applications require additional off-line time to process after the vehicle has stopped. In these two modes, the ignition power control module will automatically detect the system status during the power-off delay duration. If the system has shutdown (by the application software) prior to power-off delay expiring, it will cut off the system power immediately to prevent further battery consumption.

3.9.3 Wiring Ignition Signal

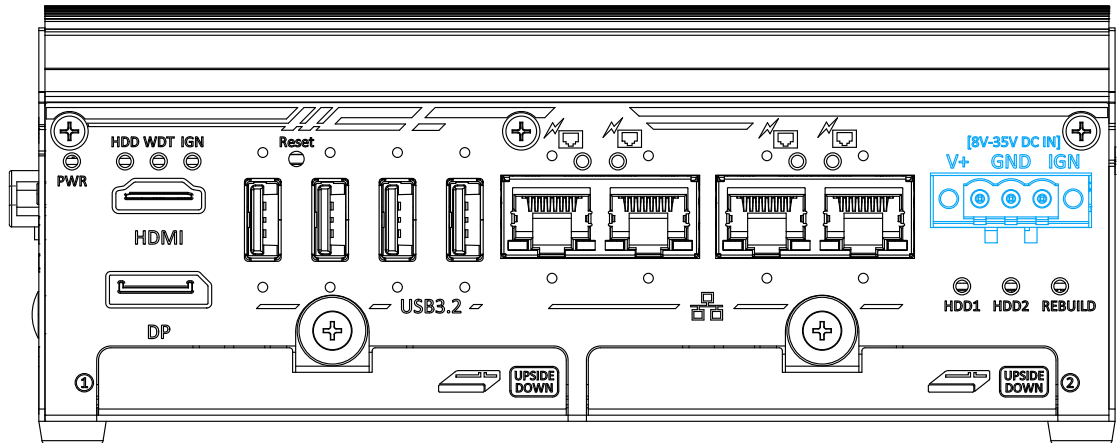

To have ignition power control for in-vehicle usage, you need to supply IGN signal to the system. The IGN input is located on the 3-pin pluggable terminal block (shared with DC power input). For in-vehicle ignition control wiring, please do the following:

1. Connect car Battery+ line (12V for sedan, 24V for bus/truck) to V+.
2. Connect car Batter-/ GND line to GND.
3. Connect ACC line to IGN.



WARNING

Please make sure your DC power source and IGN signal share the same ground. IGN input accepts 8V to 35V DC. Supply a voltage higher than 35V DC may damage the system.

3.9.4 Configure your Windows system

When applying ignition power control to your system, please make sure you've configured your Windows system to initiate a shutdown process when pressing the power button. By default, Windows goes to sleep (S3) mode when power button is pressed. As sleep (S3) is not a complete shutdown behavior, the ignition control function does not recognize the finish of a normal shut down process and thus users will encounter a system hard-off (power cut-off after 10 minutes). Please configure "When I press the power button" to "Shut down" in your Windows system settings.

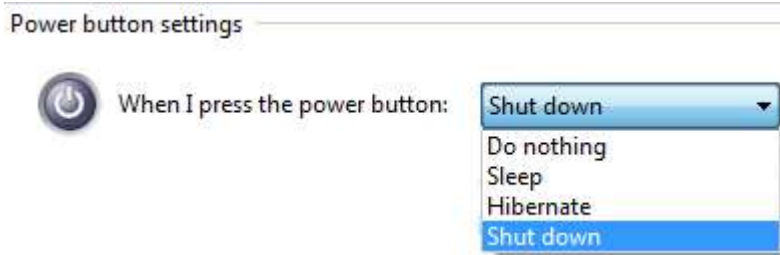

3.9.5 Operation Modes of Ignition Power Control

You can use the rotary switch to configure the operation mode. The system offers 16 (0~15) operation modes with different power-on/power-off delay configurations.

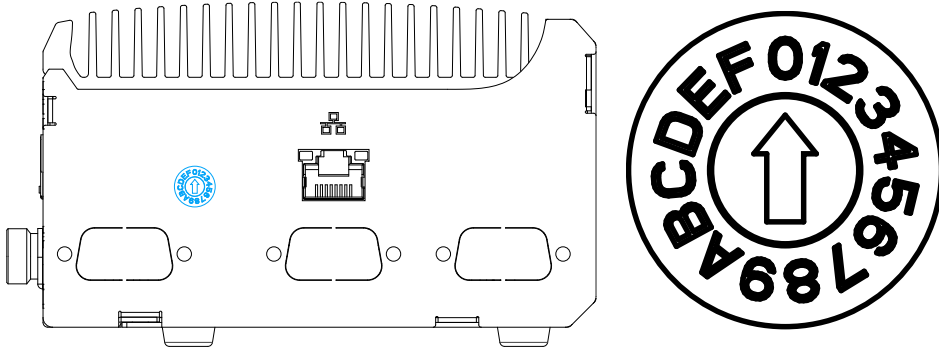

Ignition rotary switch on the reserved punch-out panel

Ignition rotary switch

- **Mode 0**

Mode 0 is the ATX mode without power-on and power-off delay. User can only use the power button on the front panel to turn on or turn off the system.

Mode	Power-on Delay	Power-off Delay	Hard-off Timeout
0	N/A	N/A	N/A

- **Mode 1**

Mode 1 is AT mode without power-on and power-off delay. The system automatically turns on when DC power is applied. A retry mechanism is designed to repeat the power-on cycle if the system fails to boot up.

Mode	Power-on Delay	Power-off Delay	Hard-off Timeout
1	N/A	N/A	N/A

- **Mode 2**

Mode 2 is designed to have a very minor power on/ off delay of 160ms for applications that requires the system to start up almost at the same as the rest of the equipment it is working in collaboration with.

Mode	Power-on Delay	Power-off Delay	Hard-off Timeout
2	160ms	160ms	10 minutes

- **Mode 3 ~ Mode 12**

Mode 3 ~ Mode 12 have various power-on delay and power-off delay. Each mode supports a hard-off timeout of 10 minutes.

Mode	Power-on Delay	Power-off Delay	Hard-off Timeout
3	10 seconds	10 seconds	10 minutes
4	10 seconds	1 minute	10 minutes
5	10 seconds	5 minutes	10 minutes
6	30 seconds	1 minute	10 minutes
7	30 seconds	5 minutes	10 minutes
8	30 seconds	10 minutes	10 minutes
9	3 minutes	1 minute	10 minutes
10 (A)	3 minutes	10 minutes	10 minutes
11 (B)	3 minutes	30 minutes	10 minutes
12 (C)	10 minutes	30 minutes	10 minutes

- **Mode 13 (D) / Mode 14 (E)**

Mode 13 and Mode 14 are ignition power control modes with very long power-off delay. Both modes support the feature of “smart off-delay”, which automatically detect system status during power-off delay duration and cut off system power if system is off in prior to power-off delay expired.

Mode	Power-on Delay	Power-off Delay	Hard-off Timeout
13 (D)	30 seconds	2 hours	10 minutes
14 (E)	3 minutes	2 hours	10 minutes

4 BIOS Settings

The system is shipped with factory-default BIOS settings optimized for best performance and compatibility. In this section, we'll illustrate some BIOS settings you may need to set or change prior to operating system installation. Please always make sure you understand the effect of change before you proceed with any changes. If you are unsure of the function you are changing, it is recommended to change one setting at a time to see its effect(s).

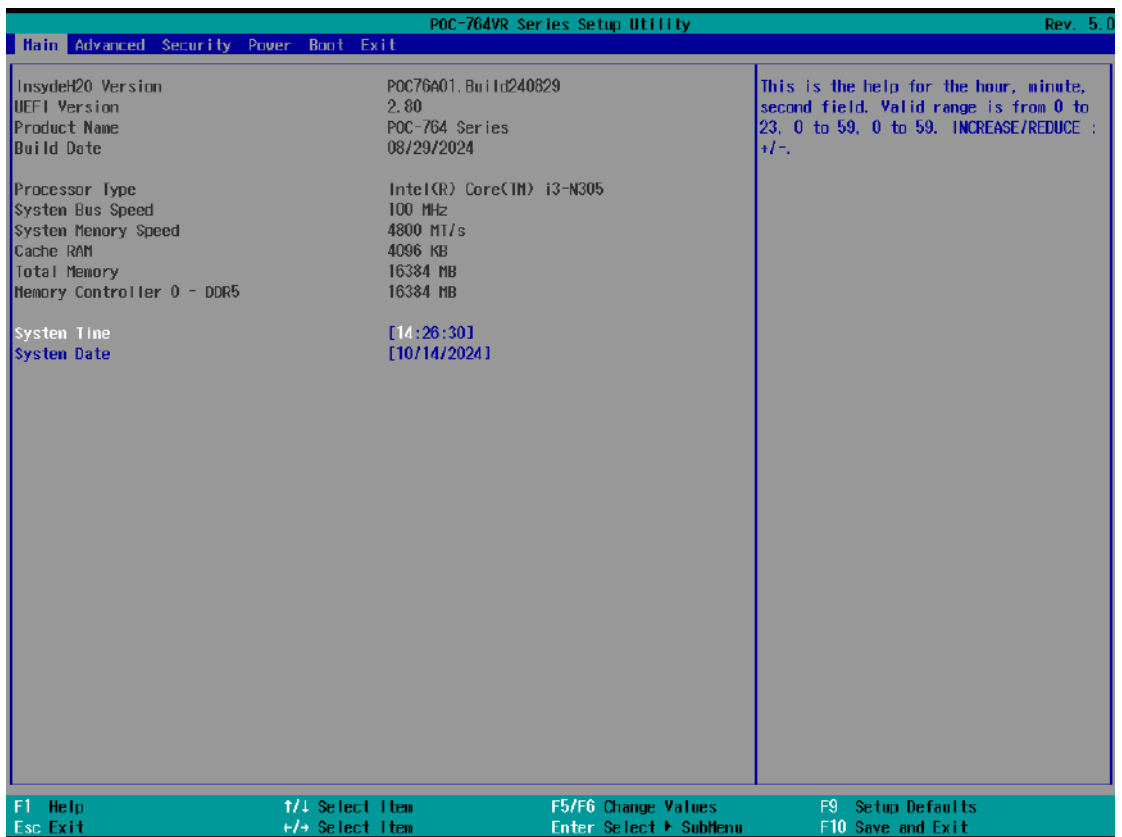

 **NOTE**

Not all BIOS settings will be discussed in this section. If a particular setting/ function you are after requires specific BIOS settings but is not discussed in this section, please contact Neousys Technical Support staff.

4.1 COM1 Port Configuration

The system's COM1 port support RS-232 (full-duplex), RS-422 (full-duplex) and RS-485 (half-duplex) mode. You can set the COM1 operating mode via BIOS settings. The option in the BIOS setting called "Slew Rate" defines how sharp the rising/falling edge is for the output signal of COM1. For long-distance RS-422/485 transmission, you may set the "Slew Rate" option as "High" to improve signal quality. For RS-422/485 communication, the "RS-422/485 Termination" option determines whether to enable/disable internal termination of RS-422/485 transceiver according to your wiring configuration (e.g. with or without external termination).

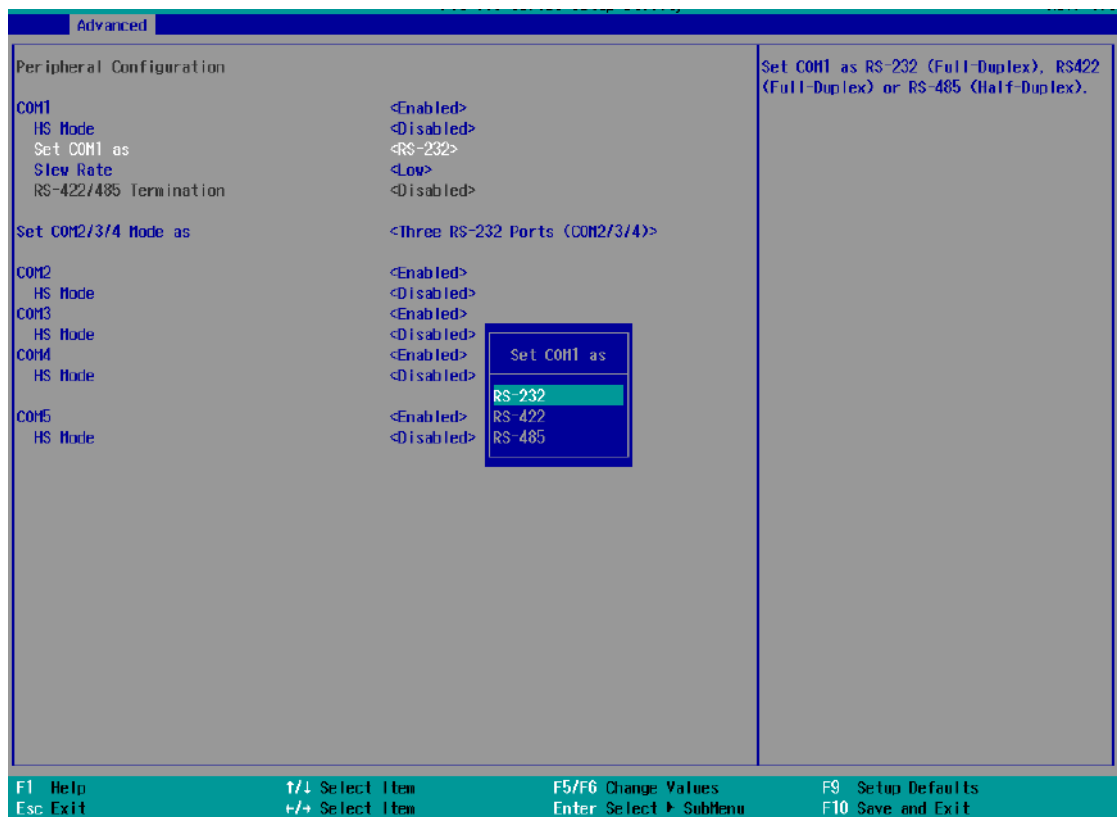

To set COM1 operating mode:

1. Press **F2** when the system boots up to enter the BIOS setup utility.
2. Go to **[Advanced]** → **[Peripheral Configuration]**.
3. Set the **[Set COM1 Mode as]** option to the desired mode.
4. Once set, press **F10** to save setting and exit.

4.2 COM 2/ 3/ 4 Port Configuration

The system's COM 2/ 3/ 4 ports support RS-232 (full-duplex). When set to RS-422/485 mode, it will only act as COM2 port only.

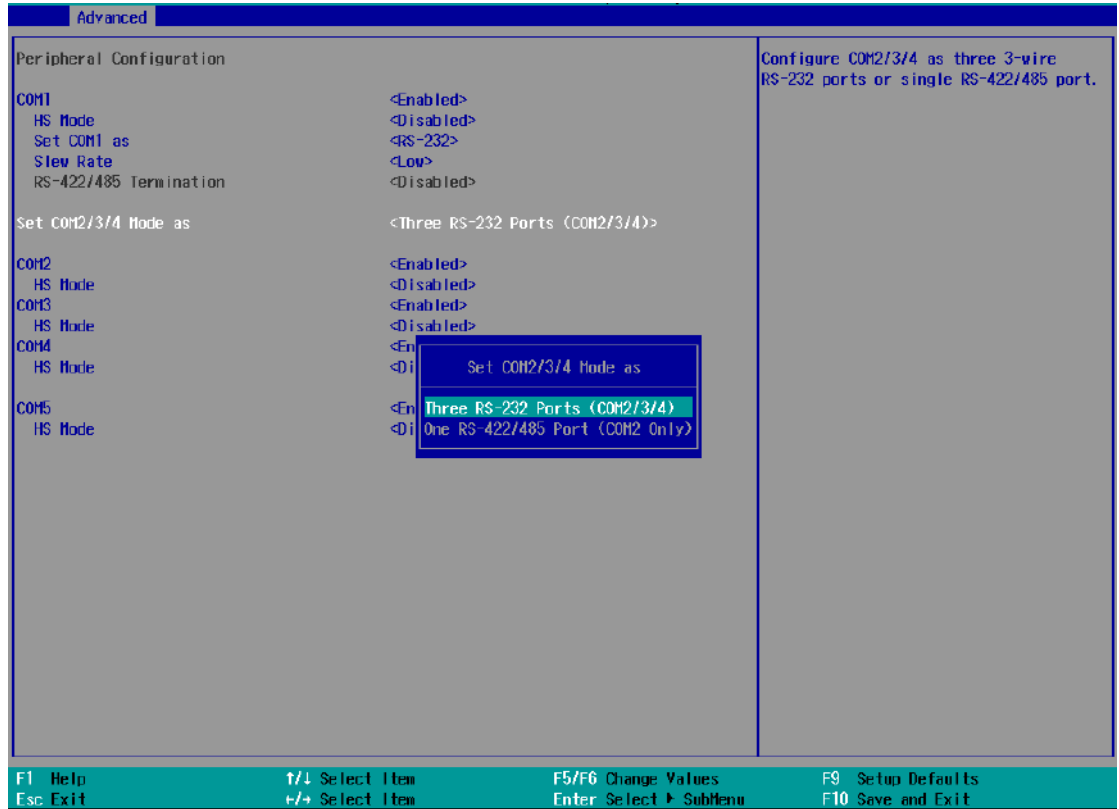

To enable COM/ 3/ 4 operating mode:

1. Press **F2** when the system boots up to enter the BIOS setup utility.
2. Go to **[Advanced]** → **[Peripheral Configuration]**.
3. Highlight the COM port (3 or 4) and set it to <Enabled> .
4. Once set, press **F10** to save setting and exit.

4.3 COM Port High Speed Mode

The high speed mode of each COM port effectively allows for the port's baud rate generator to operate at 8x the speed with an effective baud rate of 921,600 bps (115,200 x 8). Please refer to the following instructions on how to enable the high speed mode for your COM port (COM1 used as an example).



To set COM port high speed mode:

1. Press **F2** when the system boots up to enter the BIOS setup utility.
2. Go to **[Advanced] > [Peripheral Configuration]**.
3. Enable or set the **[Set COM1 Mode as]** option to the desired mode.
4. Highlight **[HS Mode]** and press ENTER to bring up options, highlight **[Enable]** and press ENTER.
5. Once set, press **F10** to save setting and exit.

4.4 SATA Configuration

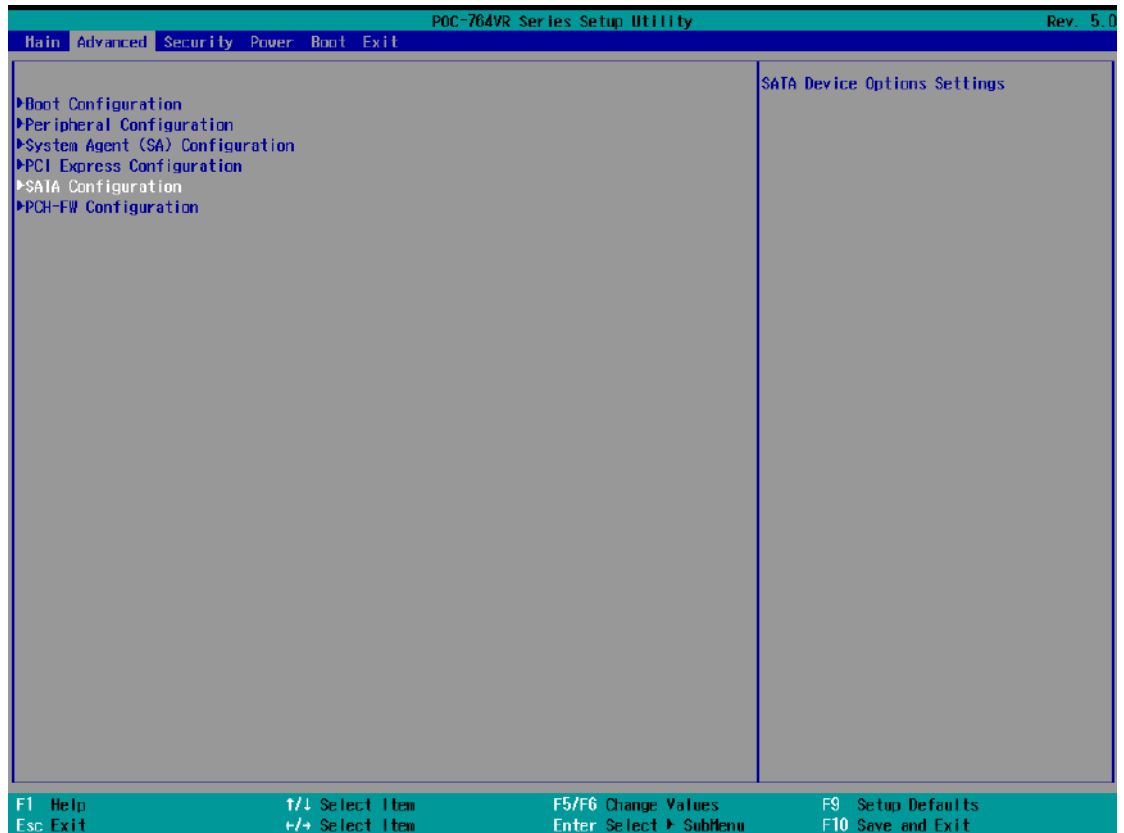

You can view the SATA configuration of the system under this menu. But the actual setting is set via the [dip switches](#). The system supports three modes: RAID-0, RAID-1, and JBOD. To set a mode, you must first set it to PM mode, power on the system, press F2 to enter the BIOS or boot into operating system. Then power off, set it to the mode you want it in, and power the system back on.

Example: Switching from RAID-1 to RAID-0

1. Power off the system
2. Locate dip switch and set it to PM mode
3. Power on the system and enter BIO or boot into OS
4. Power off the system
5. Locate the dip switch and set it to RAID-0
6. Power on the system to complete the process

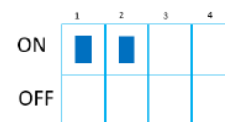
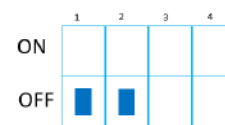

The following table briefly explains the differences between RAID modes and JBOD.

Category	RAID 1 (Mirroring)	RAID 0 (Striping)	JBOD (Just a Bunch of Disks)
Data Protection	High, data is mirrored across drives	None, data is lost if any drive fails	None, data is lost on failed drive but other drives are unaffected
Performance Boost	None, as data is written to multiple drives simultaneously	High, data is split across drives for faster read/write	None, data is written sequentially to each drive
Fault Tolerance	High, system continues if one drive fails	None, failure of any drive results in data loss	None, failure of one drive results in loss of data on that drive only
Use Case	For scenarios requiring high data safety and backup	For scenarios requiring high performance but low data safety	For flexible storage needs with low performance and safety requirements

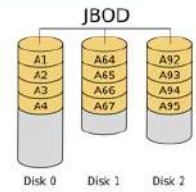
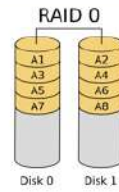
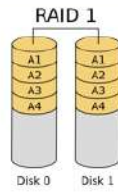

 **NOTE**

For high SATA SSD performance and durability, it is recommended to use SATA SSDs with DRAM cache.

4.4.1 RAID-0 Mode

 **WARNING**

Please back up the hard drive data before you create or modify RAID volume(s) as the process may cause irreversible data deletion. When creating a RAID volume, it is also recommended to use hard drives from the same batch (same brand, model, capacity, rpm rate, etc.) to avoid performance or capacity allocation issues.

 **NOTE**

Please refer to [SATA Configuration](#) for initial drive setup.

RAID-0 (stripping) mode increases performance by storing data on both drives (data is read/ write alternatively, reducing latency). However, this RAID configuration does not offer data redundancy to secure important data. The storage capacity shown represents the storage capacity of both drives.

Dip switch setting

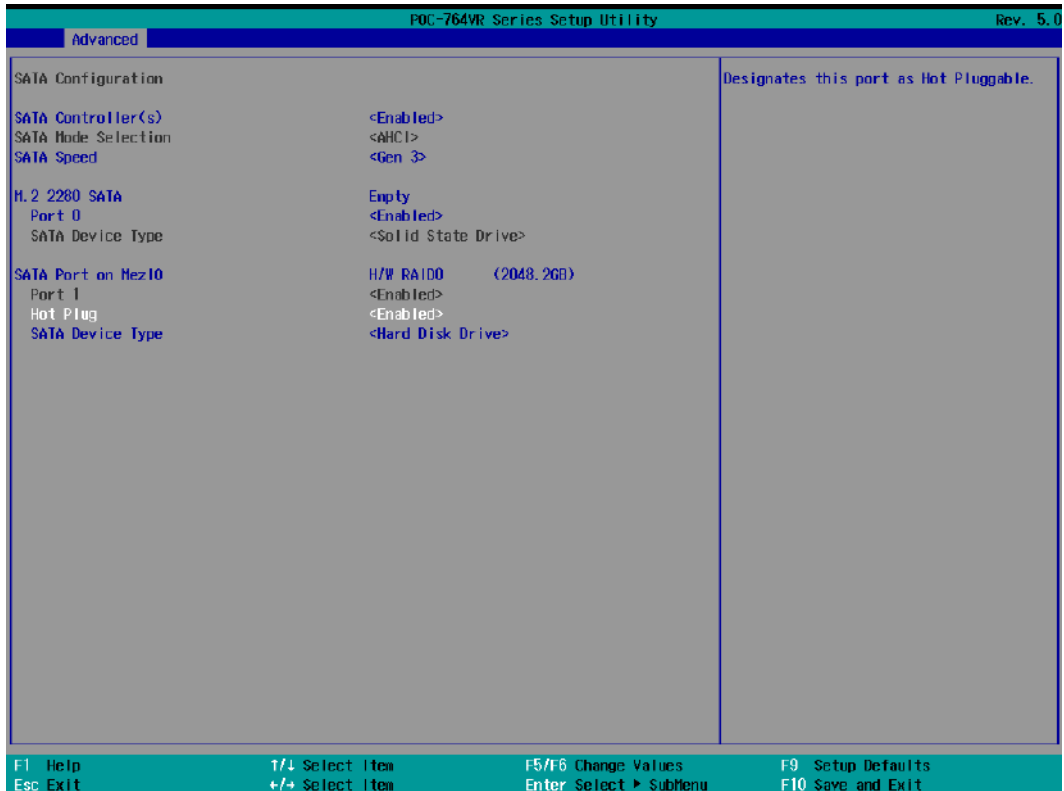
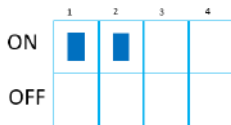

4.4.2 RAID-1 Mode

 **WARNING**

Please back up the hard drive data before you create or modify RAID volume(s) as the process may cause irreversible data deletion. When creating a RAID volume, it is also recommended to use hard drives from the same batch (same brand, model, capacity, rpm rate, etc.) to avoid performance or capacity allocation issues.

 **NOTE**

Please refer to [SATA Configuration](#) for initial drive setup.
RAID 1 supports drive hot swap, but the drive must be brand new or already formatted.

RAID-1 configuration offers complete data redundancy and is one of the safest data backup methods. The data written and mirrored to both drives simultaneously. The storage capacity shown represents the storage capacity of the drive with lesser capacity.

Dip switch setting

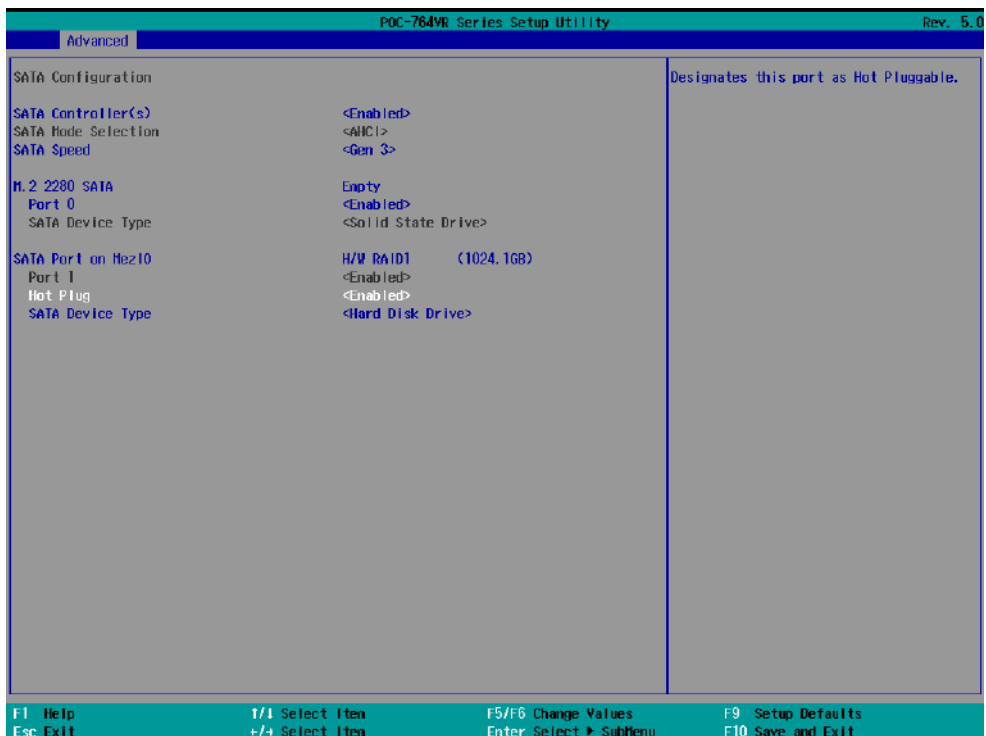
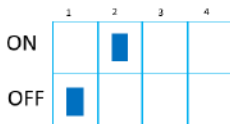

4.4.3 JBOD Mode



WARNING

Please back up the hard drive data before you create or modify RAID volume(s) as the process may cause irreversible data deletion. When creating a RAID volume, it is also recommended to use hard drives from the same batch (same brand, model, capacity, rpm rate, etc.) to avoid performance or capacity allocation issues.



NOTE

Please refer to [SATA Configuration](#) for initial drive setup.

Just a bunch of disks (JBOD) offer general and flexible storage. This mode offers no performance boots or data safety. Data lost on drive 1 does not affect data on drive 2, or vice versa. The storage capacity shown represents the storage capacity of both drives.

Dip switch setting

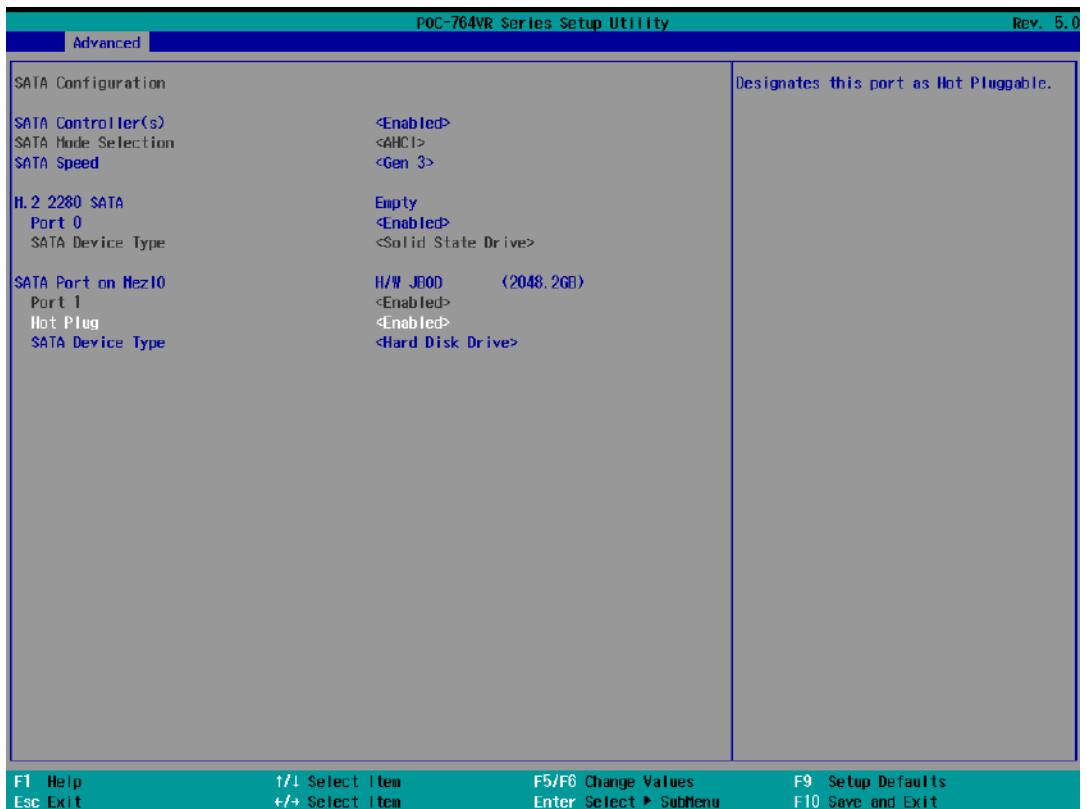
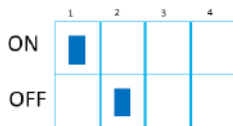

4.5 TPM Availability

Trusted Platform Module (TPM) is a hardware-based cryptoprocessor to secure hardware by integrating cryptographic keys into devices. The system is designed with on-board TPM 2.0 module. It is enabled in the BIOS by default.



To enable TPM availability:

1. When system boots up, press F2 to enter BIOS setup utility.
2. Go to **[Security] > [TPM Availability]**, press ENTER to bring up Options, Available/ Hidden.
3. Highlight your selection, press Enter and press F10 to "Exit Saving Changes".

4.6 Power over Ethernet (PoE)

The Power over Ethernet (PoE) setting in the BIOS allows you to enable/ disable the PoE function of the designated port upon system boot up.

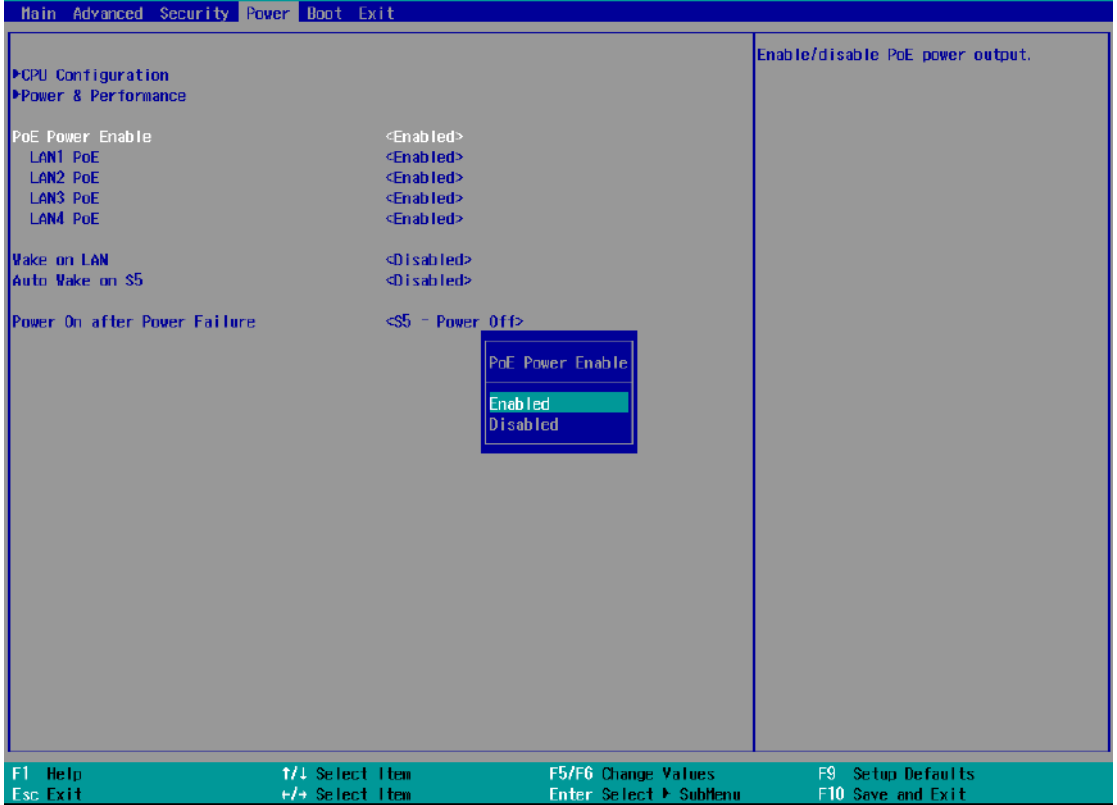

To enable/ disable Power over Ethernet settings:

1. Press **F2** when the system boots up to enter the BIOS setup utility.
2. Go to **[Power]** → **[PoE Enable]**
3. Use the up/ down arrow to highlight and select between Enabled/ Disabled, press Enter to make your selection.
4. When Enabled, you may set each LAN port's PoE function by selecting Enabled/ Disabled using the arrow key, press Enter to make your selection.

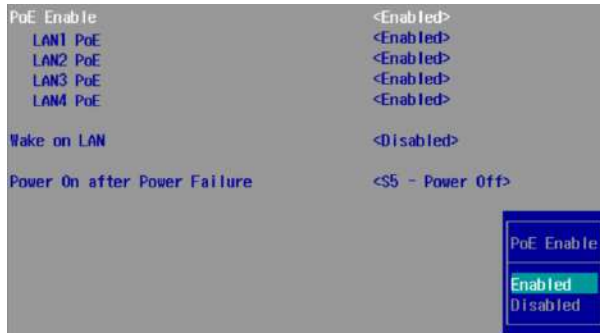

Enable/ Disable LAN PoE function

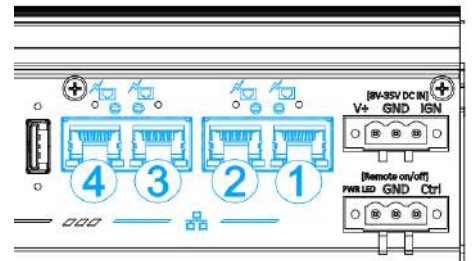

Corresponding LAN ports

5. Once set, press F10 to save setting and exit.

4.7 Wake-on-LAN

Wake-on-LAN (WOL) is a mechanism which allows you to turn on your system via Ethernet connection. To utilize Wake-on-LAN function, you have to enable this option first in BIOS settings. Please refer to Powering on via Wake-on-LAN function.

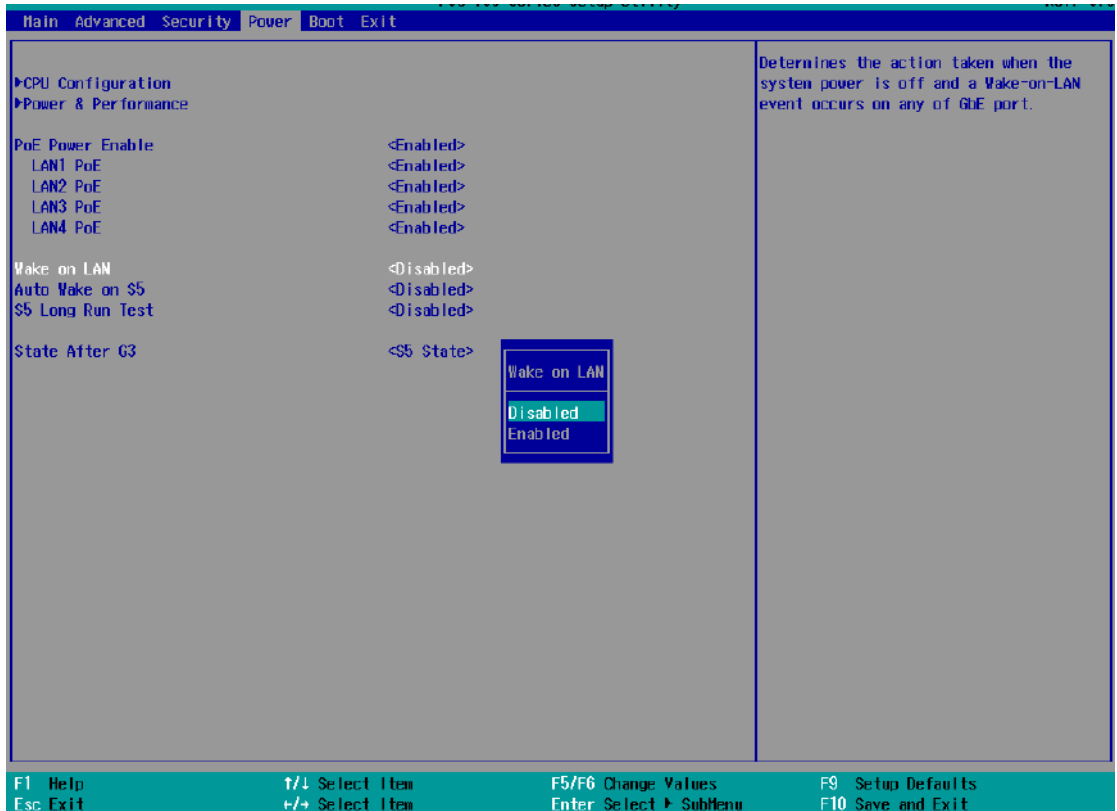

To enable/ disable “Wake on LAN” option:

1. Press **F2** when the system boots up to enter the BIOS setup utility.
2. Go to **[Power]**.
3. You may enable/disable the **[Wake on LAN]** option.
4. Once set, press **F10** to save setting and exit.

4.8 C-States

Intel processors utilize C-States to regulate the power-draw and operating frequency of each core. By enabling this function, it allows BIOS to reduce the operating frequency, power-draw, or both of the idle processor core for the system to operate more efficiently. Please refer to the steps below to enable processor C-States.

To set “Power On after Power Failure” option:

1. Press **F2** when the system boots up to enter the BIOS setup utility.
2. Go to **[Power] > [Power & Performance]** and press **ENTER**.

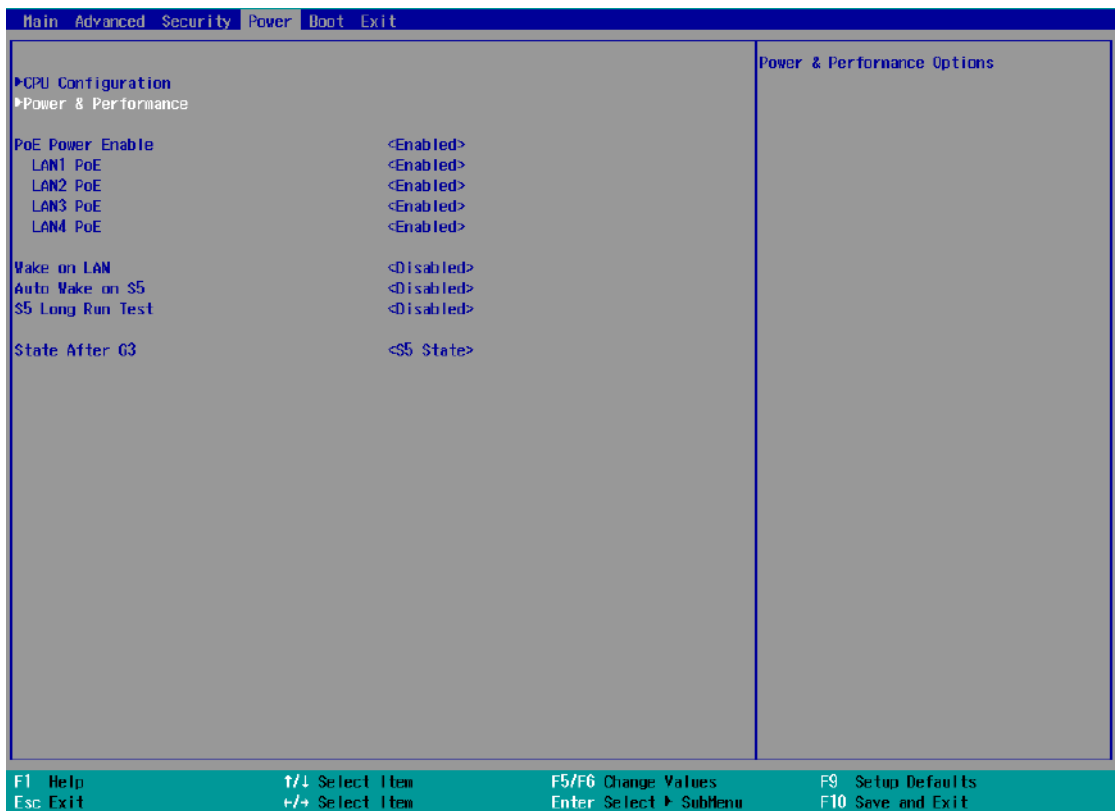

3. Highlight “**C states**” and press ENTER, set to “**Enabled**” and press ENTER.
4. Press F10 to “**Save and Exit**”.

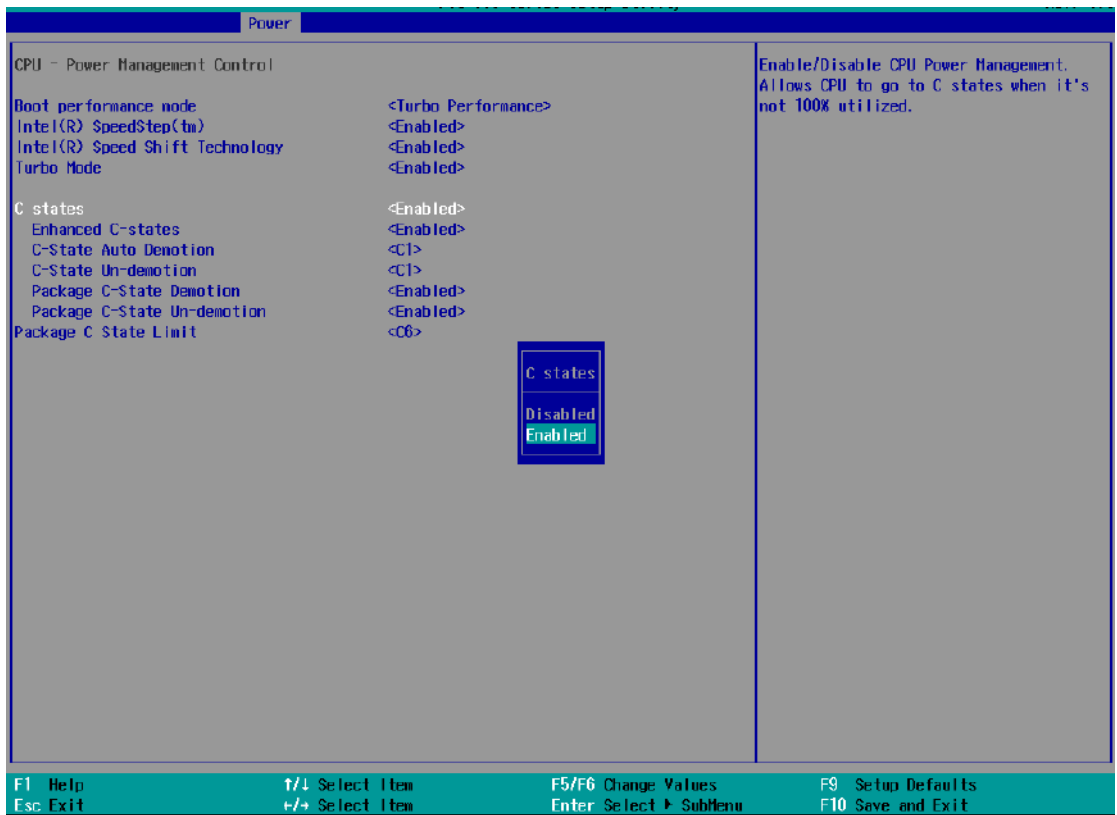

4.9 Power On after Power Failure

This option defines the system's behavior when DC power is supplied.

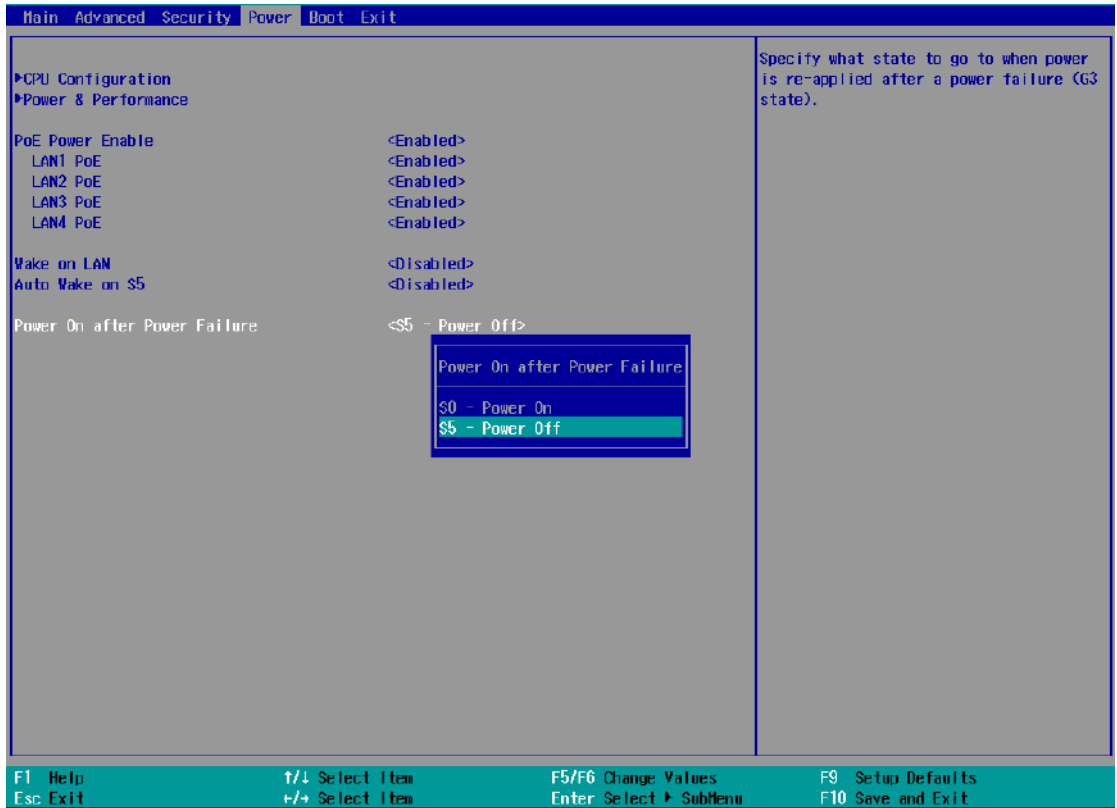

Value	Description
S0 – Power On	System is powered on when DC power is supplied.
S5 – Power Off	System is kept in off state when DC power is supplied.

When you want to use the AT-mode remote on/ off control function, you have to set this option to “S0 – Power On”. Please refer to the section [“Powering on the System”](#) for instructions of using AT-mode remote on/off control function.

To set “Power On after Power Failure” option:

5. Press **F2** when the system boots up to enter the BIOS setup utility.
6. Go to **[Power]**.
7. Set the **[Power On after Power Failure]** option to the desired setting.
8. Once set, press **F10** to save setting and exit.

4.10 Boot Menu

The Boot menu in BIOS allows you to specify the system's boot characteristics by setting bootable device components (boot media) and method. Or, you may press F12 upon system start up and select a device you wish boot from.

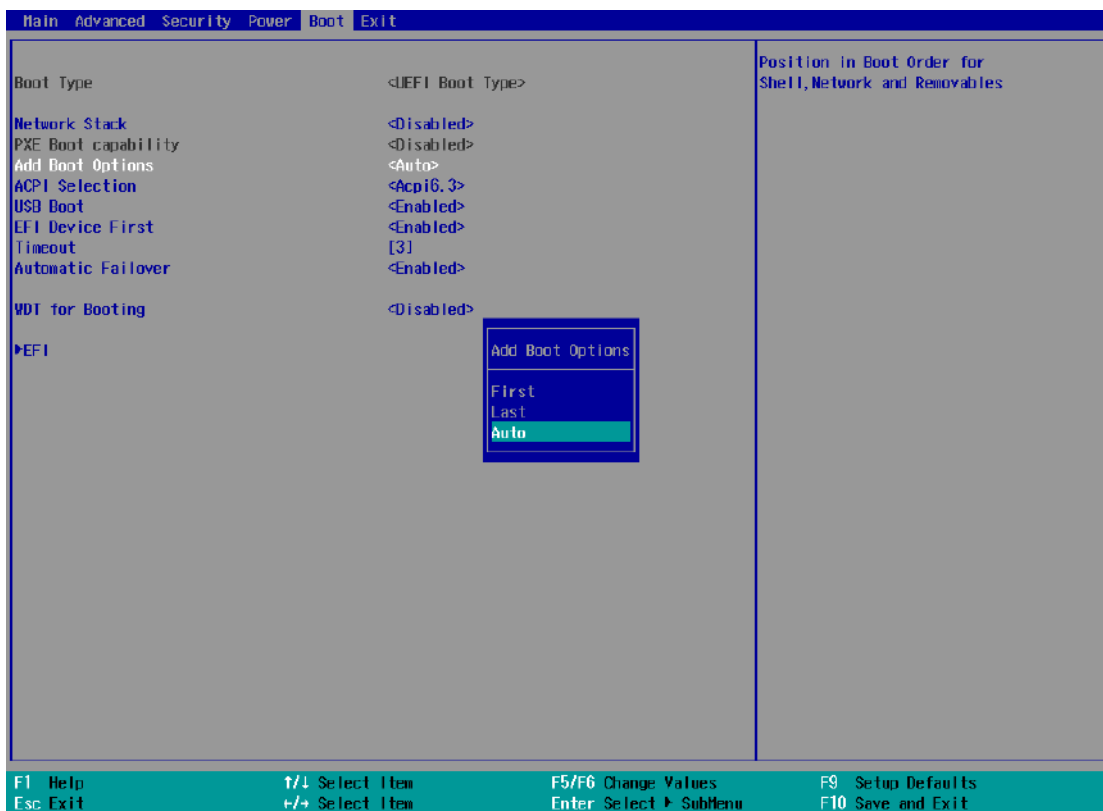

Value	Option	Description
Boot Type	UEFI Boot Type	Only UEFI boot media listed are approved as boot media.
Quick Boot	Enabled	The system starts up faster because BIOS skips various hardware function tests
	Disabled	The system starts up slower because BIOS goes through various hardware functions tests
Network Stack	Enabled	The system is available for network access using UEFI.
	Disabled	The system is not available for network access using UEFI.
PXE Boot capability	Enabled	By enabling this function, it allows the computer to load an operating system over a network connection.
	Disabled	

Add Boot Options	First	Newly detected boot media are placed at the top of the boot order.
	Last	Newly detected boot media are placed at the bottom of the boot order.
	Auto	Newly detected boot media order will be automatically detected and placed in boot order.
ACPI Selection	4.0/ 5.0/ 6.0/ 6.1/ 6.3	Advanced Configuration and Power Interface allows the operating system to control system power management
USB Boot	Enabled	Allow boot from bootable USB devices.
	Disabled	Does not allow boot from bootable USB devices
EFI Device First	Enabled	Set to boot bootable EFI media first.
	Disabled	Will not boot bootable EFI media first.
Timeout	1, 2, 3, etc (in seconds)	Boot delay time in seconds to give the user time to activate the hotkey to access the BIOS
Automatic Failover	Enabled	Automatically checks for the next bootable device when the set default device fails.
	Disabled	Will only boot from the designated device.
WDT for booting	Disabled, 1, 3, 5, 10 (minutes)	WDT ensures a successful system boot by specifying a timeout value

4.11 Position New Boot Device

The “Add Boot Options” allow you to determine whether a newly added device (eg. USB flash disk) is to boot as the first device to boot or the last in the boot sequence.

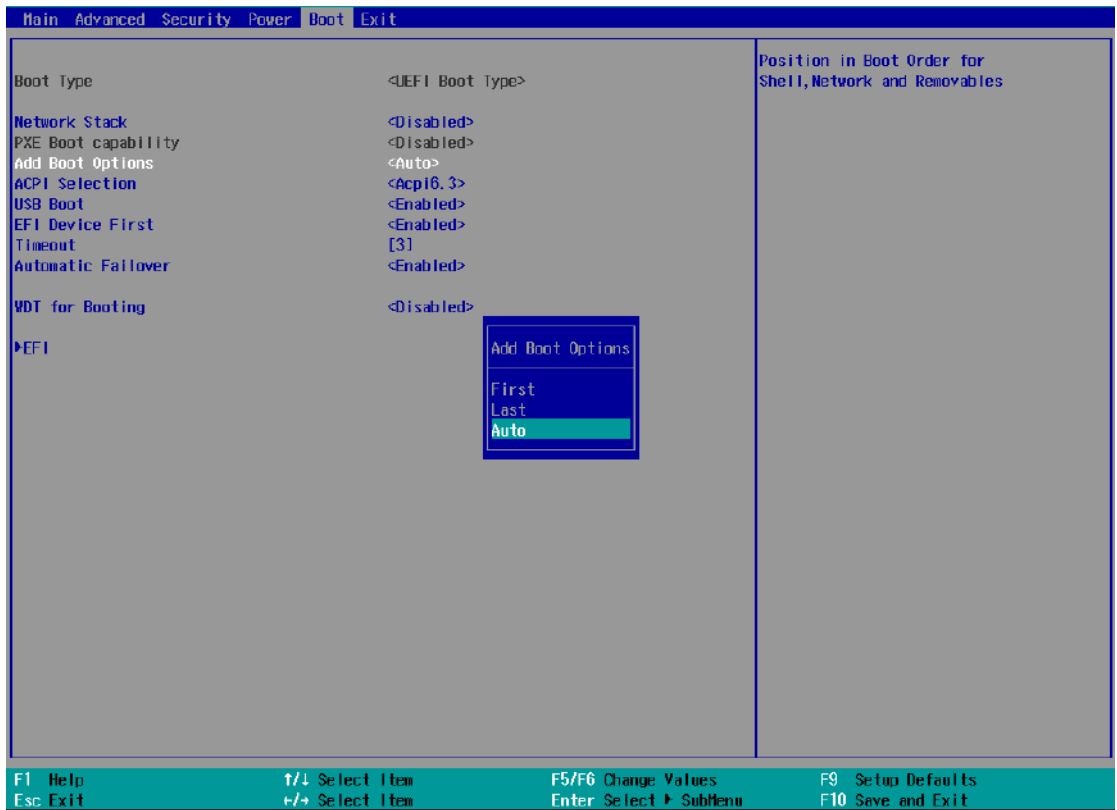

To set the newly-installed boot device as the first or last boot device:

1. Press **F2** when the system boots up to enter the BIOS setup utility.
2. Go to **[Boot] > [Add Boot Options]** menu.
3. Select **[First]** or **[Last]** for your newly-added boot device and press Enter.
4. Once set, press **F10** to save setting and exit.

4.12 Watchdog Timer

The watchdog timer secures the boot process by means of a timer. Once the timer expires, a reset command is issued to initiate another booting process. There are two options in BIOS menu, “*Automatically after POST*” and “*Manually after Entering OS*”. When “*Automatically after POST*” is selected, the BIOS automatically stops the watchdog timer after POST (Power-On Self Test) OK. When “*Manually after Entering OS*” is selected, the user must stop the watchdog timer once booted into the OS.

This guarantees the system can always boot into the OS, otherwise another booting process will be initiated. For information about programming watchdog timer, please refer to [Appendix A Using WDT & DIO](#).



To set the watchdog timer for boot in BIOS:

1. Press **F2** when the system boots up to enter the BIOS setup utility.
2. Go to **[Boot]** menu.
3. Disable or select timeout value for **[WDT for Booting]** option.
4. Once you set a timeout value, the **[WDT Stop Option]** option appears. You can select either “*Automatically after POST*” or “*Manually after Entering OS*”.
5. Once set, press **F10** to save setting and exit.

5 OS Support and Driver Installation

5.1 Operating System Compatibility

The system supports most operating system developed for Intel® x86 architecture. The following list contains the operating systems which have been tested by Neosys Technology.

- Microsoft Window 10 LTSC 2021 (x64)
- Microsoft Windows 11 IoT Enterprise 22H2 64-bit
- Ubuntu 20.04.2 LTS or other distribution with kernel version ≥ 5.19 */**



NOTE

For other Linux OS, Linux kernel should upgrade to 5.19

**For Linux system, user may need to manually compile and install the driver for Intel graphics or Ethernet controller if the driver is not embedded in kernel. You can visit Intel website for further information.*

***For distributions, graphics driver may not be completely implemented in its kernel. You may encounter restrictions when using these features, such as multiple independent displays. For optimum operation, it is the users' responsibility to manually check for new drivers and upgrades!*

Neosys may remove or update operating system compatibility without prior notice. Please contact us if your operating system of choice is not on the list.

5.2 Driver Installation

The system drivers are available online, please click on this [link](#) to download the drivers.

5.3 Driver Installation for Watchdog Time Control

Neosys provides a driver package which contain function APIs for Watchdog Timer control function. You should install the driver package (WDT_DIO_Setup.exe) in prior to use these functions. Please download the latest version of WDT_DIO_Setup.exe to ensure compatibility.

Please refer to this [link](#) to download WDT_DIO.

Appendix A Using WDT & DIO

The watchdog timer (WDT) function ensures reliable system operation. The WDT is a hardware mechanism to reset the system if the watchdog timer is expired. Users can start the WDT and keeping resetting the timer to make sure the system or program is running. Otherwise, the system shall be reset.

In this section, we'll illustrate how to use the function library provided by Neosys to program the WDT functions. Currently, WDT driver library supports Windows 10 x64 and WOW64 platform. For other OS support, please contact Neosys Technology for further information.

Installing WDT_DIO Library

The WDT_DIO function library is delivered in the form of a setup package named **WDT_DIO_Setup.exe**. In prior to program WDT, you should execute the setup program and install the WDT library. Please use the following WDT_DIO_Setup packages according to your operating systems and application.



NOTE

Please download from Neosys website and install the latest WDT_DIO_Setup.exe file.

WDT and DIO Library Installation

WDT_DIO_Setup.2.4.0.0.exe will be used as an example to demonstrate WDT & DIO Library installation setup process. Please refer to the instructions below.

1. Execute **WDT_DIO_Setup.2.4.0.0.exe**.

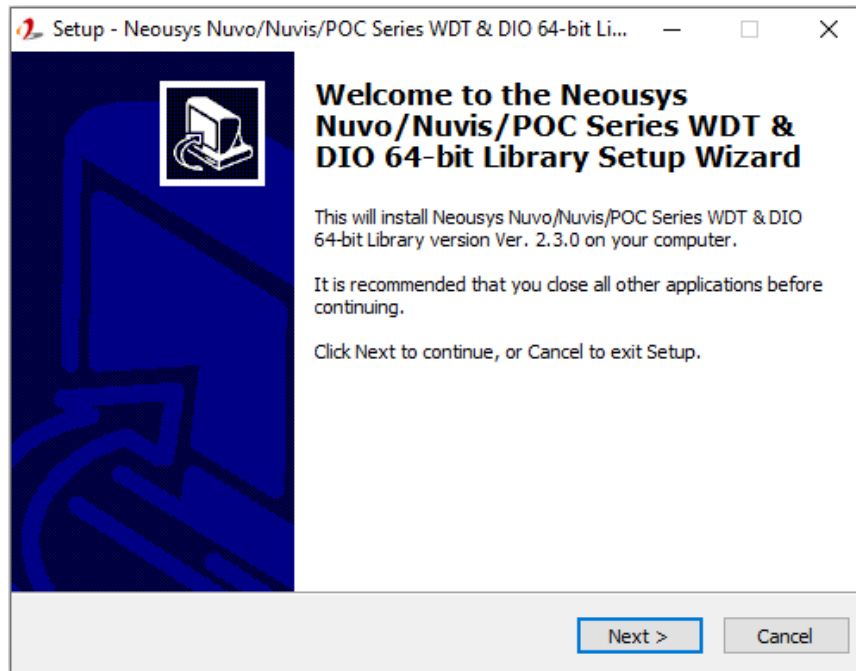

2. Click "Next >" and specify the directory of installing related files. The default directory is *C:\Neosys\WDT_DIO*.

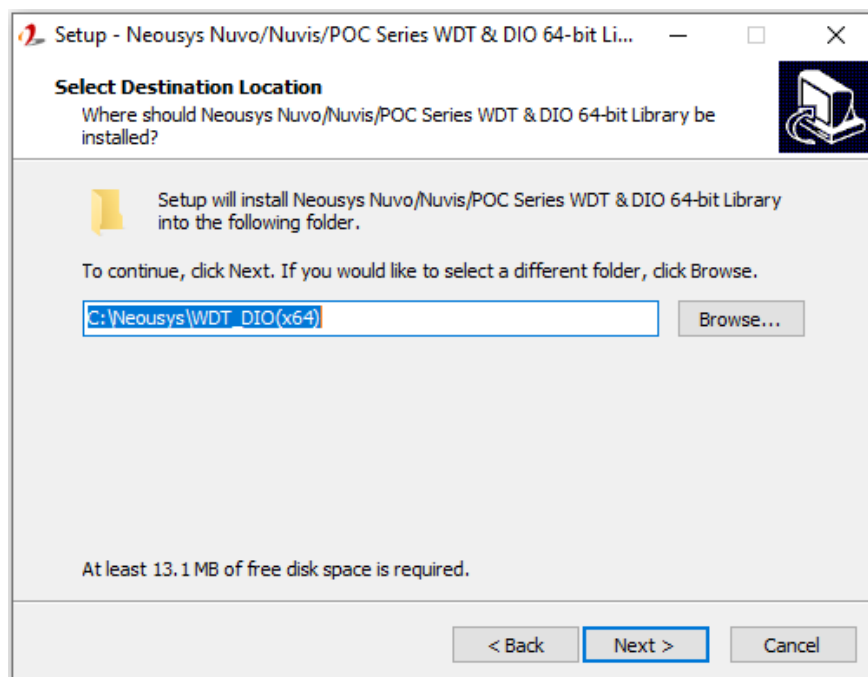

- Once the installation has finished, a dialog will appear to prompt you to reboot the system. The WDT & DIO library will take effect after the system has rebooted.

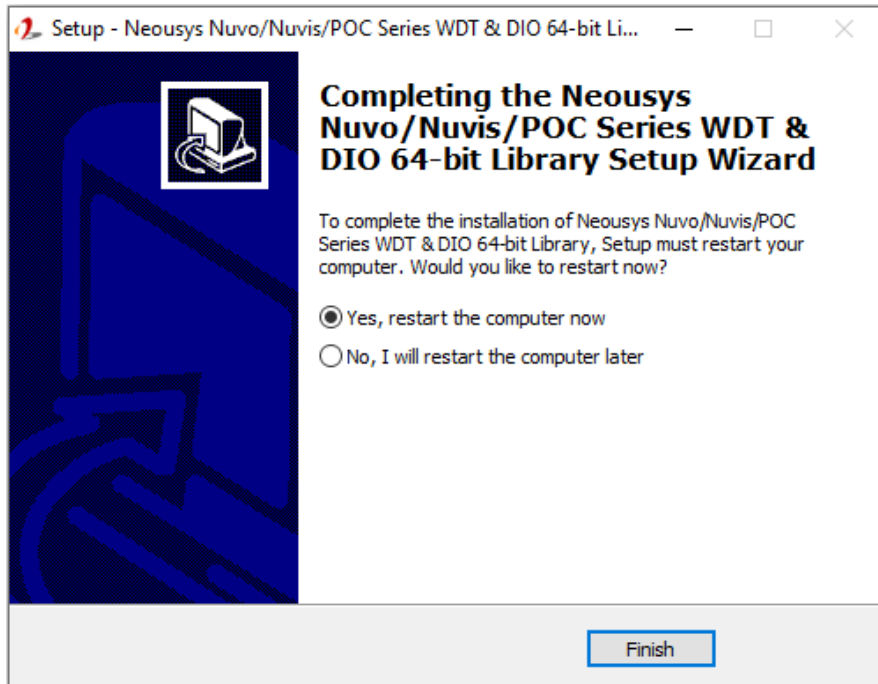

- When programming your WDT or DIO program, the related files are located in

Header File:	\Include
Library File:	\Lib
Function Reference:	\Manual
Sample Code:	\Sample\WDT_Demo (Demo for Watchdog Timer) \Sample\DIO_Demo (Demo for isolated DIO Control) \Sample\COS_Demo (Demo for change-of-state DI)

WDT Function Reference

InitWDT

Syntax	BOOL InitWDT(void);
Description:	Initialize the WDT function. You should always invoke InitWDT() before set or start watchdog timer.
Parameter	None
Return Value	TRUE: Successfully initialized FALSE: Failed to initialize
Usage	BOOL bRet = InitWDT();

SetWDT

Syntax	BOOL SetWDT(WORD tick, BYTE unit);
Description	Set timeout value and unit for watchdog timer. When InitWDT() is invoked, a default timeout value of 255 seconds is assigned.
Parameter	<i>tick</i> WORD value (1 ~ 65535) to indicate timeout ticks. <i>unit</i> BYTE value (0 or 1) to indicate unit of timeout ticks. 0 : unit is minute 1: unit is second
Return Value	If value of unit is correct (0 or 1), this function returns TRUE, otherwise FALSE.
Usage	WORD tick=255; BYTE unit=1; //unit is second. BOOL bRet = SetWDT(tick, unit); //timeout value is 255 seconds

StartWDT

Syntax	BOOL StartWDT(void);
Description	Starts WDT countdown. Once started, the WDT LED indicator will begin blinking. If ResetWDT() or StopWDT is not invoked before WDT countdowns to 0, the WDT expires and the system resets.
Parameter	None
Return Value	If the timeout value is given in correct format (WDT started), this function returns TRUE, otherwise FALSE
Usage	BOOL bRet = StartWDT()

ResetWDT

Syntax	BOOL ResetWDT(void);
Description	Reset the timeout value to the value given by SetWDT().If ResetWDT() or StopWDT is not invoked before WDT countdowns to 0, the WDT expires and the system resets.
Parameter	None
Return Value	Always returns TRUE
Usage	BOOL bRet = ResetWDT()

StopWDT

Syntax	BOOL StopWDT(void);
Description	Stops the countdown of WDT. When WDT has stopped, the WDT LED indicator stops blinking.
Parameter	None
Return Value	Always returns TRUE
Usage	BOOL bRet = StopWDT()

DIO Functions

InitDIO

Syntax	BOOL InitDIO(void);
Description	Initialize the DIO function. You should always invoke InitDIO() before write/read any DIO port/channel.
Parameter	None
Return Value	Returns TRUE if initialization successes, FALSE if initialization failed.
Usage	BOOL bRet = InitWDT();

DIReadLine

Syntax	BOOL DIReadLine(BYTE ch);
Description	Read a single channel of isolated digital input.
Parameter	ch BYTE value specifies the DI channel to be read. <i>Ch</i> should be a value of 0 ~ 7.
Return Value	The status (TRUE or FALSE) of the specified DI channel.
Usage	BYTE ch=3; //DI channel #3 BOOL DIChValue = DIReadLine(ch); //read DI channel #3

DIReadPort

Syntax	WORD DIReadPort(void);
Description	Read the entire isolated digital input port (8 channels).
Parameter	None
Return Value	A WORD value (0~255) indicates the status of DI port (8 DI channels).
Usage	WORD DIPortValue = DIReadPort ();

DOWriteLine

Syntax	void DOWriteLine(BYTE ch, BOOL value);
Description	Write a single channel of isolated digital output.
Parameter	<p>ch BYTE value specifies the DO channel to be written. <i>Ch</i> should be a value of 0 ~ 7.</p> <p>value BOOL value (TRUE or FALSE) specifies the status of DO channel.</p>
Return Value	None
Usage	<pre> BYTE ch=3; //DI channel #3 BOOL DOChValue=TRUE; DOWriteLine(ch, DOChValue); //write DO channel #3 as TRUE </pre>

DOWritePort

Syntax	void DOWritePort(WORD value);
Description	Write the entire isolated digital output port (8 channels).
Parameter	<p>value WORD value specifies the status of the DO port. <i>Value</i> should be a value of 0~255.</p>
Return Value	None
Usage	<pre> WORD DOPortValue=0XFF; //11111111b DOWritePort(DOPortValue); //write DO port as 11111111b </pre>

Appendix B PoE On/ Off Control

The system offers four 802.3at PoE+ ports with a unique feature to allow users manually turn on or off the power supply of each PoE port. This can be function can be useful in power device (PD) fault-recovery or power reset.

The function APIs are encapsulated in Neousys WDT_DIO driver package. Please follow the instructions in [Appendix A Watchdog Timer & Isolated DIO](#) to install the driver package prior to programming PoE on/off control function

PoE On/ Off Control Function Reference

GetStatusPoEPort

Syntax	BYTE GetStatusPoEPort (Byte port);
Description	Get current on/off status of designated PoE port.
Parameter	<i>port</i> BYTE value specifies the index of PoE port. Please refer to the following illustration, <i>port</i> should be a value of 1 ~ 4.
Return Value	BYTE value indicating PoE on/off status 0 if port is disabled (off) 1 if port is enabled (on)
Usage	BYTE bEnabled = GetStatusPoEPort (1); //Get on/off status of PoE Port#1

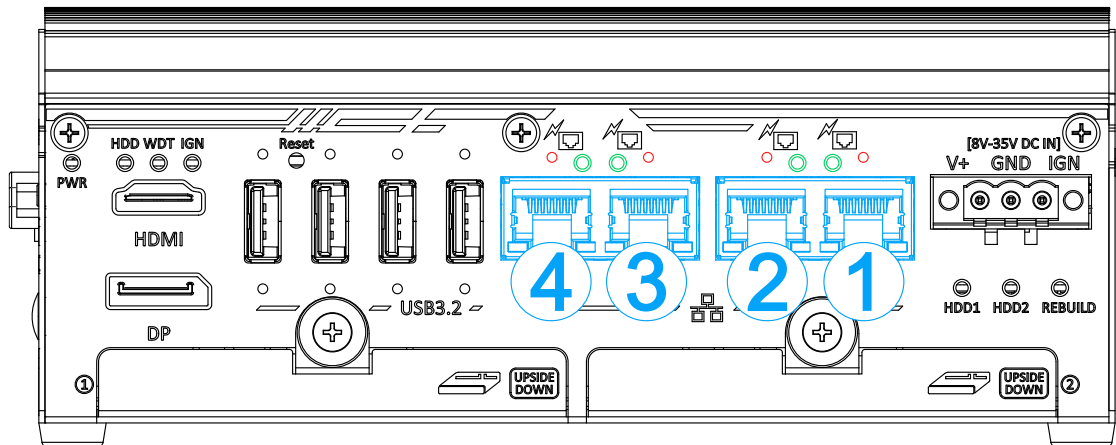

EnablePoEPort

Syntax	BOOL EnablePoEPort (BYTE port);
Description	Turn on PoE power of designated PoE port.
Parameter	<i>port</i> BYTE value specifies the index of PoE port. Please refer to the following illustration, <i>port</i> should be a value of 1 ~ 4
Return Value	TRUE if enabled success FALSE if fail to enable.
Usage	BOOL bRet = EnablePoEPort (1); //Turn on PoE Port#1

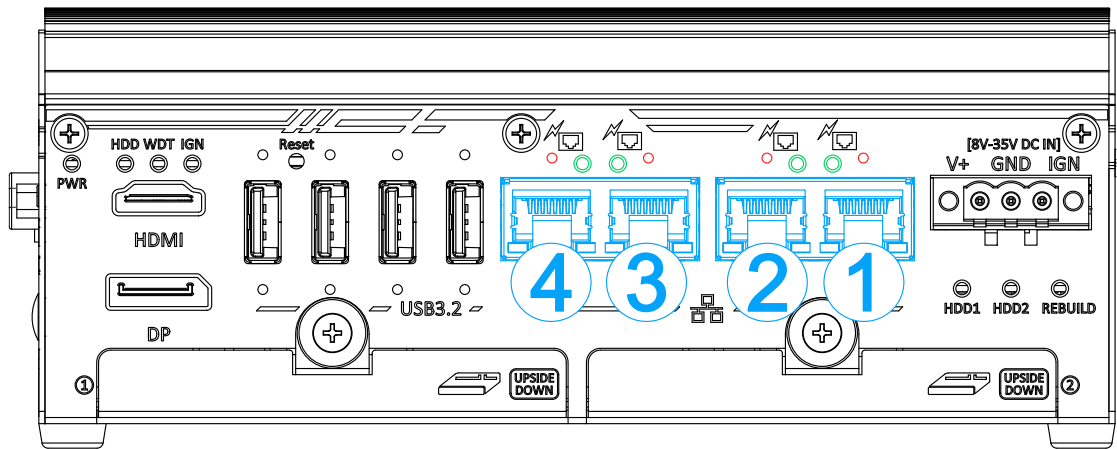

DisablePoEPort

Syntax	BOOL DisablePoEPort (BYTE port);
Description	Turn off PoE power of designated PoE port
Parameter	<i>port</i> BYTE value specifies the index of PoE port. Please refer to the following illustration, <i>port</i> should be a value of 1 ~ 4
Return Value	TRUE if disabled success FALSE if fail to disable
Usage	BOOL bRet = DisablePoEPort (1); //Turn off PoE Port#1

