

PPC-321 1SW

21.5" Fanless Panel PC with Intel® Core™ i Processor



Features

- Industrial-grade 21.5" LCD panel with 50k backlight lifetime
- True-flat touchscreen with multi-touch projected capacitive control
- High-performance, fanless 6th generation Intel® Core™ i processor
- Up to 16 GB DDR4 SDRAM
- Compact, fanless design with aluminum alloy enclosure
- IP65-rated front panel
- Supports dual displays (1 x external HDMI)
- Supports full-size mini PCIe expansion
- Supports USB 3.0
- Supports VESA 100
- Supports TPM 2.0 (optional)



Introduction

The PPC-3211SW is an all-in-one light panel PC with a wide format 21.5" industrial-grade LCD. Powered by 6th generation Intel® Core™ i processor, PPC-3211SW provides excellent performance, memory, graphics, and peripheral I/O support in a compact, fanless, embedded system. With a high durability design, PPC-3211SW features a true-flat touchscreen with IP65-rated front panel, and die cast aluminum alloy enclosure, making it ideal for diverse applications.

Specifications

System	CPU	i3-6100U	i5-6300U	i7-6600U (Optional)
	Cores	Dual Core	Dual Core	Dual Core
	Frequency	2.3 GHz	2.4 GHz; 3.0 GHz with turbo boost	2.6 GHz; 3.4 GHz with turbo boost
	L3 Cache	3 MB	3 MB	4 MB
	TDP	15W	15W	15W
	Memory	1 x SODIMM DDR4 1866/2133 MHz (max. 16 GB) (1.2 V)		
	Storage	1 x 2.5" SATA bay 1 x mSATA bay		
	Network (LAN)	2 x 10/100/1000 Mbps Ethernet (Intel I211-AT; Intel I219LM)		
	I/O	2 x Serial ports: 1 x RS-232, 1 x RS-232/422/485 (Adjustable through BIOS) 2 x USB 3.0, 2 x USB 2.0 1 x HDMI 1 x TPM 2.0 internal (optional)		
	Speaker	2 x 1W		
	Expansion	1 x Full-size mini PCIe slot		
	Watchdog Timer	255 timer levels, set up by software		
Physical Characteristics	Dimensions	558.4 x 349.8 x 62.2 mm (21.9 x 13.7 x 2.4 in)		
	Weight	6.8 kg (14.9 lb)		
OS Support	OS Support	Microsoft® Windows 7(32/64-bit)/10(64-bit), WES7P, Windows 10 IOT LTSC, Linux		
Power Consumption	Input Voltage	12 ~ 24 V _{DC}		
	Power Consumption	75W		
LCD	Display Type	21.5" TFT LCD (LED backlight)		
	Resolution	1920 x 1080		
	Viewing Angle	89 (left), 89 (right), 89 (up), 89 (down)		
	Luminance (cd/m ²)	300		
	Contrast Ratio	5000		
	Backlight Lifetime	50,000 hr		
Touchscreen	Touch Type	10-point multi-touch projected capacitive		
	Light Transmission	90 % ± 3 %		
	Controller	USB interface		
Environment	Operating Temperature	0 ~ 50 °C (32 ~ 122 °F) for SSD 0 ~ 45 °C (32 ~ 113 °F) for HDD		
	Storage Temperature	-20 ~ 60 °C (-4 ~ 140 °F)		
	Relative Humidity	10 ~ 95% @ 40 °C (non-condensing)		
	Shock	Operating 10 G peak acceleration (11 ms duration), follow IEC 60068-2-27		
	Vibration	Operating Random Vibration Test 5 ~ 500Hz, 1Grms @with HDD; 2Grms @with SSD, follow IEC 60068-2-64		
	EMC	CE, FCC Class B, BSMI		
	Safety	CB, CCC, BSMI, UL		
	Front Panel Protection	IP65 compliant		

Dimensions

Unit: mm

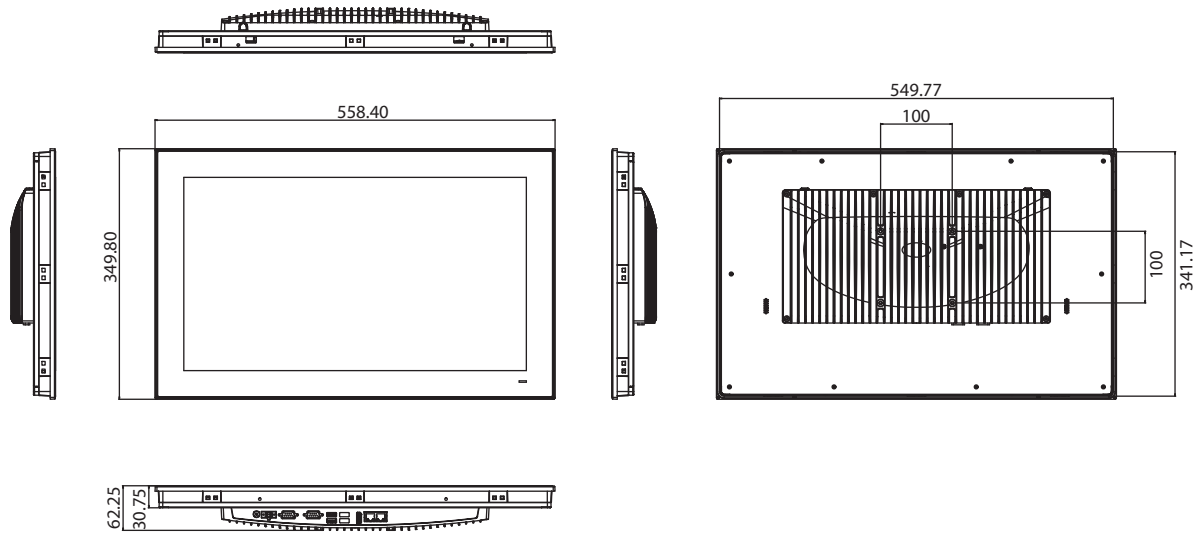
Panel Cutout Dimensions: 550.3 x 341.8 mm (21.66 x 13.45 in)

Ordering Information

Part Number	Description
PPC-3211SW-P65A	Intel Core i5-6300U Fanless Panel PC with 21.5" Full HD LED backlight
PPC-3211SW-P65AU	Intel Core i5-6300U Fanless Panel PC with 21.5" Full HD LED backlight , for U.S. only
PPC-3211SW-P63A	Intel Core i3-6100U Fanless Panel PC with 21.5" Full HD LED backlight
96PSA-A90W190T-3	A/D 100-240V 90W 19V C6 TERMINAL 2 PIN 62368
PPC-WLAN-C1E	M.2 Wi-Fi Module with Antenna cable support 2T2R
PPC-ARM-A03	ARM VESA Standard (A-CLEVER) for PPC series
PPC-174T-WL-MTE	Wall mount kit for PPC series
PPC-Stand-A1E	Stand for PPC series
1700001524	Power cord 3P UL 10A 125V 1.8M
170203183C	Power cord 3P Europe (WS-010+083) 183cm
1700008921	Power cord 3P/3P 1.8M PSE
96CB-POWER-B-1.8MB	Power cord 3P CCC(China) 1.8M
98R3P315100	TPM 2.0 module

I/O View

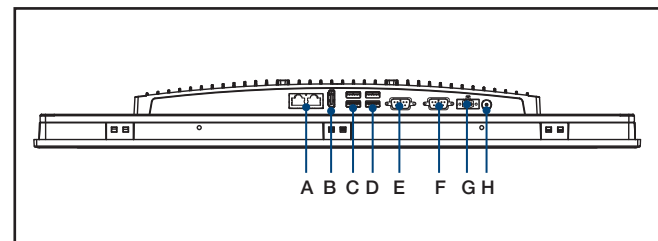

- | | |
|----------------|-------------------------|
| A. 2 x LAN | E. COM2: RS-232/422/485 |
| B. HDMI | F. COM1: RS-232 |
| C. 2 x USB 3.0 | G. DC-In |
| D. 2 x USB 2.0 | H. Power Button |