

Touch Panel Computer with 8th Gen. Intel® Core™ i3/ i5/ i7 Processor, built-in 8G DDR4 RAM



Introduction

TPC-3xx touch panel computer is equipped with TFT LCD, low-power 8th Gen. Intel® Core™ i3- 8145UE dual-core/ i5-8365UE quad-core/ i7-8665UE quad-core processor, and built-in 8 GB DDR4 SO-DIMM delivering high performance yet compact and fanless computing system. To provide enhanced durability and satisfy diverse applications of industrial automation, TPC-3xx features IP66-rated front panel protecting against dust and water ingress, and two extra expansion M.2 M Key, B Key slots supporting NVMe, SATA or 5G application. With Advantech's iDoor technology integrated via mini PCIe slot for function expansions such as additional I/O ports, isolated digital I/O, fieldbus protocols, GPS/GPRS/Wi-Fi communication and MRAM. The integrated DP and audio ports allow a secondary monitor and speakers to be attached for increased functionality.

Specifications

General

- **BIOS** AMI UEFI
- **Certification** BSMI, CCC, CE, FCC Class A, CB/UL
- **Cooling System** Fanless design
- **Dimensions (W x H x D)** 12.1": 311.8 x 238 x 67 mm (12.28 x 9.37 x 2.64 in)
15": 383.2 x 307.3 x 66.5 mm (15.09 x 12.10 x 2.62 in)
17": 410.4 x 343.4 x 68 mm (16.16 x 13.52 x 2.68 in)
23.8": 595.9 x 374.1 x 70 mm (23.46 x 14.73 x 2.76 in)
- **Enclosure** Front bezel: Die cast aluminum alloy
Back housing: Die cast aluminum alloy
- **Mounting** VESA Mount, Desktop, Wall or Panel Mount
- **OS Support** Win 10, Android, Linux
- **Power Consumption** 12.1": 41.06W (Typical)
15": 36.79W (Typical)
17": 45.48W (Typical)
23.8": 56.31W (Typical)
- **Power Input** 24 V_{DC} ± 20%
- **Watchdog Timer** 15-255 sec (system)
- **Weight (Net)** 12.1": 4.1kg (9.04lbs)
15": 5.8kg (12.79lbs)
17": 6.1kg (13.45lbs)
23.8": 9.3kg (20.5lbs)

System Hardware

- **CPU** Intel 8th Gen. Whiskey Lake
i3-8145UE 2.20 GHz Dual-core
i5-8365UE 1.60 GHz Quad-core
i7-8665UE 1.70 GHz Quad-core
- **Memory** Dual channel DDR4 SO-DIMM (Each channel supports up to 32G)
1 x 8G DDR4 SO-DIMM (Built-in)
- **LAN** 2 x 10/100/1000BASE-T (A ver.) or 2.5GbE (B ver.)

Features

- 8th Gen. Intel® Core™ i3- 8145UE dual-core/ i5-8365UE quad-core/ i7-8665UE quad-core processor with built-in 8 GB DDR4 SO-DIMM
- Dual channel memory slots support up to 64G in total
- Compact, fanless embedded system with aluminum alloy front bezel and chassis grounding protection
- True-flat touchscreen with 5-wire resistive touch control and IP66-rated front panel
- Support expansion via Full-size Mini PCIe and two M.2 slots (NVMe, 5G)
- Diverse system I/O and isolated digital I/O via iDoor technology
- Support fieldbus protocols/GPS/GPRS/Wi-Fi capabilities via iDoor technology
- Support TPM2.0 hardware security

- **Expansion Slot** 1 x Full-size mini PCIe
1 x SIM (M.2 B Key 4G/5G module)
- **Storage Slot** 1 x M.2 M key 2280 (SATA or NVMe PCIe x4)
1 x M.2 B key 2242 (SATA / PCIe)
3042, 3052 (5G)
1 x 2.5" SSD/HDD (SATA, Max. 7mm)
- **I/O** 2 x RS-232/422/485
1 x USB 2.0
4 x USB 3.2 (Gen 2)
1 x iDoor slot
1 x Displayport (Video output)
1 x Audio line out/ mic in

LCD Display

	TPC-312	TPC-315	TPC-317	TPC-324W
Display Type	XGA TFT LED LCD	XGA TFT LED LCD	SXGA TFT LED LCD	FHD TFT LED LCD
Display Size	12.1" (4:3)	15" (4:3)	17" (4:3)	23.8" (16:9)
Max. Resolution	1024 x 768	1024x768	1280 x 1024	1920 x 1080
Max Colour	16.2M	16.2M	16.7M	16.7M
Luminance cd/m²	300	300	300	350
Viewing Angle (H/V°)	178°/178°	176°/176°	160°/140°	178°/178°
Backlight Life	50,000 hrs	70,000hrs	50,000 hrs	30,000hrs
Contrast Ratio	1000:1	2000:1	800:1	1000:1

Touchscreen

- **Lifespan** 36 million touches at a single point
- **Light Transmission** Above 75%
- **Resolution** Linearity
- **Type** TPC-312/TPC-315/TPC-317: 5-wite resistive
TPC-324W: PCAP

Environment

- **Humidity** 10 ~ 95% RH @ 40°C, non-condensing
- **Ingress Protection** IP66-rated front panel
- **Operating Temperature** -10~55°C (14~131°F) (w/o air flow)
- **Storage Temperature** -20~70°C (-4~158°F)
- **Vibration Protection** With SSD: 1 Grms (5 ~ 500 Hz)
(Operating, random vibration)

Rear View

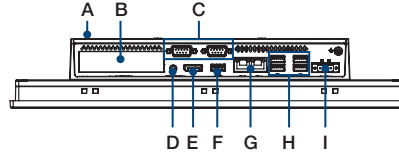

- A. Default HDD/SSD Bay
- B. iDoor slot
- C. RS-232/422/485
- D. Audio line out/ mic in
- E. Display Port
- F. USB 2.0
- G. LAN (Left: 1GbE, Right: 2.5GbE)
- H. USB 3.2 (Gen 2)
- I. Power Receptor

Dimensions

Unit: mm

TPC-312

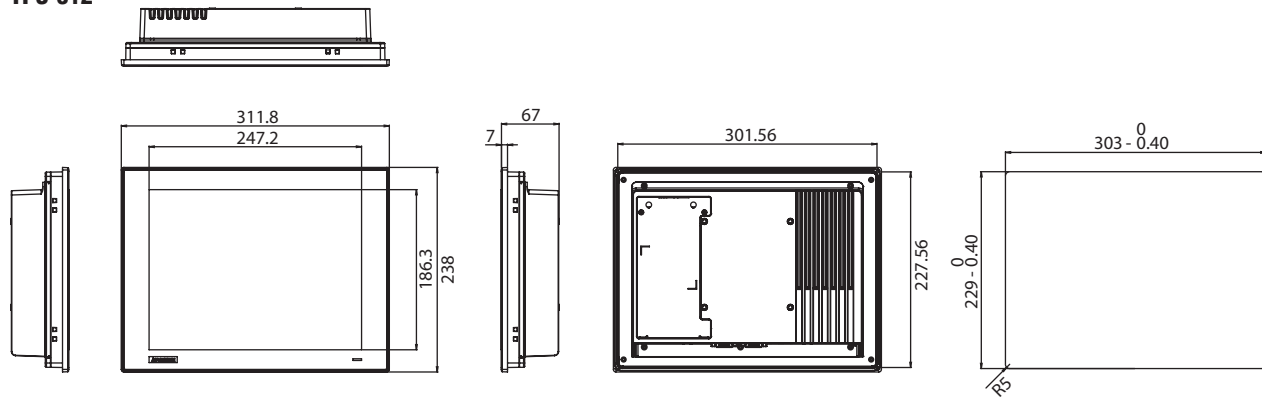

TPC-312 Panel Cutout Dimensions: 303 x 229 mm (11.93 x 9.02 in)

TPC-315

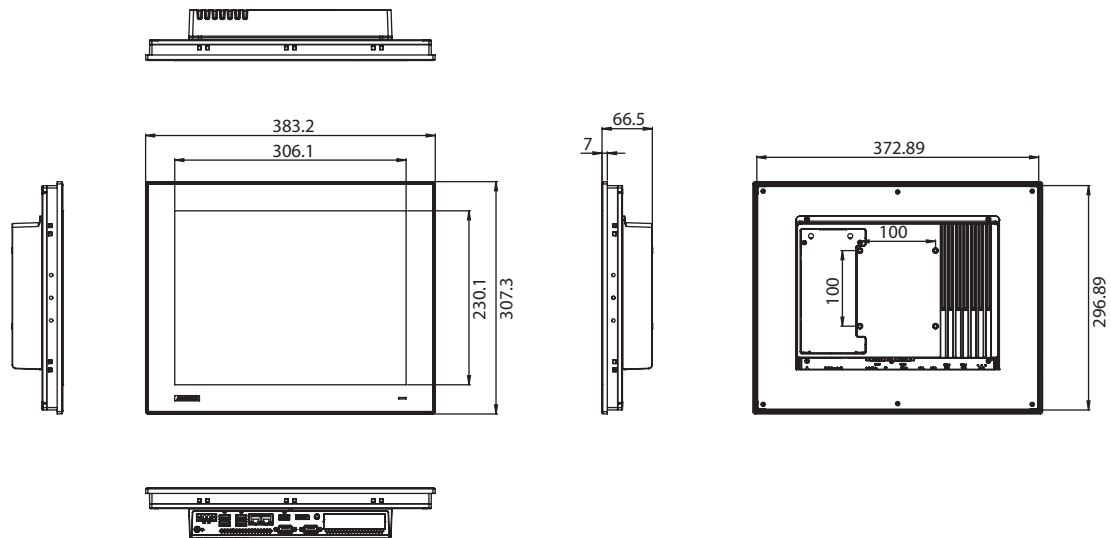

TPC-315 Panel Cutout Dimensions: 374.5 x 298.5 mm (14.74 x 11.75 in)

Dimensions

Unit: mm

TPC-317

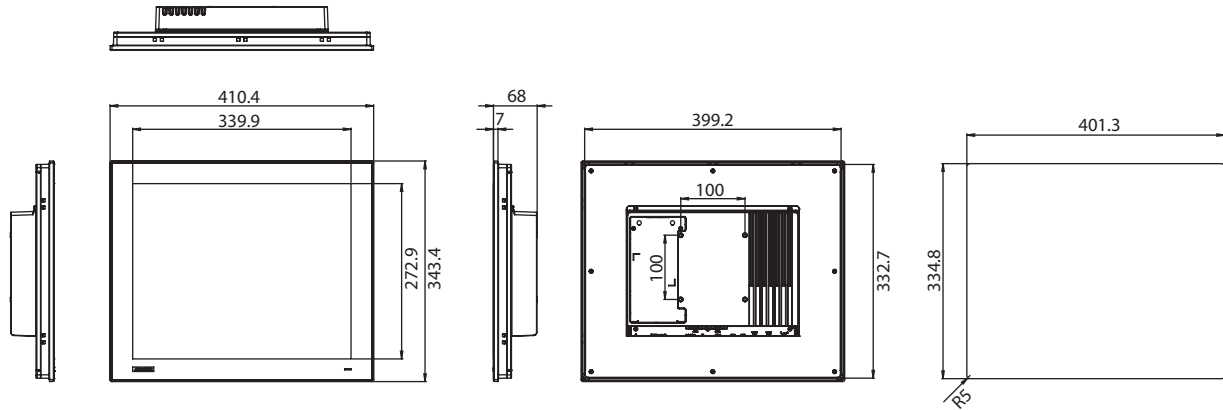

TPC-317 Panel Cutout Dimensions: 401.3 x 334.8 mm (15.80 x 13.18 in)

TPC-324W

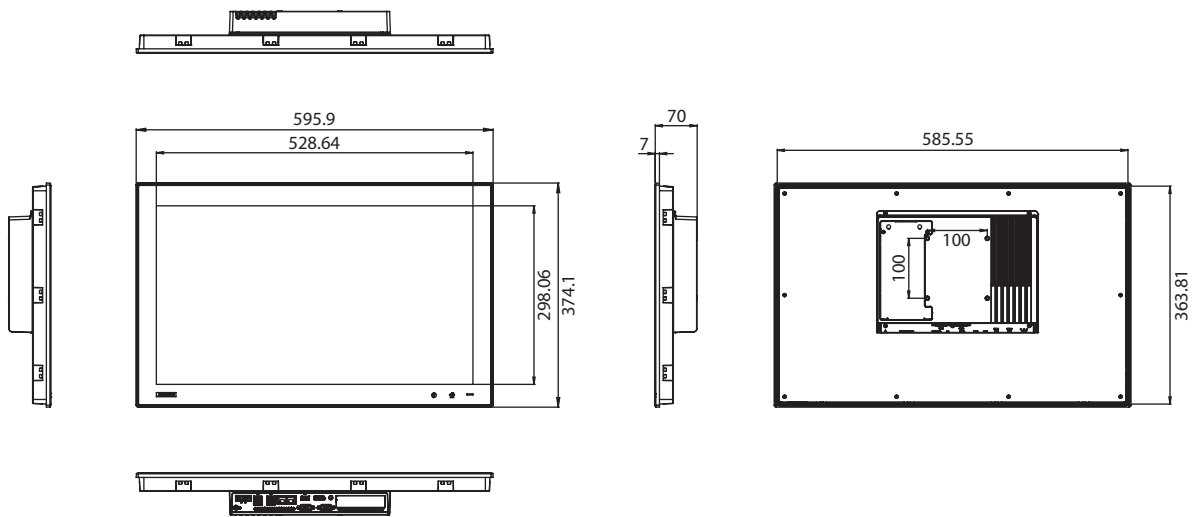

TPC-324W Panel Cutout Dimensions: 587 x 365.3 mm (23.11 x 14.38 in)

Ordering Information

- **TPC-312-R833A** 12.1" XGA Panel PC, Intel® Core™ i3-8145UE 2.20GHz Dual-core Processor, 8G DDR4 RAM
- **TPC-312-R853A** 12.1" XGA Panel PC, Intel® Core™ i5-8365UE 1.60GHz Quad-core Processor, 8G DDR4 RAM
- **TPC-312-R873A** 12.1" XGA Panel PC, Intel® Core™ i7-8665UE 1.70GHz Quad-core Processor, 8G DDR4 RAM
- **TPC-312-R833B** 12.1" XGA Panel PC, Intel® Core™ i3-8145UE 2.20GHz Dual-core Processor, 8G DDR4 RAM
- **TPC-312-R853B** 12.1" XGA Panel PC, Intel® Core™ i5-8365UE 1.60GHz Quad-core Processor, 8G DDR4 RAM
- **TPC-312-R873B** 12.1" XGA Panel PC, Intel® Core™ i7-8665UE 1.70GHz Quad-core Processor, 8G DDR4 RAM

- **TPC-315-R833A** 15" XGA Panel PC, Intel® Core™ i3-8145UE 2.20GHz Dual-core Processor, 8G DDR4 RAM
- **TPC-315-R853A** 15" XGA Panel PC, Intel® Core™ i5-8365UE 1.60GHz Quad-core Processor, 8G DDR4 RAM
- **TPC-315-R873A** 15" XGA Panel PC, Intel® Core™ i7-8665UE 1.70 GHz Quad-core Processor, 8G DDR4 RAM
- **TPC-315-R833B** 15" XGA Panel PC, Intel® Core™ i3-8145UE 2.20GHz Dual-core Processor, 8G DDR4 RAM
- **TPC-315-R853B** 15" XGA Panel PC, Intel® Core™ i5-8365UE 1.60GHz Quad-core Processor, 8G DDR4 RAM
- **TPC-315-R873B** 15" XGA Panel PC, Intel® Core™ i7-8665UE 1.70 GHz Quad-core Processor, 8G DDR4 RAM

- **TPC-317-R833A** 17" SXGA Panel PC, Intel® Core™ i3-8145UE 2.20GHz Dual-core Processor, 8G DDR4 RAM
- **TPC-317-R853A** 17" SXGA Panel PC, Intel® Core™ i5-8365UE 1.60GHz Quad-core Processor, 8G DDR4 RAM
- **TPC-317-R873A** 17" SXGA Panel PC, Intel® Core™ i7-8665UE 1.70GHz Quad-core Processor, 8G DDR4 RAM
- **TPC-317-R833B** 17" SXGA Panel PC, Intel® Core™ i3-8145UE 2.20GHz Dual-core Processor, 8G DDR4 RAM
- **TPC-317-R853B** 17" SXGA Panel PC, Intel® Core™ i5-8365UE 1.60GHz Quad-core Processor, 8G DDR4 RAM
- **TPC-317-R873B** 17" SXGA Panel PC, Intel® Core™ i7-8665UE 1.70GHz Quad-core Processor, 8G DDR4 RAM

- **TPC-324W-P833A** 23.8" FHD Panel PC, Intel® Core™ i3-8145UE 2.20GHz Dual-core Processor, 8G DDR4 RAM
- **TPC-324W-P853A** 23.8" FHD Panel PC, Intel® Core™ i5-8365UE 1.60GHz Quad-core Processor, 8G DDR4 RAM
- **TPC-324W-P873A** 23.8" FHD Panel PC, Intel® Core™ i7-8665UE 1.70GHz Quad-core Processor, 8G DDR4 RAM
- **TPC-324W-P833B** 23.8" FHD Panel PC, Intel® Core™ i3-8145UE 2.20GHz Dual-core Processor, 8G DDR4 RAM
- **TPC-324W-P853B** 23.8" FHD Panel PC, Intel® Core™ i5-8365UE 1.60GHz Quad-core Processor, 8G DDR4 RAM
- **TPC-324W-P873B** 23.8" FHD Panel PC, Intel® Core™ i7-8665UE 1.70GHz Quad-core Processor, 8G DDR4 RAM

Note:
 TPC-3xx-R8xxA version: Intel i219 + i210 LAN chipset (1GbE + 1GbE)
 TPC-3xx-R8xxB version: Intel i219 + i226 LAN chipset (1GbE + 2.5GbE)

Optional Accessories

- **96PSA-A120W24T2-3** 120W 24V_{DC} power supply
- **1702002600** Power cable (US) 1.8 M
- **1702002605** Power cable (EU) 1.8 M
- **1702031801** Power cable (UK) 1.8 M
- **1700000596-11** Power cable (China/Australia) 1.8 M

iDoor Modules

- **PCM-24D2R4-BE** Isolated RS-422/485, DB9 x 2, (USB type)
- **PCM-24D2R2-BE** Isolated RS-232, DB9 x 2, (USB type)
- **PCM-24R1TP-AE** 1-Port Gigabit Ethernet, Intel® 82574L, mPCIe, RJ45
- **PCM-27D24DI-AE** Digital I/O, 16 DI / 8 DO, Isolation, DB37 x 1
- **PCM-24S2WF-CE** 802.11 a/b/g/n/ac 2T2R w/BT4.1, Intel AC9260
- **PCM-26D2CA-AE** 2-Port Isolated CANBus mPCIe, CANOpen, DB9
- **PCM-23U1DG-CE** Internal locked USB Slot for USB Dongle, mPCIe
- **PCM-24R2GL-AE** 2 Port Giga LAN Intel i350 PCIe mini card
- **PCM-24S34G-ABE** TOBY-L200 LTE/HSPA+/GPRS, mPCIe, Ant, America (US)
- **PCM-24S34G-EBE** TOBY-L210 LTE/HSPA+/GPRS, mPCIe, Ant, EMEA/APAC (AU.EU)

Embedded OS

- **20704WX1HS0006** Img WIN10 LTSC V6.08 B018 TPC-300 High
- **20704WX1VS0006** Img WIN10 LTSC V6.08 B018 TPC-300 Value
- **20703LEB1S0091** Image AdvLinuxTu V2.0.6 for UNO/TPC series
- **Coming Soon** Android

Note : Compatible with both A and B versions

Application Software

WebAccess/SCADA	Advantech WebAccess/SCADA is a 100% browser-based IIoT software platform aimed at supervisory control and data acquisition (SCADA) operations. WebAccess/SCADA provides open interfaces that allow our customers and partners to develop unique IIoT applications for different vertical markets. In addition to supporting traditional SCADA functions, the platform features an HTML5-based user interface and intelligent dashboard to facilitate cross-platform, cross-browser data analysis. Moreover, WebAccess/SCADA not only offers built-in widgets, but is also equipped with an innovative Widget Builder that enables customers to build their own widgets.
WebAccess/HMI	Advantech WebAccess/HMI is human-machine interface (HMI) software based on Microsoft's Windows operating system. This software features excellent communication and monitoring capabilities, supports more than 350 PLC communication protocols, and offers a wide choice of screen design objects to satisfy diverse integrations of factory automation and HMI operation and monitoring requirements.

Please note: If some optional modules are offered with the system, additional system certificates may be required in certain regions/countries. Please contact Advantech for certificate compliance.