

Quick Start Guide

UNO-1110 Series 電腦

TI Cortex AM3505 DIN-rail PC
with 2 x LAN, 5 x COM, 4 x USB

ADVANTECH

Enabling an Intelligent Planet

Copyright

The documentation and the software included with this product are copyrighted 2013 by Advantech Co., Ltd. All rights are reserved. Advantech Co., Ltd. reserves the right to make improvements in the products described in this manual at any time without notice. No part of this manual may be reproduced, copied, translated or transmitted in any form or by any means without the prior written permission of Advantech Co., Ltd. Information provided in this manual is intended to be accurate and reliable. However, Advantech Co., Ltd. assumes no responsibility for its use, nor for any infringements of the rights of third parties, which may result from its use.

Acknowledgements

Intel and Pentium are trademarks of Intel Corporation.

Microsoft Windows and MS-DOS are registered trademarks of Microsoft Corp.

All other product names or trademarks are properties of their respective owners.

This manual applies to the below models which are abbreviated as UNO-1110 series products in this article.

UNO-1110-R11AE
UNO-1110SL-R11AE
UNO1110R11AE1401E-T
UNO1110R11AE1402E-T
UNO1110R11AE1403E-T
UNO1110R11AE1404E-T
UNO1110R11AE1405E-T
UNO1110R11AE1501E-T
UNO1110R11AE1502E-T
UNO1110R11AE1503E-T
UNO1110R11AE1504E-T
UNO1110R11AE1505E-T
UNO1110R11AE1601E-T
UNO1110R11AE1602E-T
UNO1110R11AE1603E-T
UNO1110R11AE1604E-T
UNO1110R11AE1605E-T

Product Warranty (2 years)

Advantech warrants to you, the original purchaser, that each of its products will be free from defects in materials and workmanship for two years from the date of purchase.

This warranty does not apply to any products which have been repaired or altered by persons other than repair personnel authorized by Advantech, or which have been subject to misuse, abuse, accident or improper installation. Advantech assumes no liability under the terms of this warranty as a consequence of such events.

Because of Advantech's high quality-control standards and rigorous testing, most of our customers never need to use our repair service. If an Advantech product is defective, it will be repaired or replaced at no charge during the warranty period. For out-of-warranty repairs, you will be billed according to the cost of replacement materials, service time and freight. Please consult your dealer for more details.

If you think you have a defective product, follow these steps:

1. Collect all the information about the problem encountered. (For example, CPU speed, Advantech products used, other hardware and software used, etc.) Note anything abnormal and list any onscreen messages you get when the problem occurs.
2. Call your dealer and describe the problem. Please have your manual, product, and any helpful information readily available.
3. If your product is diagnosed as defective, obtain an RMA (return merchandise authorization) number from your dealer. This allows us to process your return more quickly.
4. Carefully pack the defective product, a fully-completed Repair and Replacement Order Card and a photocopy proof of purchase date (such as your sales receipt) in a shippable container. A product returned without proof of the purchase date is not eligible for warranty service.
5. Write the RMA number visibly on the outside of the package and ship it prepaid to your dealer.

Declaration of Conformity

CE

This product has passed the CE test for environmental specifications when shielded cables are used for external wiring. We recommend the use of shielded cables. This kind of cable is available from Advantech. Please contact your local supplier for ordering information.

FCC Class A

Note: This equipment has been tested and found to comply with the limits for a Class A digital device, pursuant to part 15 of the FCC Rules. These limits are designed to provide reasonable protection against harmful interference when the equipment is operated in a commercial environment. This equipment generates, uses, and can radiate radio frequency energy and, if not installed and used in accordance with the instruction manual, may cause harmful interference to radio communications. Operation of this equipment in a residential area is likely to cause harmful interference in which case the user will be required to correct the interference at his own expense.

Technical Support and Assistance

1. Visit the Advantech web site at <http://support.advantech.com> where you can find the latest information about the product.
2. Contact your distributor, sales representative, or Advantech's customer service center for technical support if you need additional assistance. Please have the following information ready before you call:
 - Product name and serial number
 - Description of your peripheral attachments
 - Description of your software (operating system, version, application software, etc.)
 - A complete description of the problem
 - The exact wording of any error messages

BSMI ROHS

設備名稱：電腦 Equipment name		型號（型式）：UNO-1110（系列型號參見說明書） Type designation (Type)				
單元 Unit	限用物質及其化學符號 Restricted substances and its chemical symbols					
	鉛 Lead (Pb)	汞 Mercury (Hg)	鎘 Cadmium (Cd)	六價鉻 Hexavalent chromium (Cr ⁺⁶)	多溴聯苯 Polybrominated biphenyls (PBB)	多溴二苯醚 Polybrominated diphenyl ethers (PBDE)
電路板	—	○	○	○	○	○
固定組件（螺絲等）	—	○	○	○	○	○
內外殼	○	○	○	○	○	○
存取裝置 (SD)	—	○	○	○	○	○
<p>備考 1. “超出 0.1 wt %” 及 “超出 0.01 wt %” 係指限用物質之百分比含量超出百分比含量基準值。 Note 1. “Exceeding 0.1 wt %” and “exceeding 0.01 wt %” indicate that the percentage content of the restricted substance exceeds the reference percentage value of presence condition.</p> <p>備考 2. “○” 係指該項限用物質之百分比含量未超出百分比含量基準值。 Note 2. “○” indicates that the percentage content of the restricted substance does not exceed the percentage of reference value of presence.</p> <p>備考 3. “—” 係指該項限用物質為排除項目。 Note 3. The “—” indicates that the restricted substance corresponds to the exemption.</p>						

Safety Instructions

1. Read these safety instructions carefully.
2. Keep this User Manual for later reference.
3. Disconnect this equipment from any AC outlet before cleaning. Use a damp cloth. Do not use liquid or spray detergents for cleaning.
4. For plug-in equipment, the power outlet socket must be located near the equipment and must be easily accessible.
5. Keep this equipment away from humidity.
6. Put this equipment on a reliable surface during installation. Dropping it or letting it fall may cause damage.
7. The openings on the enclosure are for air convection. Protect the equipment from overheating. **DO NOT COVER THE OPENINGS.**
8. Make sure the voltage of the power source is correct before connecting the equipment to the power outlet.
9. Position the power cord so that people cannot step on it. Do not place anything over the power cord.
10. All cautions and warnings on the equipment should be noted.
11. If the equipment is not used for a long time, disconnect it from the power source to avoid damage by transient overvoltage.
12. Never pour any liquid into an opening. This may cause fire or electrical shock.
13. Never open the equipment. For safety reasons, the equipment should be opened only by qualified service personnel.
14. If one of the following situations arises, get the equipment checked by service personnel:
 15. The power cord or plug is damaged.
 16. Liquid has penetrated into the equipment.
 17. The equipment has been exposed to moisture.
 18. The equipment does not work well, or you cannot get it to work according to the user's manual.
 19. The equipment has been dropped and damaged.
 20. The equipment has obvious signs of breakage.
21. **DO NOT LEAVE THIS EQUIPMENT IN AN ENVIRONMENT WHERE THE STORAGE TEMPERATURE MAY GO BELOW -20° C (-4° F) OR ABOVE 60° C (140° F). THIS COULD DAMAGE THE EQUIPMENT. THE EQUIPMENT SHOULD BE IN A CONTROLLED ENVIRONMENT.**
22. **CAUTION: DANGER OF EXPLOSION IF BATTERY IS INCORRECTLY REPLACED. REPLACE ONLY WITH THE SAME OR EQUIVALENT TYPE RECOMMENDED BY THE MANUFACTURER, DISCARD USED BATTERIES ACCORDING TO THE MANUFACTURER'S INSTRUCTIONS.**
23. The sound pressure level at the operator's position according to IEC 704-1:1982 is no more than 70 dB (A).

DISCLAIMER: This set of instructions is given according to IEC 704-1. Advantech disclaims all responsibility for the accuracy of any statements contained herein.

安全指示

1. 請仔細閱讀此安全操作說明。
2. 請妥善保存此用戶手冊供日後參考。
3. 用濕抹布清洗設備前，請從插座拔下電源線。請不要使用液體或去汙噴霧劑清洗設備。
4. 對於使用電源線的設備，設備周圍必須有容易接觸到的電源插座。
5. 請不要在潮濕環境中使用設備。
6. 請在安裝前確保設備放置在可靠的平面上，意外跌落可能會導致設備損壞。
7. 設備外殼的開口是用於空氣對流，從而防止設備過熱。**請不要覆蓋這些開口。**
8. 當您連接設備到電源插座上前，請確認電源插座的電壓是否符合要求。
9. 請將電源線佈置在人們不易絆到的位置，並不要在電源線上覆蓋任何雜物。
10. 請注意設備上的所有警告和注意標語。
11. 如果長時間不使用設備，請將其同電源插座斷開，避免設備被超標的電壓波動損壞。
12. 請不要讓任何液體流入通風口，以免引起火災或者短路。
13. 請不要自行打開設備。為了確保您的安全，請由經過認證的工程師來打開設備。
14. 如遇下列情況，請由專業人員來維修：
 - 電源線或者插頭損壞；
 - 設備內部有液體流入；
 - 設備曾暴露在過於潮濕的環境中使用；
 - 設備無法正常工作，或您無法通過用戶手冊來使其正常工作；
 - 設備跌落或者損壞；
 - 設備有明顯的外觀破損。
15. 請不要把設備放置在超出我們建議的溫度範圍的環境，即不要低於 -20°C (-4°F) 或高於 60°C (140°F)，否則可能會損壞設備。
16. **注意：**如果電池放置不正確，將有爆炸的危險。因此，只可以使用製造商推薦的同一種或者同等型號的電池進行替換。請按照製造商的指示處理舊電池。
17. 本產品於國內裝置使用時，其電源僅限使用機架電源模組所提供直流電源輸入，不得使用交流電源及附加其他電源轉換裝置提供電源，其電源輸入電壓及電流請依說明書規定使用。
18. 根據 IEC 704 - 1:1982 規定，操作員所在位置音量不可高於 70 分貝。
19. **限制區域：**請勿將設備安裝於限制區域使用。
20. **免責聲明：**請安全訓示符合 IEC 704 - 1 要求。研華公司對其內容之準確性不承擔任何法律責任。

Safety Precaution - Static Electricity

Follow these simple precautions to protect yourself from harm and the products from damage.

- To avoid electrical shock, always disconnect the power from your PC chassis before you work on it. Don't touch any components on the CPU card or other cards while the PC is on.
- Disconnect power before making any configuration changes. The sudden rush of power as you connect a jumper or install a card may damage sensitive electronic components.

警告使用者：這是甲類資訊產品，在居住的環境中使用時，可能會造成射頻干擾，在這種情況下，使用者會被要求採取某些適當對策

Contents

Chapter 1	Overview.....	1
1.1	Introduction	2
1.2	Features	2
1.3	Hardware Specifications	2
1.4	Chassis Dimensions.....	4
	Figure 1.1 UNO-1110 Top View Dimensions.....	4
	Figure 1.2 UNO-1110 Side View Dimensions.....	4
Chapter 2	Installation.....	5
2.1	Overview	6
	Figure 2.1 UNO-1110 I/O Overview.....	6
	Table 2.1: UNO-1110 I/O Overview.....	7
2.2	LED Indicators.....	7
	Table 2.2: UNO-1110 LED Indicator Definitions.....	7
2.3	Network Connections	8
	Table 2.3: Ethernet RJ-45 Connector Pin Assigns	8
2.4	Serial Connections	8
2.4.1	Serial Mode and Terminator Resistor Selection	8
	Table 2.4: COM1 - COM4 Serial Port Setting.....	8
	Table 2.5: COM1 - COM4 Pin Assignments.....	9
	Figure 2.2 COM5 RS-485 Pin Assignments	9
2.5	Power Connections	10
	Figure 2.3 Power Pin Assignments	10
	Table 2.6: Power Pin Assignments.....	10
2.6	Digital Input/Output	10
	Figure 2.4 Digital I/O Pin Assignments	10
	Figure 2.5 Digital Input Connection (Dry Contact).....	10
	Figure 2.6 Digital Output Connections.....	11
2.7	Simulation DI.....	11
	Table 2.7: Simulation DI Setting	11
2.8	USB Connector	11
	Table 2.8: USB Connector Pin Assignments.....	11
2.9	VGA.....	12
	Table 2.9: VGA Adaptor Cable Pin Assignments	12
2.10	Reset Button	12
2.11	SD Slots	12
2.12	Debug Port.....	12
	Table 2.10: Debug Port Pin Assignments.....	12
2.13	Mounting	13
2.13.1	Wall Mounting	13
	Figure 2.7 Wallmount Kit Hole Dimension	13
2.13.2	DIN-rail Mounting	13
	Figure 2.8 Combine the DIN-rail Mounting Kit	13

Chapter 1

Overview

This chapter gives background information on the UNO-1110. It shows you the UNO-1110 overview and specifications.

Sections include:

- Introduction
- Features
- Hardware Specifications
- Safety Precautions
- Chassis Dimensions

1.1 Introduction

Advantech's UNO-1110 is a RISC-grade embedded platform that offers 2 LANs, 5 serial ports, 4 digital inputs and 2 digital outputs to fulfill I/O expansion needs. For data storage, UNO-1110 also provides a two SDs for OS and data storage, and supports Windows CE and Embedded Linux OS.

UNO-1110 operates from -10 ~ 70° C, its small size and light weight are suitable for all kinds of industrial environments. With these advantages, UNO-1110 is suitable as a communication gateway for converting communication protocols, and micro controllers.

UNO-1110 is a robust embedded ready platform that can shorten your development time and offer a rich networking interface to fulfill diverse application requirements.

1.2 Features

- TI Cortex A8 AM3505 600 MHz Processor
- 256 MB DDR2 on board
- 1 RS-485, 4 RS-232/422/485 serial ports
- Dual 10/100 Mbps Ethernet
- 2 SD slots for OS and data storage
- 4 channel digital inputs and 2 channel digital outputs
- Four simulation DI dip switch
- 4 channel user-defined programmable LEDs
- Ready platform for WinCE.NET and Embedded Linux
- Built-in Advantech DiagAnywhere agent for remote management and diagnosis. (Windows CE OS only)
- Fanless design for reliable system
- 10 ~ 30 V_{DC} Wide Dual Power Inputs with reserve power polarity protection
- Compact size and light weight
- -10 ~ 70° C wide range operation
- DIN-rail and wall mounting

1.3 Hardware Specifications

General

- **Certifications:** CE, FCC Class A, CCC, UL
- **Dimensions (W*H*D):** 50 x 154 x 127 mm
- **Enclosure:** Aluminium with solid mounting hardware
- **Power Input Range:** Dual 10 ~ 30 V_{DC} inputs with reserve power polarity
- **Mounting:** DIN35 rail, wall
- **Power Consumption:** 6 W (Typical)
- **Power Requirement:** 10 ~ 30 V_{DC} (e.g. + 24 V_{DC} @ 1 A) (Min. 24 W), AT
- **Weight:** 450g

System Hardware

- **CPU:** TI Cortex A8 AM3505 600 MHz
- **Memory:** 256 MB DDR2
- **VGA:** THS8136 controller, DB-15 VGA Connector (UNO-1110 only)
- **Indicators:** Power, Serial (Tx, Rx), SD, 4 x DI, 2 x DO, 4 programmable LEDs

- **Storage:** 2 SD slots
- **Others:** : Real Time Clock, Watch Dog Timer

System Software

- **OS:** WinCE .NET 6.0 / Embedded Linux
- **Remote Display:** DiagAnywhere Utility (Windows CE only)

Communication

- **Serial Ports:**
 - UNO-1110L: 2 x RS-232/422/485 (COM1 ~ COM2)
 - UNO-1110: 1 x RS-485, 4 x RS-232/422/485 (COM1 ~ COM5)
 - Automatic RS-485 data flow control
- **Serial Port Speed:**
 - RS-232: 300 ~ 115.2 kbps
 - RS-422/485: 300 ~ 115.2 kbps
- **LAN:** 2 x 10/100 Base-T RJ-45 ports

Digital I/O (UNO-1110 only)

- **Digital In:**
 - 4 Digital Input
 - Dry Contact:
 - Logic level 0 : Open
 - Logic level 1 : Close
- **Digital Out:**
 - 2 Digital Output
 - Open Collect to 30V
 - 200mA max Load
 - Power Dissipation 450mW

Environment

- **Operating Temperature:** -10 ~ 70° C (14° ~ 158° F)
- **Safety Cert. Temperature:** 60° C
- **Storage Temperature:** -20° ~ 80° C (-4° ~ 176° F)
- **Operating Humidity:** 20 ~ 95% (non-condensing)
- **Storage Humidity:** 0 ~ 95% (non-condensing)

1.4 Chassis Dimensions

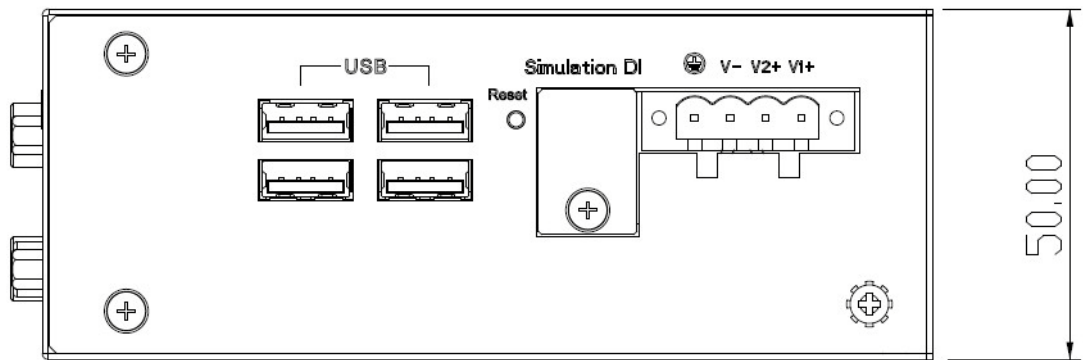

Figure 1.1 UNO-1110 Top View Dimensions

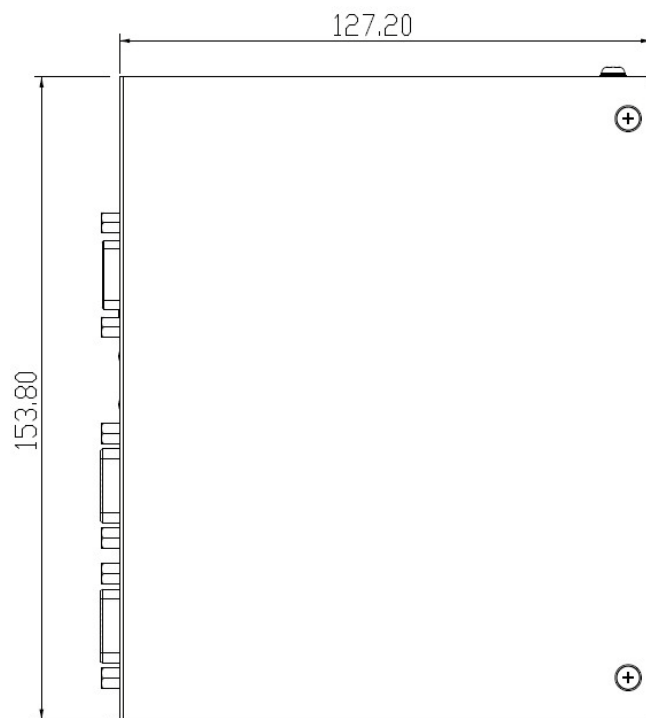

Figure 1.2 UNO-1110 Side View Dimensions

Chapter 2

Installation

In this chapter, you will be given an overview of the UNO-1110 hardware installation procedures.

Sections include:

- Overview
- LED
- Network Connections
- Serial Connections
- Power Connections
- Digital Input/Output
- CompactFlash
- Mounting

2.1 Overview

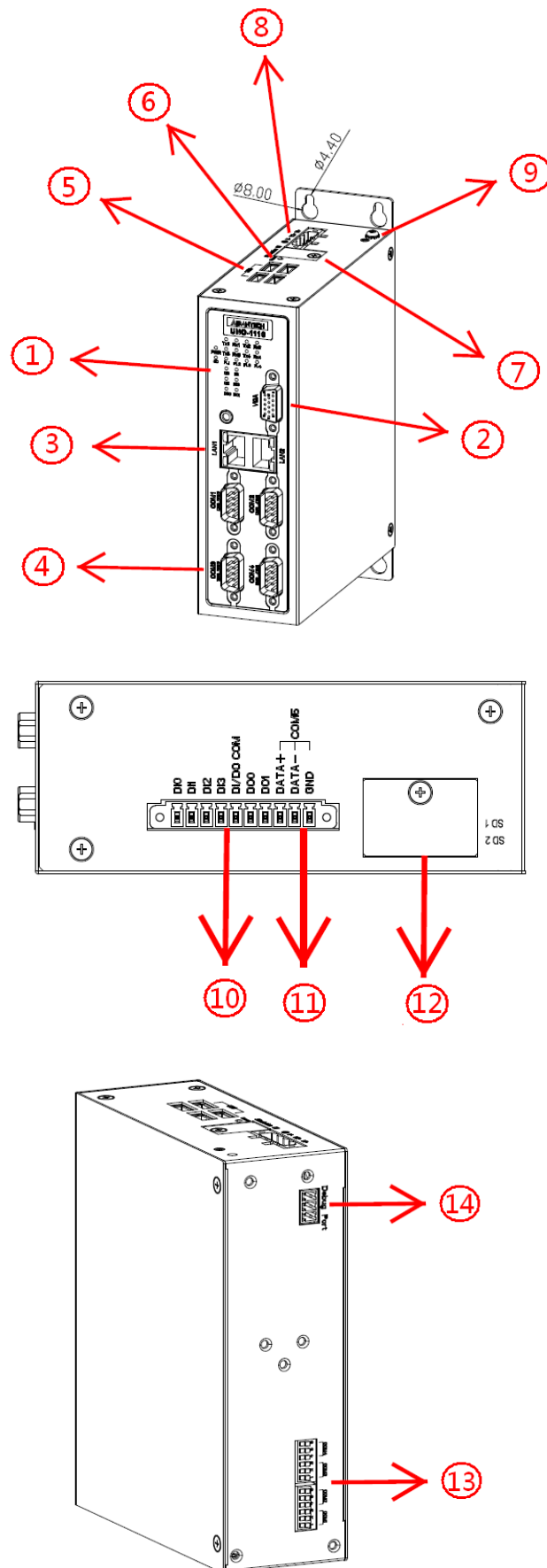

Figure 2.1 UNO-1110 I/O Overview

Table 2.1: UNO-1110 I/O Overview

Item	Description
1	LED Indicators
2	VGA
3	Ethernet Ports
4	Serial Ports
5	USB Ports
6	Reset Button
7	Simulation DI
8	Power Inputs
9	Chassis Grounding
10	Digital I/O
11	RS-485
12	SD Slots
13	COM Port Setting DIP Switch
14	Debug Port

2.2 LED Indicators

Several LEDs indicators display power, SD, Ethernet, serial, programmable LED and digital I/O status. They are located on the front panel of UNO-1110 and each of them has its own specific meaning, as shown in the table below.

Table 2.2: UNO-1110 LED Indicator Definitions

LED	Color	Status	Description
PWR	Red	On	System power is on
		Off	System power is off
SD	Green	Flash	Data is transmitting/receiving
Tx1 ~ Tx4	Yellow	Flash	Serial port COM1 - COM4 is transmitting data
Rx1 ~ Rx4	Green	Flash	Serial port COM1 - COM4 is receiving data
PL1 ~ PL4	Green	On	User Programmable LED on
		Off	User Programmable LED off
DI0 ~ DI3	Green/ Yellow	On	Input High
		Off	Input Low
DO0 ~ DO1	Green/ Yellow	On	Set False
		Off	Set True
LAN Link	Green	On	Connected to network
		Off	Not connected to network
		Flash	Data is transmitting / receiving
LAN Speed	Yellow	On	Link to 100 Mbps network
		Off	Link to 10 Mbps network

2.3 Network Connections

The UNO-1110 is equipped with a SMSC LAN8720AI (LAN1) & a DAVICOM DM9000BI (LAN2) Ethernet LAN controller that provide standard RJ-45 jack with 10/100 Mbps. LED indicators on the front side to show its Link (Green LED) and Active (Yellow LED) status.

Table 2.3: Ethernet RJ-45 Connector Pin Assigns

Pin	10/100Base-T Signal Name
1	XMT+
2	XMT-
3	RCV+
4	NC
5	NC
6	RCV-
7	NC
8	NC

2.4 Serial Connections

2.4.1 Serial Mode and Terminator Resistor Selection

UNO-1110 provides 5 serial COM ports, COM1 - COM4 provide RS-232/422/485, and COM5 provides RS-485. The default settings of COM1 - COM4 are RS-232. Users can change COM1 - COM4 types to RS-422 or RS-485 by SW3/SW4 DIP switch selection located on rear side of UNO-1110. UNO-1110L supports COM1 and COM2 ports only.

You can enable RS-422/485 terminator resistors if necessary to match impedance. Especially in fields with electric noise, enabling terminal resistors is helpful to stabilize communications. Make sure that both sides of the RS-422 or RS-485 communication ports are installed on BUS.

Table 2.4: COM1 - COM4 Serial Port Setting









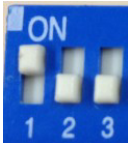

COM1/COM3 DIP Switch	COM2/COM4 DIP Switch	Serial Mode	Receiver Termination Mode
		N/A	N/A
		RS-232 Standard Mode	N/A
		RS-422 Master	120 Ohms Terminator Resistor

Table 2.4: COM1 - COM4 Serial Port Setting

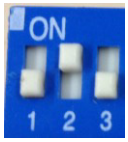
		RS-422 Master	No Termination
		RS-485 Auto Flow Mode	120 Ohms Terminator Resistor
		RS-485 Auto Flow Mode	No Termination

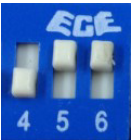
Refer to the figure and table below for COM1 - COM4 pin assignment.

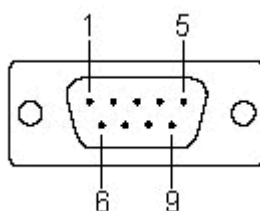

Table 2.5: COM1 - COM4 Pin Assignments

Pin	RS-232	RS-422	RS-485
1	DCD	TxD-	Data-
2	RxD	TxD+	Data+
3	TxD	RxD+	-
4	DTR	RxD-	-
5	GND	GND	GND
6	DSR	-	-
7	RTS	-	-
8	CTS	-	-
9	RI	-	-

Refer to figure below for COM5.

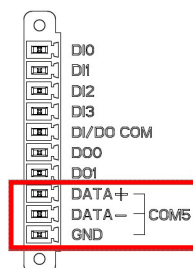

Figure 2.2 COM5 RS-485 Pin Assignments

2.5 Power Connections

UNO-1110 supports +10 ~ 30 V_{DC} power inputs. A detailed power pin description is shown below.

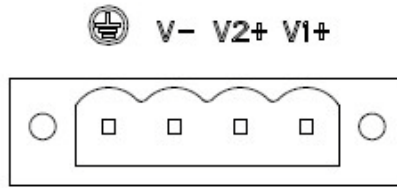



Figure 2.3 Power Pin Assignments

Table 2.6: Power Pin Assignments

Pin	Description
V1+	+ VDC 1
V2+	+ VDC 2
V-	PGND
	Chassis Grounding

2.6 Digital Input/Output

There are four digital inputs and two digital outputs on UNO-1110.

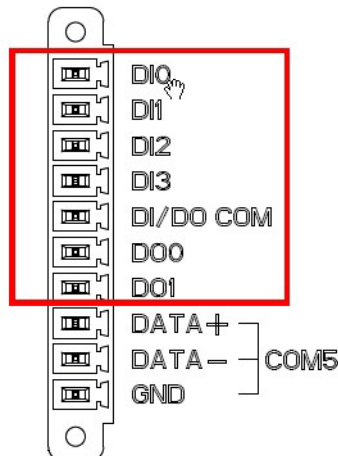

Figure 2.4 Digital I/O Pin Assignments

Figure 2.5 shows the digital input connection.

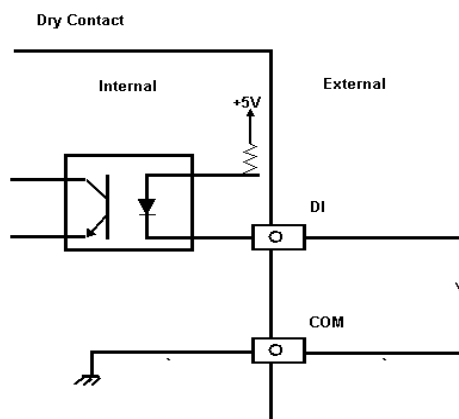

Figure 2.5 Digital Input Connection (Dry Contact)

UNO-1110 also provides two digital outputs connection, please refer below figure shows how to connect digital output function. (The default DO status is high)

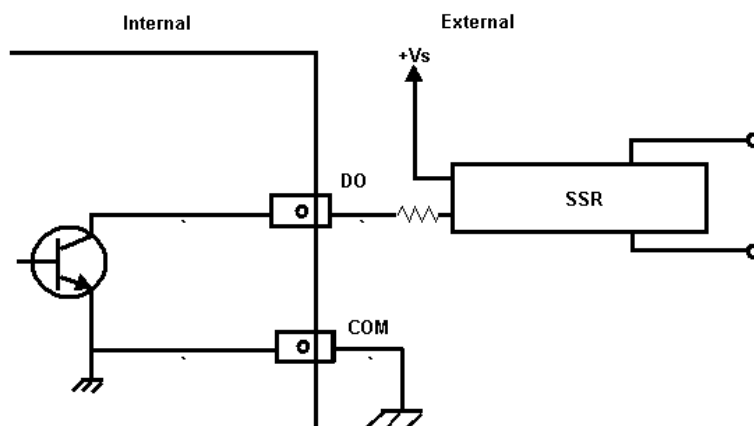

Figure 2.6 Digital Output Connections

2.7 Simulation DI

UNO-1110 provides four simulation DI lines via DIP switch setting located on the top side of UNO-1110.

Simulation DI is user-friendly design for users to setup different system parameters / configuration according to DIP switch setting.

Table 2.7: Simulation DI Setting

DIP Switch	Logic
ON	0
OFF	1

2.8 USB Connector

The USB interface supports Plug and Play, which enables you to connect or disconnect a device whenever you want, without turning off the computer.

The UNO-1110 provides four connectors of USB interfaces, which gives complete Plug & Play and hot swapping for up to 127 external devices. The USB interface complies with USB EHCI, Rev. 2.0 compliant.

Note! If use high power USB device, it is better plug-in device before system turn-ON.



Table 2.8: USB Connector Pin Assignments

Pin	Signal Name	Cable Color
1	VCC	Red
2	DATA-	White
3	DATA+	Green
4	GND	Black

2.9 VGA

The UNO-1110 provides a VGA 16bit converter (THS8136) for a high resolution VGA interface. CRT Mode: 1024 x 768 @ 60Hz, 800 x 600 @ 60Hz, 640 x 480 @ 60Hz.

Table 2.9: VGA Adaptor Cable Pin Assignments

Pin	Signal Name	Pin	Signal Name
1	RED	9	EDID Power
2	GREEN	10	GND
3	BLUE	11	NC
4	NC	12	NC
5	GND	13	H-SYNC
6	GND	14	V-SYNC
7	GND	15	NC
8	GND		

2.10 Reset Button

Press the "Reset" button to activate the reset function.

2.11 SD Slots

UNO-1110 provides two SD slots for OS and data storage.

It is full compliance with SD command / response sets as defined in the SD Memory Card Specifications, V2.0 including high capacity SDHC cards up to 32GB.

The procedure for installing a SD card into the UNO-1110 is detailed below, please follow these steps carefully

1. Make sure system power is off.
2. Remove the power cord.
3. Remove SD slot protection cover on the bottom side of UNO-1110.
4. Plug a SD card into a SD card slot.

2.12 Debug Port

Debug port is reserved for engineers to proceed hardware debug and / or console access.

Debug Port

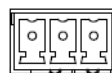

3 2 1

Table 2.10: Debug Port Pin Assignments

Pin	Description
1	TxD
2	RxD
3	GND

2.13 Mounting

UNO-1110 supports two different mounting methods: Wall & DIN-rail.

2.13.1 Wall Mounting

UNO-1110 can be wall mounted by using appropriate screws according to hole dimensions shown below.

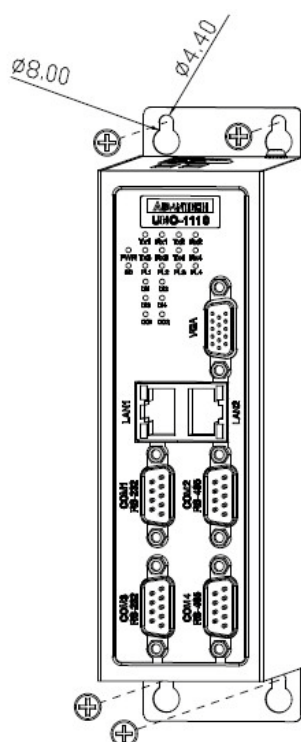

Figure 2.7 Wallmount Kit Hole Dimension

2.13.2 DIN-rail Mounting

UNO-1110 can be DIN-rail mounted by using the included DIN-rail mounting kit.

First, use the screws included in the package to combine the UNO-1110 and DIN-rail mounting kit.

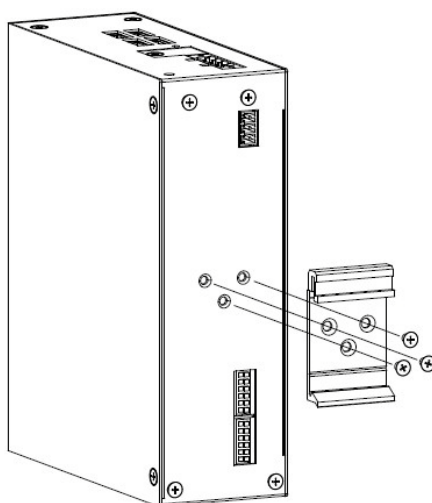

Figure 2.8 Combine the DIN-rail Mounting Kit

Hang the UNO-1110 to the DIN-rail with a suitable angle of inclination.

www.advantech.com

Please verify specifications before quoting. This guide is intended for reference purposes only.

All product specifications are subject to change without notice.

No part of this publication may be reproduced in any form or by any means, electronic, photocopying, recording or otherwise, without prior written permission of the publisher.

All brand and product names are trademarks or registered trademarks of their respective companies.

© Advantech Co., Ltd. 2016