

Dimensions

Unit: mm

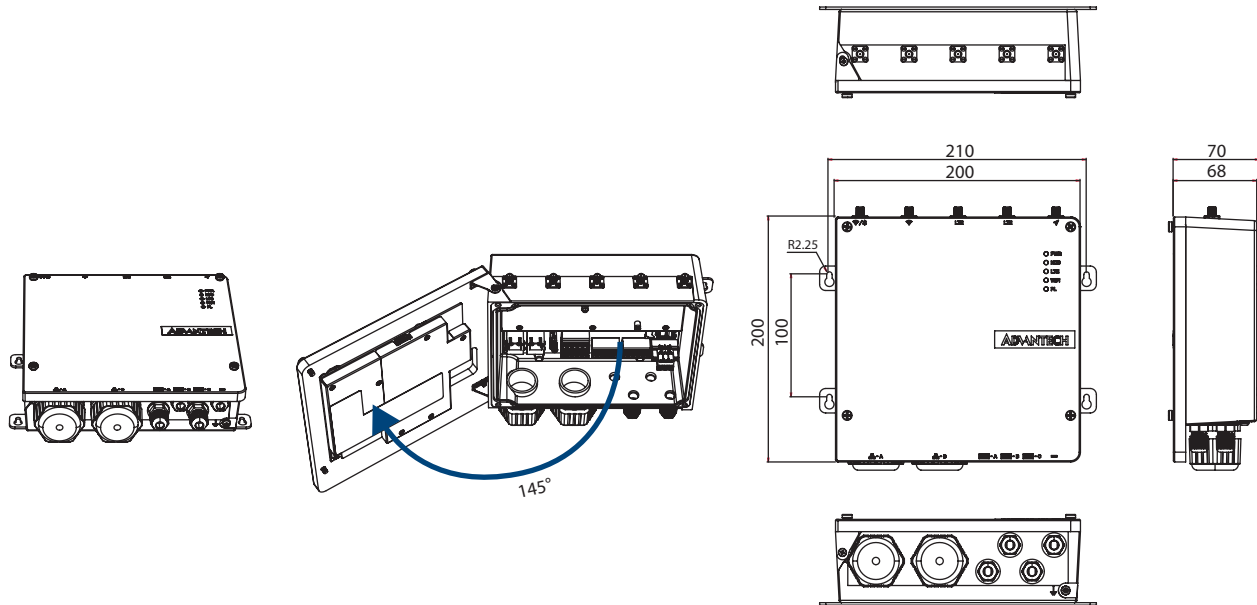

Ordering Information

- **UNO-430-E1A** Intel® Atom™ E3950, 2 GHz, processor with 8GB DDR3L memory, 2 x GbE, 3 x COM, TPM 2.0, and M32/M12 waterproof cable gland

Embedded OS

- **20703WX9ES0035** WIN10 IoT Enterprise LTSC x64 v6.05 B037
- **20703LEB1S0101** Image AdvLinuxTu V2.1.0 for UNO/TPC series

Optional Accessories

M.2 2242 SATA SSD

- **SQF-SM4M2-64G-SBE** 64GB M.2 SSD, SQFlash 640, SATA III (-40 ~ 85 °C/-40 ~ 185 °F)
- **SQF-SM4M2-128G-SBE** 128GB M.2 SSD, SQFlash 640, SATA III (-40 ~ 85 °C/-40 ~ 185 °F)
- **SQF-SM4M2-256G-SBE** 256GB M.2 SSD, SQFlash 640, SATA III (-40 ~ 85 °C/-40 ~ 185 °F)

Wi-Fi

- **EWM-W195M201E** M.2 2230 Wi-Fi module (802.11 a/b/g/n/ac with BT4.2) (-40 ~ 85 °C/-40 ~ 185 °F) with CE-RED compliance
- **1751000018-01** Dipole antenna (2.4 + 5GHz) SMA/M-R

LTE/GPS

- **968AD00426** Sierra EM7565 LTE Cat-12 M.2 module (global band)
- **968AD00590** Quectel EM06-E LTE Cat-6 M.2 module (EMEA/Brazil/APAC) with CE-RED compliance
- **1751000017-01** LTE dipole antenna (3.2/4.4dBi) SMA/M
- **1751000044-01** GPS antenna (3dBi) SMA/M

AT&T/Verizon-certified LTE kit for North America

- **C-PCM-24S24G-430-1** MultiTech LTE Cat.4 modem, antennas, for UNO-430-E1A

*For GPS Function, please order additional SMA cable and Antenna:

- **1751000035** Cable Ant. SMA/F-BH MHF1/113 BLK L200mm
- **1751000044-01** GPS antenna (3dBi) SMA/M

IP65-Rated Power Supply

- **XUNO-HEP-100-24A** 100W 90 ~ 305V_{ac} power supply (-55 ~ 70 °C/-67 ~ 158 °F)